

# Radio-Electronics

TELEVISION • SERVICING • HIGH FIDELITY

HUGO GERNSBACK, Editor-in-chief

## BUILD A LOW-NOISE NUVISTOR TV BOOSTER

Two little nuvistors make a booster with a signal-to-noise ratio that could formerly be equaled only with very expensive tubes.

## MORE NEW FM STEREO MULTIPLEX SCHEMATICS

Most of the manufacturers have modified or changed their original circuits. See the latest ones, with explanations of how they work.

## ALL-MASTER INTERCOM IS EASILY BUILT

Using only one 4-transistor amplifier, this unit goes into action instantly; is economical to operate. Any number of stations can be used.

## THE OSCILLOSCOPE —ITS USES IN INDUSTRY

The general as well as the industrial electronics technician will find this article with its photos of waveforms useful and interesting. Describes a large number of techniques and tests.

**Gold Makes Better Resistors**

See Page 4

50c

W P SMITH 9-64  
4934 CLAXTON  
LOUIS 20 MO

**BEST FOR YOU—  
IT'S MOST VERSATILE**

**TRIPLET**

**MODEL 850  
ELECTRONIC  
VOLT-OHMMETER**

**USES UNLIMITED:**

Field Engineers • Application Engineers • Electrical Radios, TV, and Appliance Servicemen • Electrical Contractors • Factory Maintenance Men • Industrial Electronic Maintenance Technicians • Home Owners Hobbyists

**MODEL 850 \$79.50**

**FACTS MAKE FEATURES:**

- 1** Long 7" easy-to-read scale.
- 2** .5 D.C. volt range for transistor circuits.
- 3** HIGH STABILITY. Meter connected in cathode circuit of 12 AU7.

High Input Impedance (11 MEGOHMS) and wide Frequency Ranges give this extremely versatile Electronic Volt-Ohmmeter considerable advantage in the measurement of DC voltages, AC RMS and Peak-to-Peak voltages. It measures directly the Peak-to-Peak values of high-frequency complex wave forms and RMS values of sine waves on separate scales. Exclusive Triplett BAR-RING instrument is fully self-shielded; high flux magnet and spring-backed jewels for ruggedness. Wired circuit.

**ADDED PROTECTION.** Meter is shorted out in OFF position for greater damping, meter safety during transit, electrically protected against accidental overload. ZERO CENTER mark for FM discriminator alignment, plus other galvanometer measurements.

New pencil thin test probe used for all functions: DC, AC, and ohms. No need to change cables. Beautifully styled case for professional appearance and functional utility, 7 1/8" x 6 7/16" x 3 3/4".

Carrying handle can be used as a tester stand to place the tester at 25° angle for ease in reading.

Frequencies to 250 MC may be measured with auxiliary Diode. Probe, \$7.50 extra. DC voltages to 50 KV may be measured with auxiliary High Voltage Probe. \$20.50 extra.

**TRIPLET ELECTRICAL INSTRUMENT COMPANY, BLUFFTON, OHIO**

**CARRYING CASE**

Case 859—OP—Black leather  
Padded Carrying Case \$19.50 Net



**RANGES**

8 DC VOLTS RANGES	0-.5-1.5-5-15-50-150-500-1500
7 AC RMS VOLTS RANGES	0-1.5-5-15-50-150-500-1500
7 PEAK-TO-PEAK VOLTS RANGES	0-4-14-40-140-400-1400-4000
7 RESISTANCE RANGES	0-1000-10,000-100,000 OHMS; 1-10-100-1000 MEGOHMS.

**FREQUENCY RANGE** 15 CPS to 3MC; (Up to 250 MC with accessory diode probe available extra.)

**INPUT IMPEDANCE** DC Volts 11 Megohms;  
AC Volts minimum of .83 Megohms.



630

630-A

630-PL

630-APL

630-NA

630-T

631

310

666-HH

800

666-R

**THE WORLD'S MOST COMPLETE LINE OF V-O-Ms, AVAILABLE FROM YOUR TRIPLET DISTRIBUTOR'S STOCK**

**RUSH ME THE FACTS**

**On The World's Only Turn-Table**

To: Empire Scientific Corp.  
1075 Stewart Ave., Garden City, N.Y.

Name \_\_\_\_\_

Address \_\_\_\_\_

City \_\_\_\_\_ State \_\_\_\_\_

**...world's  
most perfect  
record playback  
system**

**Always playing, always tracking . . .** right side up or upside down. The sensational Empire Troubador demonstration of a continuously rotating turntable amazes the crowds at hi fi shows across the country.

Right down the line, America's music magazines have been using some well-turned phrases in editorial evaluations of the Troubador. **High Fidelity**, turning to the United States Testing Company for its report, found the Troubador to be a "precision-engineered product of the highest quality . . . wow, flutter and rumble completely inaudible." **Audio** said: "precise performance . . . an excellent buy . . . no acoustic feedback." **American Record Guide**: ". . . these (performance) figures have not been bettered by any turntable I have tested."

If you think you've never heard the Troubador, think again. More stereo FM radio stations across the country use the Troubador than any other record playback system. As Don Hambly, station manager of KRE AM/FM said: "The Empire tables have all the basic requirements of design and simplicity of operation and maintenance."

The Empire Scientific Corp. turns out a limited number of Troubadors for the music lover who appreciates the very finest in record playback. Complete price \$200.

## empire troubadour

# ...WORLD'S ONLY TURN-TABLE!



**empire**  
SCIENTIFIC CORP. 1075 STEWART AVE.  
GARDEN CITY, N.Y.

# Radio-Electronics

JUNE 1962  
VOL. XXXIII No. 6

Formerly RADIO CRAFT — Incorporating SHORT WAVE CRAFT — TELEVISION NEWS — RADIO & TELEVISION\*

## editorial

Hugo Gernsback 31 Earth Signals on the Moon

## audio—high fidelity—stereo

Earl E. Snader 35 What About the Bias Oscillator?  
*First of a series on the heartland of tape recording*

Robert D. Hochberg 50 7-Station Intercom Uses 1 Master  
*System has transistor amplifier and binary switching for flexibility*

Norman H. Crowhurst 53 More Circuits for FM Stereo  
*Eico, Fisher, Heath and Paco*

## radio

Stanley Leinwoll 52 SW Propagation Forecast  
*May 15-June 15*

64 Single-Sideband Techniques Improve Shortwave Listening

E. L. Safford, Jr. 80 Midget 4-Channel CB R/C Receiver  
*4-transistor package circuit makes it small*

## test instruments

I. Queen 70 Expanded-Scale Voltmeter  
*Checks nickel-cadmium batteries accurately*

Wayne Lemons 74 Two new tools for transistor servicing  
*Equipment report: Heathkit IM-30 and B&K model 960*

## electronics

Eric Leslie 47 Automation Makes Golden Resistors (Cover Feature)

59 What's Your EQ?  
*Answers to May puzzles on page 70*

John A. Comstock 84 Soldering Shortcuts  
*A page of pictorial hints*

## industrial electronics

Alex M. Schotz 32 Check Auto Ignition with an Ohm-Dwell Tachometer  
*Transistorized automotive test instrument you can build*

Robert G. Middleton 44 Unusual Oscilloscope Techniques  
*Industrial methods applicable to TV service*

Dellroye D. Darling 48 Induction Heating Turns the Trick  
*Heating the outside without warming the inside*

## television

John R. Lange 38 Nuvistors Cut Noise in VHF TV Booster  
*Cut down on the snow. Try this do-it-yourself unit*

Larry Steckler 41 Tube Layouts in TV Sets—Motorola 1961-1962

Mike Wayne 56 Jumping to Conclusions  
*The jumper wire in TV service*

W. E. Parker 60 TV Camera You Can Build—Part II  
*Circuit operation and coil-winding details*

Jack Darr 66 Service Clinic  
*Vertical bending at top of picture*

72 RATAN—Harbor TV Radar  
*Makes any uhf TV set a radar receiver*

## what's new

43 Pictorial reports of new developments

## the departments

102 Corrections  
22 Correspondence  
102 New Books

92 New Literature  
97 New Patents  
87 New Products

95 New Tubes & Semiconductors  
6 News Briefs  
105 Noteworthy Circuits  
98 Technicians' News

85 Technotes  
100 Try This One  
99 50 Years Ago

Over 50 Years  
of Electronic Publishing

EDITOR-IN-CHIEF AND PUBLISHER  
*Hugo Gernsback*

EDITOR  
*M. Harvey Gernsback*

MANAGING EDITOR  
*Fred Shunaman*

TECHNICAL EDITOR  
*Robert F. Scott, W2PWG*

ASSOCIATE EDITOR  
*Larry Steckler*

EDITORIAL ASSOCIATE  
*I. Queen*

SERVICE EDITOR  
*Jack Darr*

TECH. ILLUSTRATION DIRECTOR  
*Wm. Lyon McLaughlin*

ART ASSOCIATE  
*Fred Neinast*

DIRECTOR OF PRODUCTION  
*Elizabeth Stalcup*

DIRECTOR, ADVERTISING SALES  
*Lee Robinson*

EASTERN SALES MANAGER  
*John J. Lamson*

CIRCULATION MANAGER  
*G. Aliquo*

DIRECTOR, NEWSSTAND SALES  
*Joseph L. Bund*



Average Paid Circulation  
Over 160,000

## —on the cover—

Story on page 47

Precision resistors are made with greater accuracy and reliability in a completely automated plant. Cover shows gold ends being sputtered on resistors in a vacuum atmosphere.

Color original by Western Electric Co., Winston-Salem, N.C.

## Gernsback Publications, Inc.

EXECUTIVE, EDITORIAL, ADVERTISING OFFICES

154 W. 14 St., New York 11, N.Y.  
Telephone AL 5-7755

CHAIRMAN OF THE BOARD  
*Hugo Gernsback*

PRESIDENT  
*M. Harvey Gernsback*

SECRETARY  
*G. Aliquo*



Radio-Electronics is indexed in  
Applied Science & Technology Index  
(Formerly Industrial Arts Index)

\*Trademark registered U. S. Pat. Office

# GET YOUR ELECTRONICS-TV-RADIO HOME TRAINING FROM N.T.S. RESIDENT SCHOOL

**BREAK THROUGH TO HIGHER PAY, GREATER JOB SECURITY**

**START NOW!** Break through the Earning Barrier that stops "half-trained" men. N.T.S. "All-Phase" Training prepares you . . . at home in spare time . . . for a high-paying CAREER as a **MASTER TECHNICIAN** in Electronics — TV — Radio. One Master Course at One Low Tuition trains you for unlimited opportunities in All Phases: Servicing, Communications, Preparation for F.C.C. License, Broadcasting, Manufacturing, Automation, Radar and Micro-Waves, Missile and Rocket Projects.

**A MORE REWARDING JOB . . .** a secure future . . . a richer, fuller life can be yours! As an N.T.S.

**MASTER TECHNICIAN** you can go straight to the top in industry . . . or open your own profitable business.

**Over 1 City Block of Modern School Facilities, Laboratories and Shops Housing Over 1,000 Students.**

**50,000 Graduates — all over the World — since 1905**

**BETTER . . . MORE COMPLETE . . . LOWER COST . . . WITH NATIONAL SCHOOLS' SHOP-METHOD HOME TRAINING!**

**BETTER . . .** Training that is proved and tested in N.T.S. Resident School shops and laboratories, by a School that is the **OLDEST** and **LARGEST** of its kind in the world.

**MORE COMPLETE . . .** You learn **ALL PHASES** OF Television — Radio — Electronics.

**LOWER COST . . .** Other schools make several courses out of the material in our **ONE MASTER COURSE . . .** and you pay more for less training than you get in our course at **ONE LOW TUITION!**

**NATIONAL TECHNICAL SCHOOLS**  
WORLD-WIDE TRAINING SINCE 1905

**THE SCHOOL BEHIND YOUR HOME-STUDY TRAINING**

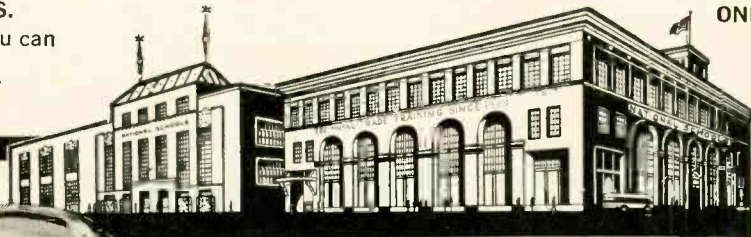

In these modern School Headquarters your Home Training is:  
Classroom-Developed, Lab-Studio Planned, Shop-Tested, Industry-Approved, Home Study-Designed.

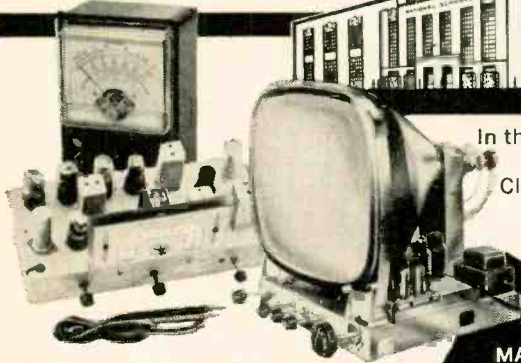

**TRAIN AT HOME IN YOUR SPARE TIME . . . AT YOUR OWN PACE!**

## 19 BIG KITS YOURS TO KEEP

- Friendly Instruction and Guidance
- Graduate Advisory Service
- Unlimited Consultation
- Diploma Recognized by Industry
- **EVERYTHING YOU NEED FOR SUCCESS**

## N.T.S. IS NOT JUST A MAILING ADDRESS ON A COUPON

N.T.S. is a real school . . . a world famous training center since 1905. Thousands of men from all over the world come to train in our shops, labs, studios and classrooms.

You learn quickly and easily the N.T.S. Shop-Tested way. You get lessons, manuals, job projects, personal consultation from instructors as you progress. You build a Short-Wave, Long-Wave Superhet Receiver plus a large screen TV set from the ground up with parts we send you at no additional cost. You also get a Professional Multitester for your practical job projects. The Multitester will become one of your most valuable instruments in spare time work while training, and afterwards, too. Many students pay for their entire tuition with spare time work. You can, too . . . we show you how.

**SEND FOR INFORMATION NOW . . . TODAY!**  
**IT COSTS YOU NOTHING TO INVESTIGATE**

After you graduate you can open your own TV-Radio repair business or go into high paying jobs like these: Communications Technicians, Hi-Fi, Stereo and Sound Recording Specialists, TV-Radio Broadcasting Technician, Technician in Computers & Missiles, Electronics Field Technician, Specialist in Micro-Waves and Servomechanisms, Expert Trouble Shooter, All-Phase Master Technician, TV-Radio Sales, Service and Repair.

**RESIDENT TRAINING AT LOS ANGELES**  
If you wish to take your Electronics-TV-Radio training in our famous Resident School in Los Angeles — the oldest and largest school of its kind in the world — write for special Resident School catalog and information, or check special box in coupon.

**MAIL COUPON NOW FOR FREE BOOK & ACTUAL LESSON**

No obligation.  
No salesman will call.



**NATIONAL TECHNICAL SCHOOLS**  
WORLD-WIDE TRAINING SINCE 1905

Mail Now To  
National Technical Schools, Dept. RG-62  
4030 S. Figueroa St., Los Angeles 37, Calif.  
Please rush **FREE** Electronics-TV-Radio "Opportunity" Book and Actual Lesson.

Name \_\_\_\_\_ Age \_\_\_\_\_  
Address \_\_\_\_\_  
City \_\_\_\_\_ Zone \_\_\_\_\_ State \_\_\_\_\_

Check here if interested ONLY in Resident Training at Los Angeles.  
**VETERANS:** Give date of discharge \_\_\_\_\_



ACCREDITED MEMBER

**NATIONAL TECHNICAL SCHOOLS**  
WORLD-WIDE TRAINING SINCE 1905

4000 50. FIGUEROA ST., LOS ANGELES 37, CALIF., U.S.A.

# News Briefs

## Earth Station

The term is no longer science fiction—you can visit one in Andover, Me. Constructed by Bell Telephone, it is the US link in a worldwide communications system making use of a series of Telstar repeater satellites. Telephone and TV messages will be exchanged between the site and the satellite in orbit. The satellite will receive, amplify and retransmit the signal to similar stations in other parts of the world. Eventually, a total of 20-40 satellites, in orbit, will be needed to insure complete worldwide communications at all times.

The "earth station" consists of a radome 210 feet in diameter and 161 feet tall. Inside is a 340-ton steel and aluminum rotatable antenna structure. It consists of a horn antenna with an opening that measures about 3,600 square feet and two fair-sized houses containing transmitter and receiving equipment. The horn will scoop up about a billionth of a watt of the signal broadcast from the Telstar satellite. A maser amplifier is located at the apex of the horn. It uses a synthetic ruby as a central element, cooled to  $-456^{\circ}\text{F}$  by liquid helium.

A supplementary control station located a quarter mile from the radome is where the actual work will be done. Two tracking antennas are located outside this building. A quad-helix command tracker picks up the satellite's 136-mc beacon and telemetry and will transmit commands to the satellite on about 120

mc. Once the satellite begins to transmit its broad-band communications signal and associated precision beacon, the other antenna, an 8-foot dish, will track on this signal with much greater precision. It controls the large horn in the radome through a servo system.

The Andover station will be linked to the Bell Telephone Network by conventional broad-band microwave radio relay system.

## People May Be Own Power Supplies

Persons who have electronic equipment such as Pacemakers or nerve stimulators implanted in their bodies, may in the future supply their own power to the equipment, according to Francis M. Long, assistant professor of electrical engineering at the University of Wyoming.

The power supply from implanted electronic equipment has always been a problem. When external batteries are used, connections must be made through the skin, with continuous danger of infection, as well as mechanical problems and annoyances. Pacemakers (heartbeat timers) have been made completely self-contained with both circuitry and batteries implanted in the body. In these cases, an operation every 5 years or so to renew the battery is necessary.

Experiments made by Professor Long would lead to the belief that a piezoelectric crystal, inserted where it would be subject to muscu-

lar motion, could supply enough power for such equipment. The crystal could be inserted, he suggests, in such places as between the diaphragm and the rib cage, and the motion caused by breathing would act on it as a phonograph stylus does on a similar crystal in a phonograph pickup, producing small but sufficient quantities of power for certain types of implanted equipment.

## New Electrostatic Recordings Are On Uncoated Tape

A new system of electrostatic recording in which the charge is injected into highly resistive tape (usually Mylar) was described at the recent IRE convention. The charges are injected into the body of the tape itself by drawing the tape over a knife-edge electrode, while its reverse side is in contact with the conducting backing electrode. As in magnetic recording, bias (dc or ac) can be used.

The playback system consists of a thin metallic "readout" electrode placed between two electrostatic shields. Tape is drawn across this as in a magnetic playback device. Potentials up to 40 millivolts are induced in the playback electrode.

After recording, and after each playback, the tape is neutralized with an "ion bath," produced by a high-voltage corona discharge from pointed electrodes, located between the recording or playback head and the pickup spool. This neutralizes any uncompensated charges that may have been produced by friction in reeling and unreeling. The process adds greatly to the life of the recording, reducing noise as well as print-through during storage.

A study of recordings now more than 3 years old leads to the belief that the new system yields a highly permanent recording, and a  
(Continued on page 12)



Earth station of Telstar satellite relay station at Andover, Me.

**Advertising Representatives:** Los Angeles: Harker-Husted-Coughlin, 408 1/2 South Alvarado St., Tel. DUnkirk 7-2328. San Francisco: Harker-Husted-Coughlin, 444 Market St., Tel. GARfield 1-0151. Atlanta: J. Sidney Crane & Associates, 22 Elghth St. N.E., Tel. TRInity 2-6720. Florida: New Associates, 15 Castle Harbor Isle, Fort Lauderdale, Fla. United Kingdom: Publishing & Distributing Co., Ltd., Mitre House, 177 Regent St., London, W. 1, England.

**Foreign Agents:** Great Britain: Atlas Publishing and Distributing Co., Ltd., 18 Bride Lane, London E.C. 4.

**Subscription Service:** Address form 3579 and correspondence to Radio-Electronics, Subscriber Service, 154 West 14th St., New York 11, N.Y. When requesting a change of address, please furnish an address label from a recent issue. Allow one month for change of address.

# We Really Mean It...When We Say

**YOU DON'T  
NEED...**

***A High School Diploma!***

***Previous Electronics Experience!***

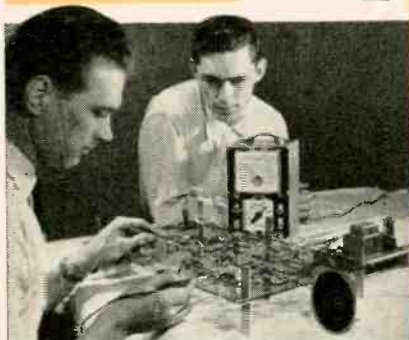

**TO PREPARE AT HOME THE DeVRY WAY FOR A  
JOB THAT PAYS *REAL MONEY* IN**

# Electronics!

**LET US TELL YOU WHY!**

**OUR INTEREST IN YOU MAKES THE BIG DIFFERENCE!**

In preparing you at home for a profitable job in the billion dollar opportunity field of electronics, DeVry Tech is more interested in your **DESIRE TO GET AHEAD** than we are in what you know about the field now. DeVry's training is thorough and practical. No previous electronic experience is required. We train you even if you don't know how to splice a lamp cord.

Our thorough training, with its many exclusive features such as home movies, has produced many graduates so well-trained, they have been employed by some of today's best-known firms and by scores of Radio and TV stations across the continent. DeVry Tech graduates are in demand. There are many job opportunities for them.

Becoming a DeVry Tech man in itself is a big lift. We have found through more than 30 years experience that by understanding a man's problems . . . by encouraging him in every way possible, we usually help him get the break he wants. It helps him do things he cannot do alone.

Another important benefit of becoming a DeVry Tech man is knowing you are part of an institution that not only trains you and helps you get started . . . but an organization that stands behind you on the job. It is such things as these that make DeVry Tech graduates **DIF-FERENT** . . . it makes them **PRE-FERRED** men by so many employers.

**Exclusive  
training  
movies help  
you learn  
FASTER!**

Why don't you send the coupon below for 2 FREE booklets . . . Mailing that coupon could be a big step forward . . . toward greater heights . . . better pay!

**DeVry Sends You Actual  
Equipment You Need At  
No Extra Cost!**

DeVry Tech, in addition to its exclusive training movies, sends you the practical "Electro-Lab" system which includes 16 shipments of equipment to work more than 300 learn-by-doing projects in your own home. We know of nothing more effective than DeVry Tech's tool-in-hand training.

**SEND FOR THESE**

**2 FREE**

**BOOKLETS**

Accredited member of National Home Study Council



**We Have Residential Training  
for High School Graduates**

**MILITARY SERVICE**  
We have valuable information for every man of draft age.

**EARN WHILE YOU LEARN**  
Practical training shows you how to earn good money in spare time.

**RESIDENT TRAINING**  
DeVry Tech has modern training centers in Chicago and Toronto.

**WORK IN THESE EXCITING FIELDS WHEN TRAINED!**

Radar • Guided Missile Control • Television • Radio  
Micro-Waves • Communications • Industrial Electronics  
Computers • Automation Electronics • Broadcasting  
Remote Control Systems • Your Own Service Shop

**DeVRY TECHNICAL  
INSTITUTE**  
CHICAGO • TORONTO

**DeVRY TECHNICAL INSTITUTE**

4141 Belmont Avenue • Chicago 41, Illinois • Dept. RE6-S

Please give me your two free booklets, "Pocket Guide to Real Earnings" and "Electronics in Space Travel"; also include details on how to prepare for a career in Electronics. I am interested in the following opportunity fields (check one or more):

- |  |  |
|--|--|
| <input type="checkbox"/> Space & Missile Electronics | <input type="checkbox"/> Communications          |
| <input type="checkbox"/> Television and Radio        | <input type="checkbox"/> Computers               |
| <input type="checkbox"/> Microwaves                  | <input type="checkbox"/> Broadcasting            |
| <input type="checkbox"/> Radar                       | <input type="checkbox"/> Industrial Electronics  |
| <input type="checkbox"/> Automation Electronics      | <input type="checkbox"/> Special "Short Courses" |

Name \_\_\_\_\_ Age \_\_\_\_\_

Address \_\_\_\_\_ Apt. \_\_\_\_\_

City \_\_\_\_\_ Zone \_\_\_\_\_ State \_\_\_\_\_

Check here if you face military service.

Canadian residents: Write DeVry Tech of Canada, Ltd.  
970 Lawrence Avenue West, Toronto 19, Ontario 2078



## NEW MODEL 644

SOUND SPOT MICROPHONE • LIST \$110.00

If you are in the commercial sound business, you have had your share of . . . "they couldn't be done" . . . jobs at one time or another in your business life. These jobs could not be solved because general purpose microphones just couldn't do the job. That, fortunately, is past history. E-V's new Model 644 ushers in a new era in the concept of microphone pick-up. So *take another look* and see how many of those "tough" jobs the 644 reclassifies to "simple and easy". Your local E-V distributor has all the details on the Model 644. See him today or write for complete data to Electro-Voice, Inc., Buchanan, Michigan, Dept. 622E.

**Electro-Voice®**

See the new E-V Model 644 at any of

### ARIZONA

Phoenix—Emmett Research Labs, 1309 East McDowell  
Phoenix—Kelton Audio Equipment Co., 806 N. First St.  
Tucson—Inland Electronic Supply, 715 East Broadway  
Tucson—Sound Shop, 4659 East Broadway

### ARKANSAS

Little Rock—Carlton Bates Co., 1210 East 6th Street  
Texarkana—Lavender Distributing, 522 E. Fourth St.

### CALIFORNIA

Bakersfield—Bakersfield Audio and Alarm,  
2534 "F" Street  
Berkeley—Pacific Radio Supply, 2801 Shattuck Ave.  
Culver City—Electronic Trading Post, 4364 Sepulveda  
Gardena—Stereo Hi Fi Center, 13996 Crenshaw Blvd.  
Glendale—Pacific Union Supply, 1545 North Verdugo  
Hollywood—Hollywood Radio Supply,  
5250 Hollywood Blvd.  
Hollywood—Pacific Radio Exchange, Inc.,  
1401-7 Cahuenga Blvd.  
Los Angeles—Arco Electronics, 111 South Vermont Ave.  
Los Angeles—Hannan Eng., 5500 W. Washington  
Los Angeles—Kierulff Sound Corp., 1015 Figueroa St.  
Los Angeles—Radio Products Sales, 1501 S. Hill St.  
North Sacramento—California Radio & TV Supply Co.,  
2537 Del Paso Blvd.  
Oakland—Fisher Electronics, 520 13th Street  
Oakland—Millers Radio & Television Supply, Inc.,  
530 East 8th Street  
Orangevale—Strayer Electronics, 9353 Greenback  
Sacramento—Lombards Electronics, 1827 Jay Street  
Sacramento—Norcal Electronics, 1115 "R" Street  
Sacramento—Sacramento Electronic Supply Company  
1219 "S" Street  
San Diego—Radio Parts Co., 2060 India Street  
San Francisco—Eber Electronics, 2385 Market Street  
San Francisco—House of Sound, 104 9th Street  
San Francisco—San Francisco Radio and Supply,  
1284 Market Street  
San Francisco—West Coast Electronics, 539 Market St.  
San Francisco—Zack Radio Supply, 1422 Market St.  
San Jose—Munday & Callins Audio Visual Center,  
270 Willow Street  
San Jose—Peninsula Electronics, 656 South First Street  
San Leandro—Styles & Engelman, 2255 Bancroft Ave.  
Santa Barbara—Channel Radio Supply, 18 E. Ortega  
Stackton—Dunlap Radio & Television Supply Company,  
27 South Grant Street

### COLORADO

Denver—Davis Audio Visual, 2149 South Grape Street  
Denver—Electric Accessories, 1620 Blake Street  
Denver—Empire Radio & TV Co., 1100 Broadway  
Denver—Interstate Radio & Supply, 1200 Stout Street  
Denver—L. B. Walker Radio Co., 300 Bryant Street  
Denver—L. B. Walker Radio Co., 100 North Victoria  
Grand Junction—L. B. Walker Radio, 537 N. 1st Street

### CONNECTICUT

Bridgeport—Harty of Bridgeport, 2465 Main Street  
New Haven—M & S Sound and Television Company,  
65 Kensington Street  
New London—Aikins Electronic Supplies, 531 Broad St.

### DELAWARE

Wilmington—Zomie Electronics, Fifth & French Street

### DISTRICT OF COLUMBIA

Washington—Capitol Radio Wholesalers,  
2120 14th Street, N.W.  
Washington—Electronic Wholesalers,  
2345 Sherman, N. W.  
Washington—Silberne Industrial Sales,  
3400 Georgia, N. W.

### FLORIDA

Miami—East Coast Electronics, 1900 N.W. Miami Ct.  
Sarasota—Hess Sound & Electronics, 1015 Gen. Spaatz  
West Palm Beach—Goddard Distributors, Inc.,  
1309 North Dixie

### GEORGIA

Atlanta—Specialty Distributing, 763 Juniper St., N.E.  
Atlanta—Southeastern Radio Parts, 400 W. Peachtree

### HAWAII

Honolulu—Precision Radio Ltd., 1160 South King Street

### ILLINOIS

Arlington Heights—Roy Bauman Music, 24 E. N.W. Hwy.  
Benton—Lampley Radio Co., 452 East Church Street  
Champaign—Electronic Parts Co., 905 South Neil St.  
Chicago—Allied Hi Fi Stores, Inc., 602 Davis Street  
Chicago—Allied Radio Corp., 100 N. Western Ave.  
Chicago—Allied Voice and Vision, 921 Rush St., North  
Chicago—Allied Voice and Vision, 7055 W. North Ave.  
Chicago—Evergreen Allied Hi Fi, Inc., 2025 W. 9th St.  
Chicago—Musicraft, 48 East Oak Street  
Chicago—Newark Electronics, 223 West Madison St.  
Peoria—Selectronic Supplies, Inc., 983 South Adams  
Quincy—Gates Radio Company  
Rockford—Elmqvist Sound and Communication,  
731 Seventh Street  
Rockford—Rockford Hi Fi, 120 N. Church  
Wood River—Audia Electronics, 932 Whitelaw Avenue

### INDIANA

Calumet—Prestan Sound Equipment, 910-25th St.  
Evansville—Ohio Valley Sound, 20 East Sycamore St.  
Gary—Casmopolitan Radio Co., 524 Washington St.  
Indianapolis—Graham Electronics, 122 South Senate  
Indianapolis—Meunier Radio Supply, 811 E. Michigan  
Indianapolis—Radio Distributing, 814 North Senate  
Logansport—Hill & San Sound Engineering, 2220 Spear  
Terre Haute—C. T. Evinger Co., 1216 Wabash Ave.  
West Lafayette—Robert C. Merchant Company,  
229 South River Road

### IOWA

Davenport—TCR Distributors, 1205 East River Drive  
Sioux City—Dukes Radio Company, 209 Sixth Avenue

### KANSAS

Wichita—Excel Distributors, 345 North Water  
Wichita—McClelland Sound, Inc., 229 West William

### KENTUCKY

Covington—American Sound, Inc., 675 West Third St.  
Lexington—Kenneth E. Smith, 598 Mitchell Avenue  
Louisville—Lewis Sound Service, 226 West Liberty St.  
Louisville—Peerless Electronic Equipment, 2210 S. 7th

### LOUISIANA

New Orleans—Crescent Electronic Supply, Inc.,  
537 South Claiborne Avenue

New Orleans—Epcor, 3622 Taulouse Street  
New Orleans—Radio Parts, Inc., 1112 Magazine St.  
New Orleans—Southern Radio Supply, 1909 Tulane

### MAINE

Portland—Maine Electronic Supply Corp. of Bangor  
148 Anderson Street  
Portland—Radio Service Lab., 1004 Congress Street

### MARYLAND

Baltimore—Kann-Ellert Electronics, 2030 Rock Rose Ave.  
Baltimore—Maynard E. Harp & Son, 2824 Loch Raven  
Baltimore—Radio Electronic Service, 5 North Howard  
Frederick—Hankeys Radio, Evergreen Place & Elm St.

### MASSACHUSETTS

Boston—DeMambo Radio Supply Company, Inc.,  
1095 Commonwealth Avenue  
Boston—Lafayette Radio, 110 Federal Street  
Boston—Radio Shack Corp., 730 Commonwealth Ave.  
Boston—E. A. Ross & Co., 341 Columbia Street  
Medford—East Coast Electronics, 296 Salem Street  
Southbridge—Charles Bastein, 95 Cole Avenue  
Springfield—Del Padre Supply, 999 Worthington St.

### MICHIGAN

Battle Creek—All Tronics, Inc., 3149 Fifth Avenue  
Detroit—Consolidated Sound Co., 20924 Harper Ave.  
Detroit—M. N. Duffy & Co., 2040 Grand River Ave.  
Detroit—Industrial Communications, 8300 Fenkell  
Detroit—KLA Laboratories, 7375 Woodward  
Detroit—Michigan Music Company, 15900 Hamilton  
Detroit—Radio Specialties Co., 12775 Lyndon  
East Lansing—Tape Recording Industries,  
1101 East Grand River Avenue

### MINNESOTA

Minneapolis—Audia King, 913 West Lake  
Minneapolis—Harry Starks, Inc., 112 North 3rd Avenue  
Minneapolis—Lew Bonn Company, 1211 LaSalle Ave.  
Minneapolis—Minnesota Audio Visual, 1012 Marquette  
Minneapolis—Northwest Sound Service, 73 Glenwood  
Rochester—S. M. Supply Co., 902 N.W. 7th Street

### MISSOURI

Cape Girardeau—Suedekum Electronic Supply Co.,  
2215 Broadway  
Kansas City—Burstin-Applebee, 1012-14 McGee  
Rolla—Shaw-Me Electronics, Inc., Highway 72, East  
St. Louis—Interstate Industrial Electronics, Inc.,  
8406 Olive Street Road  
St. Louis—Interstate Radionics, Inc., 4445 Custine Ave.  
St. Louis—Van Sickle Radio Electronics, 1113 Pine St.  
Sedalia—Radio & Television Supply, 321 East Main St.

### NEBRASKA

Lincoln—Scott Electronic Supply, 2201-07 "O" Street  
Scottsbluff—Jaachim Radio Supply, 1913 Broadway

### NEVADA

North Las Vegas—Electronics Specialties Company,  
3420 "C" East College Street

### NEW HAMPSHIRE

Concord—Evans Radio Co., Route 3A Bow Junction

### NEW JERSEY

Camden—General Radio & Supply Co., 600 Penn St.  
Camden—Radio Electric Service Co., 513 Cooper St.  
Elizabeth—Jersey Radio TV Supply, 1068 Elizabeth



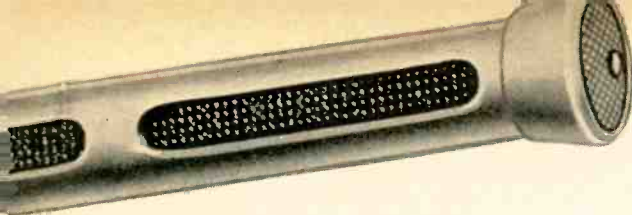

Now, after over 2 years of field testing, the 644 has thoroughly proved its ability to solve sound jobs previously thought impossible! If you haven't yet tried the 644, pick the job that other microphones couldn't "reach"... then find out for yourself why the 644 is the brightest new idea in microphones!

# those "impossible" sound jobs!

compare polar patterns yourself

## NON-DIRECTIONAL

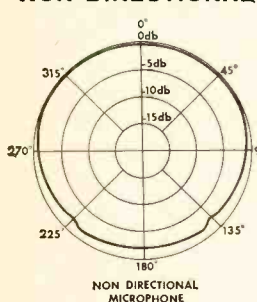

## CARDIOID

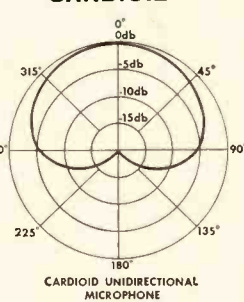

## SOUND SPOT

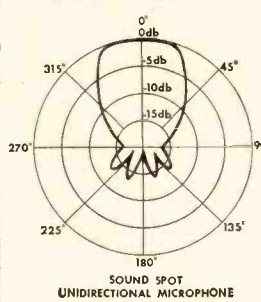

- Four times greater working distance than the best cardioids, depending on acoustics
- Greatly reduces feedback
- Retains "on-mike" presence despite extended working distance
- Excellent outdoors... less wind noise
- Priced low to fit most budgets
- Lasts a lifetime

Another better product for better sound from . . .

## ELECTRO-VOICE, INC.

Commercial Products Division • Loudspeakers-Microphones

BUCHANAN, MICHIGAN



## these Electro-Voice Microphone Headquarters

Hackensack—Nidisco Hackensack, 55 State Street  
 Jersey City—Nidisco Jersey City, Inc., 713 Newark Ave.  
 Mountainside—Federated Purchaser, Inc.,  
 1021 U.S. Route 22  
 Passaic—Nidisco Passaic, 294 Passaic Avenue  
 Ridgefield—Nidisco-Cliffside, Inc., 484 Bergen Avenue  
 Trenton—Nidisco-Trenton, Inc., 985 Princeton Avenue  
 Union City—Nidisco Jersey City, 2812 Hudson Blvd.

### NEW MEXICO

Albuquerque—Sound Equipment & Hi Fi House,  
 3011 Mante Vista Blvd., NE

### NEW YORK

Albany—Audio-Video Corp., 324 Central Avenue  
 Albany—Fort Orange Radio, 904 Broadway  
 Albany—Seiden Sound, Inc., 355 Central Avenue  
 Bethpage, L. I.—S & R Electronics,  
 4020 Hempstead Turnpike  
 Binghamton—Morris Distributing Co., 195 Water St.  
 Brooklyn—National Radio Parts Distributors,  
 572 Albany Avenue at Rutland Road  
 Buffalo—FM Sound Equipment, 1241 Main Street  
 Buffalo—Genesee Radio and Parts, 2550 Delaware  
 Buffalo—Radio Equipment Corp., 312 Elm Street  
 Carle Place, L.I.—E. J. Korvette, Incorporated  
 Glen Cove Road & Westbury Avenue  
 East Meadow, L.I.—Sound Service Engineers,  
 1788 Hempstead Turnpike  
 Elmira—Stack Electronics, 306 Railroad Avenue  
 Hempstead—Newmark and Lewis, 43 Main Street  
 Hempstead—Standard Parts, 277 North Franklin St.  
 Jamaica—Lafayette Radio Electronics, 165 Liberty Ave.  
 Middletown—Certified Electronics, Incorporated  
 Wickham Avenue Ext., Route 84  
 Mineola, L.I.—Arrow Electronics, 535 Jericho Turnpike  
 New York City—Airex Radio Corp., 85 Corland St.  
 New York City—Audio Unlimited, Inc., 190 Lexington  
 New York City—Florman & Babb, 70 West 45th St.  
 New York City—Harvey Radio Co., 103 West 43rd  
 New York City—Leonard Radio, 69 Corland Street  
 New York City—Magic-Vue Television, 323 E. 13th St.  
 New York City—Midway Radio & TV, 60 West 45th  
 New York City—Murray's Audio Center, 12 East 42nd  
 New York City—Sam Goody, Inc., 235 West 49th St.  
 New York City—Sonocraft Corp., 115 West 45th St.  
 New York City—Terminal Hudson, 48 West 48th St.  
 Rochester—Rochester Radio Supply, 600 East Main St.  
 Troy—Trojan Electronic Supply, 15 Middleburgh St.  
 Tuckahoe—Boynton Studio, 10 Pennsylvania  
 Utica—R. & H. Audio Visual Co., 227 Columbia Street  
 Yorkville—Valley Electronic Labs, Truck Route 5A

### NORTH CAROLINA

Asheville—Freck Radio & Supply Co., 38 Biltmore Ave.  
 Durham—Womack Electronics Supply, 601 Ramseur St.  
 Gastonia—Stroup Hi Fi Center, 112 Green Drive  
 Raleigh—Southeastern Radio Supply, 414 Hillsboro St.

### NORTH DAKOTA

Fargo—Walter Electronics Co., 402 North "P" Avenue

### OHIO

Akron—Electronic Engineering Co., Div. of Solsonid  
 Industries, Inc., 362 West Bowery Street  
 Canton—Burroughs Radio, Inc., 2705 Fulton Road, NW

Canton—Walker Radio, 1546 Fulton Road, NW  
 Cincinnati—Economy Electronic Distributing, 629 Elm St.  
 Cincinnati—Steinbergs, Inc., 633 Walnut Street  
 Cincinnati—Trout Company, 4815 Whetsel Avenue  
 Cleveland—Audiocraft Company, Inc., 2915 Prospect  
 Cleveland—Broadway Electric Supply Company, Inc.,  
 6207 Broadway Avenue, SE  
 Cleveland—Grossman Music Corp., 740 Bolivar Road  
 Cleveland—Olson Electronics, 6813 Pearl Street  
 Cleveland—Olson Electronics, 2020 Euclid Avenue  
 Cleveland—Pioneer Electronic Supply, 5403 Prospect  
 Cleveland—Progress Radio, 565 East 185th Street  
 Cleveland—Progress Radio, 13310 Miles Avenue  
 Cleveland—Progress Radio Supply Co., 415 Huron Rd.  
 Cleveland—Winteradio, 1468 West 25th Street  
 Columbus—Anderson Hi Fi Center, 2244 Neil Avenue  
 Columbus—Electronic Supply Corp., 814 West 3rd Ave.  
 Columbus—Hughes-Peters, Inc., 481 East 11th Street  
 Columbus—Olson Electronics, 142 North High Street  
 Columbus—Thompson Radio Supplies, 182 E. Long St.  
 Columbus—Whitehead Radio, 124 North Grant Ave.  
 Dayton—Custom Electronics, 1918 South Brown Street  
 Dayton—Srepcio, Inc., 314 Leo Street  
 Dayton—Stotts-Friedman Co., 108 N. Jefferson Street  
 Elyria—El-A-Company, 235 Lodi Street  
 Lima—Hutch on Son, Roberts at Lenore  
 Lima—Lima Radio Parts Co., 600 North Main Street  
 Middletown—Hinkles Electronics, 5021 Roosevelt Ave.  
 Parma—Winteradio Electronic Supply, 5373 Ridge Rd.  
 Toledo—Jamieson's Hi Fi Specialists, 3417 Dorr Street  
 Toledo—Tajedo Radio Specialties, 1215 Jackson St.  
 Toledo—Warren Radio Company, 1002 Adams Street  
 Youngstown—Armie's Electronics, 320 West Federal St.  
 Zanesville—Thompson Radio Supplies, 110 South 6th

### OKLAHOMA

Oklahoma City—Trice Wholesale Electronics,  
 4701 North Stiles  
 Tulsa—S & S Radio Supply, 537 South Kenosha

### OREGON

Pendleton—The Town Shop, 142 South Main

### PENNSYLVANIA

Altoona—Altoona TV Supply, Inc., 1720-22 Union Ave.  
 Braddock—M. Leff Radio Parts Co., 223 Brodock Ave.  
 Clifton Heights—Delaware Valley Electronics Supply,  
 224 Baltimore Pike  
 Cornwells Heights—Bucks County Sound and Recording  
 Laboratory, 2002 Newportville Road  
 Johnstown—Cambria Equipment, 17 Johns Street  
 McKeesport—Barno Radio Company, 927 Walnut Ave.  
 Philadelphia—AC Radio Supply, 1539 W. Passyunk  
 Philadelphia—Almo Radio Company, 913 Arch Street  
 Philadelphia—Barnett Brothers Radio, 622 Arch Street  
 Philadelphia—Friend's, 614 Arch Street  
 Philadelphia—Radio Electric Service Company,  
 NW Corner 7th and Arch Streets  
 Pittsburgh—Comcor Electronics, Inc., 937 Liberty Ave.  
 Pittsburgh—Hamburg Brothers, 213 Galveston Avenue  
 Pittsburgh—Radio Parts Co., Inc., 6401 Penn Avenue  
 Pittsburgh—South Hill Electronics, 1420 West Liberty  
 Pittsburgh—Tydings Electronics, Inc., 3337 Penn Avenue  
 Reading—George D. Barbey Co., 333 North Fourth St.

Wilkes Barre—Communications Engr., 41 N. Franklin  
 Wilkes Barre—General Radio and Electronic Co.,  
 396 South Main Street

### SOUTH CAROLINA

Charleston—Radio Labs, 475-477 East Bay Street  
 Columbia—Dixie Radio Supply Co., 1628 Laurel St.  
 Florence—Southern Electronics, 355-65 North Irby St.

### SOUTH DAKOTA

Aberdeen—Burghardt Radio Supply, 102 South Second  
 Rapid City—Burghardt Radio Supply, 726 Jackson  
 Sioux Falls—Burghardt Radio Supply, 208 N. Weber  
 Sioux Falls—Warren Radio Supply, 196 E. Sixth St.  
 Sioux Falls—Warren Supply Co., 115 S. Indiana Ave.  
 Watertown—Burghardt Radio Supply, 621-4th St., SE

### TENNESSEE

Memphis—Hirsch Electronics, 1658 Union Avenue

### TEXAS

Corpus Christi—Wicks Radio Equipment, 513 Staples  
 Dallas—Adleta Company, 1907 McKinney  
 Dallas—Chandler Sound Equipment, 3407 Ross Avenue  
 Dallas—Crabtree's Wholesale Radio, 2608 Ross Ave.  
 El Paso—Midland Specialty Co., 500 W. Paisano Drive  
 Fort Worth—Clifford Herring Sound Equipment,  
 1705 West 7th Street  
 Houston—Busacker Electronic Equipment, 1216 W. Clay  
 Houston—Sterling Electronics, Inc., 1616 McKinney  
 San Antonio—Vandergrift Audio, 4106 San Pedro Ave.

### UTAH

Ogden—Ballard Supply Co., 3109 Washington Blvd.  
 Ogden—Tri State Electronic Supply, 2763 Washington  
 Salt Lake City—Deseret Book Co., 44 East S. Temple  
 Salt Lake City—Electronic Sales, 175 Social Hall Ave.

### VERMONT

Burlington—Radio Service Lab, 703 Pine Street  
 White River Junction—Electronics Supply, Inc.

### VIRGINIA

Danville—Womack Radio & Supply, 513 Wilson St.  
 Hampton—Buckroe Electronics, Inc., 815 Buckroe Ave.  
 Norfolk—Cain Electronics, 14th and Monticello Avenue  
 Norfolk—Electronic Engineering, 4201 Hampton Blvd.  
 Norfolk—Priest Electronics, 6431 Tidewater Drive  
 Richmond—Radio Supply Co., 3302 West Broad Street  
 Roanoke—H. C. Baker Sales Co., Ltd., 19 Franklin Road

### WASHINGTON

Seattle—Western Electronic Supply, 717 Dexter Ave.  
 Seattle—Seattle Radio Supply, 2117 2nd Avenue  
 Tacoma—C & G Electronics, 2502 Jefferson Avenue  
 Yakima—Lay & Nord, 112 South Second Street

### WEST VIRGINIA

Charleston—Electronic Specialties Company,  
 Delaware at Randolph  
 Huntington—Electronic Supply, Inc., 422 11th Street  
 Wheeling—General Electronics Dist., 735 Main Street

### WISCONSIN

Appleton—Valley Radio Distributors, 518 N. Appleton  
 Madison—Satterfield Electronics, 1900 South Park St.  
 Milwaukee—Allied Radio, 5314 N. Port Washington  
 Milwaukee—Taylor Electric, 4080 N. Port Washington  
 Sheboygan—J. J. Koespell, South 9th at Commer



# LOWER THE COST OF FUN WITH VERSATILE TARZIAN TAPE



## Talk Long Distance for Only 10¢ per Hour

You can record a 24 minute conversation (at 3¾ i.p.s.) on a 225-foot reel of Tarzian Tape and mail it anywhere in the U.S. for 4¢ postage. No one worries about the telephone bill...and the same reel can be used again and again with no decrease in sound reproduction quality. That's a lot of friendly communication—the easy Tarzian Tape way. And you get a handy mailing carton as well!

## Turn Free Sound Waves into a Complete Music Library

Have you an AM or FM radio, or a TV set? If so, you can tape music and variety programs being broadcast every day—or, for that matter, borrow your friend's records and put them on tape. You'll pay for your tape recorder with the money you save on records—one inexpensive 1200 foot reel of high fidelity Tarzian Tape holds a full hour of music recorded at 7½ i.p.s.

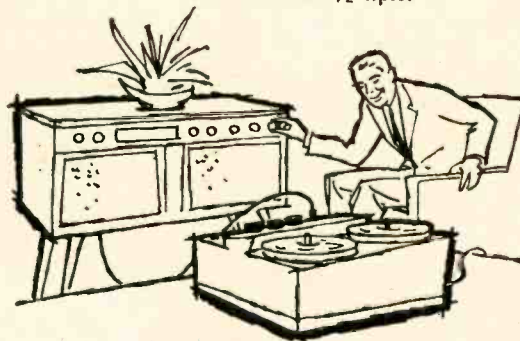

## Make a Priceless Family Heirloom—The Easy Tarzian Way

Next time the family gets together for a special occasion... and everytime a high point comes along in the lives of the children and grandchildren...be sure to record the events on long-lasting Mylar\*-base Tarzian Tape. The tape will last indefinitely—and so will your pleasure—with a priceless heritage of voices and events unique to your family. Such moments can seldom be repeated, but thanks to Tarzian Tape they can always be remembered.

## Buy, Borrow or Beg

Buy, borrow, or beg a reel of Tarzian Tape—either Mylar or acetate base, on a 3, 5, or 7-inch reel, and compare its sound reproduction to that of *any other tape* on the market. Your own ears will tell you why Tarzian is the best buy for modern tape recording. While you're at it, send for our free 32-page booklet, "The Care and Feeding of Tape Recorders".



*\*DuPont trademark for polyester film*



## SARKES TARZIAN, INC.

World's Leading Manufacturers of TV and FM Tuners • Closed Circuit TV Systems • Broadcast Equipment • Air Trimmers • FM Radios • Magnetic Recording Tape • Semiconductor Devices

**MAGNETIC TAPE DIVISION • BLOOMINGTON, INDIANA**

Export: Ad Auriema, Inc., N. Y. • In Canada, Cross Canada Electronics, Waterloo, Ont.

# how to get a Commercial FCC LICENSE

## An FCC License, Or Your Money Back!

Completion of the Master Course (both Sections) will prepare you for a First Class Commercial Radio Telephone License with a Radar Endorsement. Should you fail to pass the FCC examination for this license after successfully completing the Master Course, you will receive a full refund of all tuition payments. This guarantee is valid for the entire period of your enrollment agreement.

# FREE!

find out how . . .

1. You can get job security. Specialized education is the road to higher salary and important jobs in the growing field of electronics.
2. You can solve the problems that stump other technicians. Problems in electronics are becoming more complex. Your ability to solve problems will help you get ahead in your field.
3. You can handle new electronic devices. Every day, advances are being made in electronics. Only through education can you find out how to keep up with these developments and how to use the new devices.

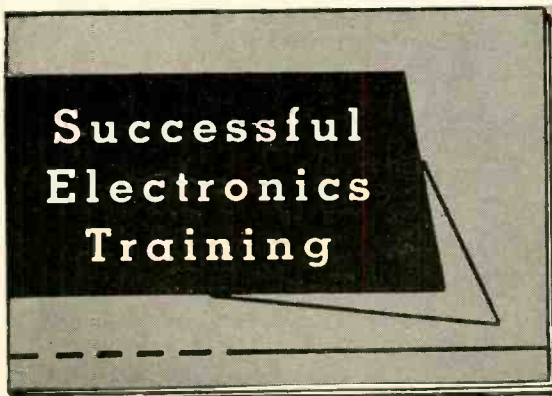

### Increase Your Technical Knowledge

Get a government license plus an understanding of such electronic applications as computers . . . industrial electronics . . . radar . . . communications . . . and many more

#### CLEVELAND INSTITUTE OF ELECTRONICS

1776 E 17th St. Desk RE66 Cleveland 14, Ohio

JUNE, 1962



good training  
doesn't cost . . .  
it pays!

## Get All 3 Booklets and This Handy Pocket Electronics Data Guide **Free**

Puts all the commonly used conversion factors, formulas, tables, and color codes at your fingertips. Yours absolutely free if you mail the coupon today. No further obligation.

### Sorry—Not For Beginners

Please inquire only if you really want to get ahead and to add to what you have already learned in school, in the service, or on the job. Some previous schooling or experience in electronics, electricity, or related fields is necessary for success in Cleveland Institute programs.

Accredited by the National Home Study Council

#### Cleveland Institute of Electronics

Desk RE66, 1776 E. 17th St., Cleveland 14, Ohio

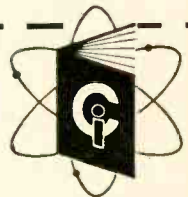

Please send Free Career Information prepared to help me get ahead in Electronics. I have had training or experience in Electronics as indicated below.

- |   |   |
|---|---|
| <input type="checkbox"/> Military           | <input type="checkbox"/> Broadcasting       |
| <input type="checkbox"/> Radio-TV Servicing | <input type="checkbox"/> Home Experimenting |
| <input type="checkbox"/> Manufacturing      | <input type="checkbox"/> Telephone Company  |
| <input type="checkbox"/> Amateur Radio      | <input type="checkbox"/> Other _____        |

In what kind of work are you now engaged?

In what branch of Electronics are you interested?

Name \_\_\_\_\_ Age \_\_\_\_\_

Address \_\_\_\_\_

City \_\_\_\_\_ Zone \_\_\_\_\_ State \_\_\_\_\_

RE66

for the  
1 family  
in 17  
that  
demands  
Recording  
Studio  
Quality  
from their  
tape  
recorder..



the **Norelco**<sup>®</sup>  
**Continental '400'**

People actively engaged in the musical arts—amateurs as well as professionals—are finding the Continental '400' the practical solution to the problems of complexity and cost posed by professional recording equipment.

Guild-crafted by Philips of the Netherlands—the Continental '400' offers professional quality recording and playback, both stereo and mono, at moderate cost for home use.

Completely self-contained with dual recording and playback preamps, dual power amplifiers, stereo-dynamic microphone and two stereo-matched wide-range Norelco loudspeakers.

**VERSATILITY:** 4-track stereo recording and playback, as well as 4-track monophonic recording and playback at any of its 3 speeds.

**FREQUENCY RESPONSE:** at 7½ ips, 50-18,000 cps; at 3¾ ips, 50-14,000 cps; at 1½ ips, 60-7000 cps.

**SIGNAL-TO-NOISE RATIO:** 48 db or better.

**WOW AND FLUTTER:** less than .15% at 7½ ips.

**CROSSTALK:** 55db. **HEAD GAP:** .00012".

For illustrated brochure on the entire line of Norelco tape recorders, write dept. F-6.

**NORTH AMERICAN PHILIPS COMPANY, INC.**  
High Fidelity Products Division  
**230 Duffy Ave., Hicksville, L. I., N. Y.**

In Canada and throughout the rest of the free world, the Norelco Continental is known as the 'Philips'.

(Continued from page 6)  
useful life greater than 100 years for Mylar tape records is predicted.

### Sunlight's Direction May Guide Satellites

According to Heinz Gabloffsky of the Northrop Space Laboratories, a satellite may be guided through space by detecting the position and direction of the sun. The information, fed to an electronic discriminator, which might be compared with the a/c system in television receivers and other electronic apparatus, would be used to correct the course of the satellite.

It is interesting to note that guidance by solar position is believed by some scientists to be a factor in the homing instinct of such insects as bees and of birds.

### Viewer "Sees Double" With TV Spectacles

A miniature television receiver worn like a headset permits the wearer to either watch a display on a monocle-like reflecting lens or to look through it at the scene ahead of him.

The device, called an Electrocular, was developed by a team from the Ground Systems Laboratory of the Hughes Aircraft Co. under the direction of Dr. A. Victor Stern. It is expected to be useful to persons who may require data or a second scene to be presented to them



Dr. A. V. Stern wearing the Electrocular.

while watching the scene ahead. A plane pilot, for example, could watch certain indicators without moving his eyes from the air area ahead, a tank commander could see the scene ahead of him as televised from an observation helicopter high in the air as well as the direct view from his tank, or a surgeon could scan information on the patient's respiration, heartbeat and other data while carrying on the operation. The lens, set at a 45° angle to the eye, permits the wearer to read information on it or look straight through it without being distracted noticeably by the other view.

The device consists of a miniature electrostatic TV tube, with a

prism to turn the picture 90° and project it on the lens, where it appears as a bright green image. A control unit supplies power, deflection and sync to both camera and receiver, thereby simplifying sync problems.

### "Home Broadcast Stations" Give Headaches to FCC

"Pee-wee broadcast stations," operated by children, have been creating "mounting difficulty" for FCC field engineers who have had to track down the irregular transmissions, which interfere with regular broadcasting as well as with aviation, police and other safety services. Many of the young people have no idea that there is anything illegal in such transmission, and the commission itself has received so many letters from youthful radio enthusiasts, inquiring how they can use a purchased kit or home-assembled equipment to broadcast voice and records to the immediate neighborhood without an FCC license, that it has put out a special bulletin of instruction to these correspondents. Known as *Information Bulletin No. 17-G*, it was issued in February, and contains 2½ pages of information as to what is legal in low-power radio and what is not. It points out that while certain types of equipment can be operated without a license, such equipment is constructed under strict controls designed to prevent interference with licensed radio services. The booklet also contains information for those who wish to pursue the study of radio, either as amateurs or as a career.

### Graeco-Schenectady

More than 550 terms ending in "tron" have been discovered by a British electronic magazine. These range from Accutron, an electronic watch, to Zyklotron, a high-frequency tube. Many of the terms are trademarks or company styles rather than names of electronic devices, and some (such as Shucktron, a device for removing the shells of oysters) are not electronic.

### Decade Counter Uses Luminescent Panel

A joint demonstration was made by Sylvania Electric Products and Beckman Instruments of a universal EPUT (Events Per Unit of Time) and timer which uses a luminescent panel numeric display instead of the familiar numeral display tubes. This was the first time that lumi-



# The Same School That Originated The RTS BUSINESS PLAN

**... NOW**  
Proudly  
Presents...

## A SPECIAL COMPACT COURSE COVERING ALL THREE PHASES OF **ELECTRONICS**

The Entire Course Is Made Up Of The Following:

- 35 LESSONS COVERING BASIC AND INTERMEDIATE ELECTRONICS
- 9 EQUIPMENT KITS COMPLETE WITH TUBES AND BATTERIES
- SOLDERING IRON
- 25 LESSONS COVERING THESE ADVANCED ELECTRONIC SUBJECTS:
  - Thyratron Tubes • Semiconductors • Electronic Symbols and Drawings • Voltage-Regulators • Electronic-Timers • Control Systems • X-Rays • Photoelectric Devices • Dielectric Heating • Geiger Counters • Pulse Circuitry • Clippers and Limiters • Multivibrators • Electronic Counters • Radar • Magnetic Amplifiers • Analog-Computers • DC Amplifiers • Digital Computers • Storage Systems • Input and Output Devices • Servomechanisms • Telemetering
- 60 EXAMINATIONS
- UNLIMITED CONSULTATION SERVICE
- KIT MANUALS
- DIPLOMA UPON GRADUATION

**BASIC • INTERMEDIATE • ADVANCED  
DESIGNED FOR THE BUSY MAN OF TODAY**

This is MODERN training for the MODERN man. You'll find no "horse and buggy" methods here. Every page of this streamlined course is devoted to important Electronics principles and practical projects. You'll be amazed how fast you grasp Electronics the RTS way. RTS has combined modern THEORY and PRACTICE to make this the finest training program of its kind available!

**SATISFIES NOVICE, TECHNICIAN OR HOBBYIST**

Whether you're new to Electronics or an old "pro," chances are you'll find this to be the ideal course for you. The novice will appreciate the completeness of the training. It starts with the most basic considerations, covering each important point thoroughly, yet concisely. The technician will enjoy the practical review of fundamentals and profit from the 25 advanced subjects covered.

**RTS GIVES YOU "TOP MILEAGE" FOR YOUR TRAINING DOLLAR**

The price quoted below buys EVERYTHING — there are no extras to pay for. RTS has gone "all out" to give you the best training value in America. Why pay hundreds of dollars for training such as we offer when it's available for this LOW PRICE? If you can find a better training bargain... BUY IT!

**CAN BE COMPLETED IN MONTHS INSTEAD OF YEARS**

Some students will complete this course with "Jet-Like" speed but we allow up to two years if your circumstances require it. You study at your own rate. You are ENCOURAGED but not pushed. You'll find the lessons professionally written but easy to understand. LET US SEND YOU ONE OF THESE LESSONS ALONG WITH YOUR CAREER BOOKLET SO YOU CAN SEE FOR YOURSELF. NO OBLIGATION!

AND MUCH MORE...

RTS' Membership in The Association of Home Study Schools is your assurance of Reliability, Integrity and Quality of Training.



**RTS ELECTRONICS DIVISION**  
815 E. ROSECRANS AVENUE  
LOS ANGELES 59, CALIFORNIA

Est. 1922



L 201 B

COMPLETE  
COST...  
INCLUDES ALL KITS,  
TUBES, BATTERIES, ETC.  
**\$125<sup>00</sup>\***

**Rush  
Coupon**

**NO  
SALESMAN  
WILL  
CALL!**

\* TERMS ALSO AVAILABLE  
AS LITTLE AS

\$500 DOWN \$500 PER MONTH

**SAVE TIME — SEND  
\$5.00 WITH COUPON**  
YOUR FIRST LESSONS AND  
KIT WILL BE RUSHED TO YOU  
THE SAME DAY THEY ARE RECEIVED!

**DON'T LOSE OUT — FIND OUT!**

RTS ELECTRONICS DIVISION, Dept. RE-62  
815 E. ROSECRANS AVENUE LOS ANGELES 59, CALIFORNIA

Rush me full information by return mail. (Please Print)

Name \_\_\_\_\_ Age \_\_\_\_\_

Address \_\_\_\_\_

City \_\_\_\_\_ Zone \_\_\_\_\_ State \_\_\_\_\_

**ENROLL ME NOW**  **SEND MORE FACTS**

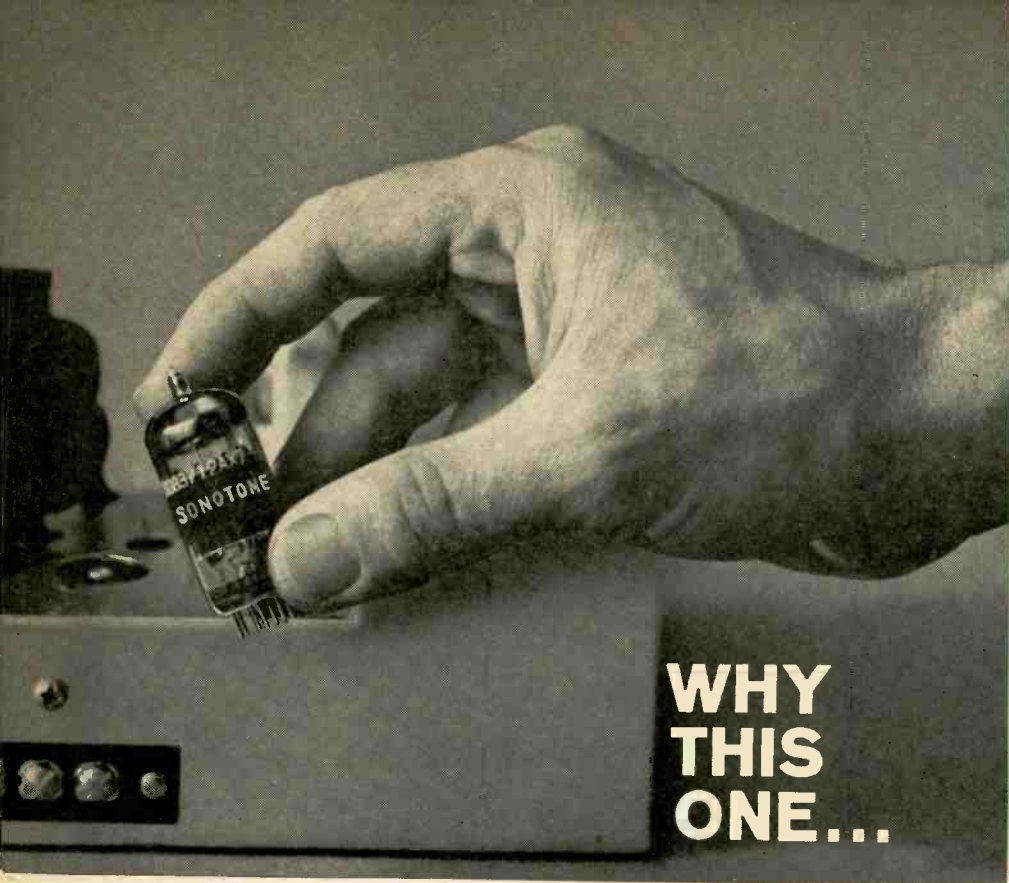

**WHY  
THIS  
ONE...**

## and not just any 12AX7A?

All 12AX7A schematics look alike. And at first glance, all 12AX7A tubes also look alike. Yet, the use of a Sonotone 12AX7A tube can make a world of difference in performance.

The 12AX7A, used in signal stages for high gain, has virtually become the standard in the low level stages of audio preamp circuits where noise, hum and tube microphonics become major problems. If you examine a Sonotone 12AX7A closely, alongside another, you will see a significant difference in construction. You will notice a trident shaped, tongued structural member at the top of the tube — called a "Damper Mica." The tongue supports the two cathodes — acts like the leaf of a spring, absorbing the shock of external impact and vibration.

As a result of this unique construction, the Sonotone 12AX7A is remarkably free from microphonic tendencies. It is also sturdier and more capable of withstanding impact and vibration without physical damage or electrical malfunction.

In addition, the Sonotone 12AX7A employs a coiled heater which restricts unwanted magnetic fields in the heater cathode assembly when AC is used for the heater supply. This reduces the AC hum component to a point where it is no longer necessary to use rectified and filtered heater supplies.

Small wonder that the Sonotone 12AX7A is specified by the leading manufacturers of high fidelity amplifiers. It is their way of insuring the quality of their instruments.

The next time you replace a 12AX7A, remember that not all of them are alike. There are enough distinctive qualities in the Sonotone 12AX7A to make its choice a sure and safe one. That's the point about all Sonotone tubes—all have that extra something that spells better performance.

In addition to the high-gain 12AX7A, Sonotone also features selected quality audio output tubes—the EL34 and EL84—available in matched pairs for push-pull applications.

Next time the schematic calls for the 12AX7A, or any type of tube for home entertainment or industrial application — replace with Sonotone.

# SONOTONE® CORPORATION

**ELECTRONIC APPLICATIONS DIVISION • ELMSFORD, NEW YORK**  
Cartridges • Speakers • Tape Heads • Mikes • Electron Tubes • Batteries • Hearing Aids

nescent material has been presented commercially in such a device, although luminescent panels have been used for flashing signs. The completely solid-state material operates at about 250 volts and 400 cycles. The luminescent display makes readings from wide angles possible, and eliminates any confusion due to the stacked digits of the tube type display devices. Switching time is fast, the decay time of the material having a maximum of about 5  $\mu$ sec.

### Calendar of Events

**1962 Electronic Parts Distributors Show**, May 21-24, Conrad Hilton Hotel, Chicago. Attendance limited to manufacturers, distributors, representatives and their advertising agencies. RADIO-ELECTRONICS will exhibit in Room 610.

**ISA National Aero-space Instrumentation Symposium**, May 21-23, Marriott Twin Bridges, Motor Hotel, Washington, D. C.

**IRE, AIEE, ASME, ISA National Telemetering Conference**, May 23-25, Sheraton Park Hotel, Washington, D. C.

**EIA Annual Convention**, May 23-25, Pick-Congress Hotel, Chicago, Ill.

**IRE Seventh Region Space Communications Conference**, May 24-26, Seattle, Wash.

**ERA Management Institute**, June 10-15, University of Illinois, Urbana, Ill.

**IRE Spring Conference on Broadcast and TV Receivers**, June 18-19, O'Hare Inn, Chicago.

**IRE National Convention on Military Electronics**, June 25-27, Shoreham Hotel, Washington, D. C.

**Symposium on Electromagnetic Theory & Antennas**, June 25-30, Technical University of Denmark, Copenhagen.

**IRE, AIEE, ISA, ASME, AICHE Joint Automatic Control Conference**, June 27-29, New York University, New York, N. Y.

**IRE National Symposium on Radio Frequency Interference**, June 28-29, Town House Hotel, San Francisco, Calif.

**National Bureau of Standards Course in Radio Propagation**, July 16-Aug. 3, Boulder Labs, Boulder, Colo.

### Magnetic Field Improves Thermoelectric Material

The properties of a thermoelectric material may be greatly improved by placing it in a magnetic field, according to Bell Telephone scientists Raymond Wolfe and

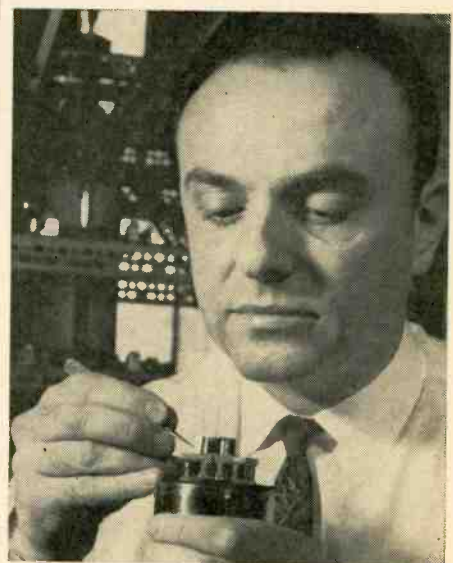

**Raymond Wolfe of Bell Telephone Labs prepares to replace conventional n-type thermoelectric material with new bismuth-antimony alloy.**

(Continued on page 18)

# are you standing still in electronics while this man advances?

*Find out why—and do something about it—if you have the ambition to want a career instead of just a job.*



CREI graduate Mearl Martin, Jr. has progressed from Junior Technician to licensed Senior Engineer. He is now Field Support Manager, Marketing Division of Tektronix, Inc., Portland, Oregon.

**LET'S LOOK AT THE FACTS.** There's something wonderful about knowing how a circuit works or what a filter capacitor does. If you've ever fixed a TV set, built a radio or used a voltmeter, you've tasted the thrills of electronics.

This excitement may have led you to a job in electronics. But the glamour fades if you are stuck in the same job year after year. You'll be bored with routine and unhappy about prospects for future earnings. You'll discover, as have many men, that simply working in electronics does not assure a good future.

If electronics is the "field of opportunity," how is this possible? No question about it, electronics offers many opportunities, *but only to qualified men.* In any career field, it is how much you know that counts. This is particularly true in the fast moving field of electronics. The man without thorough technical education doesn't advance. Even men with intensive military technical training find their careers can be limited in civilian electronics.

**ADVANCED TECHNICAL KNOWLEDGE IS THE KEY** to success in electronics. If you have a practical knowledge of current engineering developments, if you understand "why" as well as "how," you have what employers want and pay for. With such qualifications, you can expect to move ahead.

**CREI OFFERS YOU**, for study at home, a complete program in electronic engineering technology designed to prepare you for a rewarding, well-paying career in electronics. CREI equips you with a practical working knowledge of advanced and up-to-date electronic developments that will put you on the level of specialization where men are most in demand.

**CREI MEN LIKE MEARL MARTIN, JR.** hold positions as associate engineers, engineering aides, field engineers, project engineers and technical representatives.

**WHEN YOU ENROLL IN A CREI HOME STUDY PROGRAM**, you study courses to which a number of today's leading engineers and scientists have made substantial contributions. You are guided and assisted by CREI's staff

of experienced instructors. You study texts that are specifically prepared for home study use.

Through CREI, you have a choice of programs covering every field of electronics:

- RADAR • COMPUTERS • SERVOMECHANISMS • INSTRUMENTATION • AERONAUTICAL AND NAVIGATIONAL • COMMUNICATIONS • TELEVISION • AUTOMATION AND INDUSTRIAL ENGINEERING TECHNOLOGY • NUCLEAR ENGINEERING TECHNOLOGY**

Programs are available for men, such as engineers, who already have extensive technical knowledge, as well as for men with limited technical training or experience.

**THE HIGH CALIBRE OF A CREI HOME STUDY EDUCATION** is attested to by America's biggest corporations, where CREI students and alumni attain positions ranging from engineering technicians to engineers to top officials. Such companies are National Broadcasting Company, Pan American Airways, Federal Electric Corporation, The Martin Company, Northwest Tele-

phone Company, Mackay Radio, Florida Power and Light and many others. They not only recognize CREI Home Study educational qualifications but often pay all or part of CREI tuition for their employees.

**CREI HOME STUDY PROGRAMS** are the product of 35 years of experience. Each program has been developed with the same painstaking skill and care that CREI put into its electronics courses for the Army Signal Corps, its special radio technician courses for the Navy, and its group training programs for leading aviation and electronics companies. For those who can attend classes in person, CREI maintains a Residence School in Washington, D. C.

**YOU CAN QUALIFY** for a CREI Program, if you have basic knowledge of radio or electronics and are a high school graduate or the equivalent. If you meet these qualifications, write for **FREE 58-page book** describing CREI Programs and career opportunities in advanced electronic engineering technology. Use coupon below, or write to: The Capitol Radio Engineering Institute, Dept. 1406-K, 3224 Sixteenth St., N. W., Washington 10, D. C.

Mail coupon today for **FREE 58-page book**

## THE CAPITOL RADIO ENGINEERING INSTITUTE

Founded 1927  
Dept. 1406-K, 3224 Sixteenth St., N.W., Washington 10, D.C.

Please send me details of CREI Home Study Programs and Free Book, "Your Future in Electronics and Nuclear Engineering Technology." My qualifications are noted to obtain immediate service.

- CHECK FIELD OF GREATEST INTEREST:**
- Electronic Engineering Technology
  - Servo and Computer Engineering Technology
  - Nuclear Engineering Technology
  - Automation and Industrial Electronic Engineering Technology
  - Aero and Navigational Engineering Technology

Name ..... Age .....

Address .....

City ..... Zone ..... State .....

Employed by .....

Type of present work .....

Education: Years High School ..... Other .....

Electronics Experience .....

Check:  Home Study  Residence School  G.I. Bill # 26



# What sets the stage for scientific discovery?



H. E. D. Scovil, pioneer developer of the solid state microwave maser, explains a point at a symposium at Bell Telephone Laboratories.

There is no one answer. But surely discovery is more likely when people are stimulated to think in new ways. And nothing more powerfully stimulates scientists and engineers than up-to-the-minute discussion of the latest developments.

Bell Laboratories scientists and engineers make a point of exchanging information on their latest advances not only among themselves but with the great world-wide professional community to which they belong. Last year, for example, Bell

Laboratories specialists delivered over 1200 talks to technical societies and universities. The stimulating exchange of new ideas plays an indispensable role at the world center of communications research and development.



## Bell Telephone Laboratories



# GET YOUR First Class Commercial F.C.C. LICENSE IN 12 WEEKS!

## Is the course proven?

A high percentage of our fulltime resident students get their 1st class licenses within 12 weeks from the time they start the course. Intensive FCC license training is our specialty — not just a sideline.

## Is the course complete?

The Grantham course covers all the required subject matter completely. Even though it is planned primarily to lead directly to a first class FCC license, it does this by TEACHING you electronics.

## Is the course "padded"?

The streamlined Grantham course is designed specifically to prepare you to pass certain FCC examinations. All of the instruction is presented with the FCC examinations in mind. If your main objective is an FCC license and a thorough understanding of basic electronics, you want a course that is right to the point — not a course which is "padded" to extend the length of time you're in school. The study of higher mathematics or receiver repair work is fine if your plans for the future include them, but they are not necessary to obtain an FCC license.

## Is it a "coaching service"?

Some schools and individuals offer a "coaching service" in FCC license preparation. The weakness of the "coaching service" method is that it presumes the student already has a knowledge of technical radio. On the other hand, the Grantham course "begins at the beginning" and progresses in logical order from one point to another. Every subject is covered simply and in detail. The emphasis is on making the subject easy to understand. With each lesson, you receive an FCC type test so you can discover daily just which points you do not understand and clear them up as you go along.

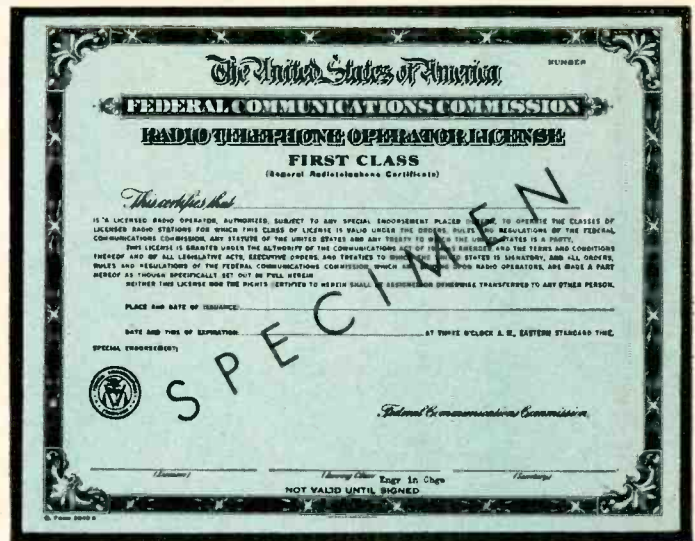

## Is the course guaranteed?

The now famous Grantham Guarantee protects your investment. When such "insurance" is available at no extra cost, why accept less?

## Is it a "memory course"?

No doubt you've heard rumors about "memory courses" and "cram courses" offering "all the exact FCC questions." Ask anyone who has an FCC license if the necessary material can be memorized. Even if you had the exact exam questions and answers, it would be much more difficult to memorize this "meaningless" material than to learn to understand the subject. Choose the school that teaches you to thoroughly understand — choose Grantham School of Electronics.

**THE GRANTHAM FCC License Course in Communications Electronics is available by CORRESPONDENCE or in RESIDENT classes.**

# Grantham Schools

1505 N. Western Ave.  
Los Angeles 27, Calif.  
(Phone: HO 7-7727)

408 Marlon Street  
Seattle 4, Wash.  
(Phone: MA 2-7227)

3123 Gillham Road  
Kansas City 9, Mo.  
(Phone: JE 1-6320)

821 - 19th Street, N.W.  
Washington 6, D. C.  
(Phone: ST 3-3614)

## FIRST CLASS F.C.C. LICENSE IN 12 WEEKS

Grantham resident schools are located in four major cities — classes in F. C. C. license preparation are offered at all locations. New day classes begin every three months, and new evening classes begin four times a year.

**MAIL COUPON NOW — NO SALESMAN WILL CALL →**

Accredited by the National Home Study Council

(Mail in envelope or paste on postal card)

To: **GRANTHAM SCHOOL OF ELECTRONICS**

1505 N. Western • 408 Marion • 3123 Gillham Rd. • 821-19th, NW  
Los Angeles • Seattle • Kansas City • Washington

Please send me your free booklet telling how I can get my commercial F.C.C. license quickly. I understand there is no obligation and no salesman will call.

Name \_\_\_\_\_ Age \_\_\_\_\_

Address \_\_\_\_\_

City \_\_\_\_\_ State \_\_\_\_\_

I am interested in:  Resident Classes

Home Study

24-G

## IN P.A. SPEAKERS as in Mike Stands ATLAS SOUND offers

- FULL LINE
- QUALITY
- PROFIT
- SERVICE

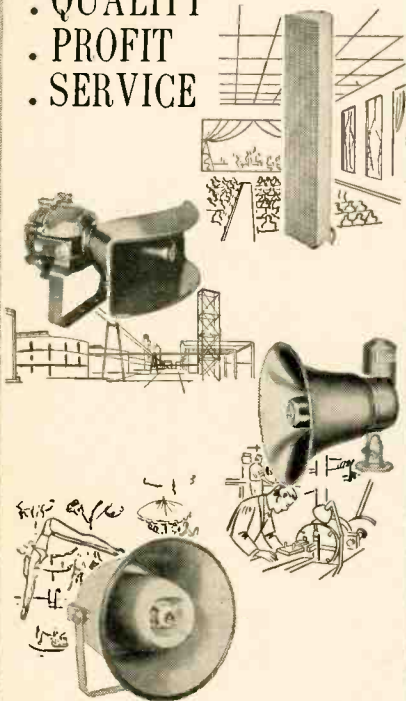

You name the application, there's an Atlas "job-rated" speaker just perfect for the task. Engineered to the latest state of the art, built for long life, priced right for your profit, supplied to serve all your needs. All with the same quarter-century know-how that brings you...

## EVERYTHING IN MIKE STANDS & ACCESSORIES

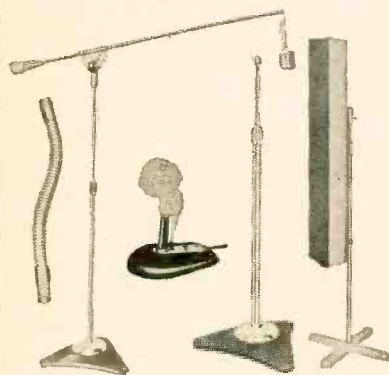

In addition to offering a stand for every purpose, only Atlas is ready and equipped to serve you with a complete line of support accessories, fittings and hardware so important to a well engineered and professional sound installation.

Write for full details  
and latest catalog.



**ATLAS SOUND DIVISION**  
American Trading and Production Corporation  
1419-51 39th Street, Brooklyn 18, New York  
Canada: Atlas Radio Corporation, Toronto

(Continued from page 14)

George E. Smith. They report that the figure of merit of an alloy of 88% bismuth and 12% antimony was raised from 1.2 to  $2.9 \times 10^{-3}$  per degree K, at room temperature, with a magnetic field of 17,000 gauss.

The figure of merit, or "Z", is an expression which tells how much electricity can be obtained from a thermoelectric junction and is related to the voltage produced by a given amount of heat applied to the junction, to the resistivity of the material and to its thermal conductivity. At a temperature of 100°K, a record-breaking Z of  $8.6 \times 10^{-3}$  per degree K was reported, with a field of only 1,000 gauss.

The improved material and techniques should find immediate application in low-temperature electronic refrigeration. The magnetic field technique may be applicable to other thermoelectric materials.

### Pay TV With a Difference

A pay-TV system that does not mean a takeover of TV servicing was announced for Denver, Colorado by the Gotham Broadcasting Corp. and the Macfadden-Bartell Corp. when they revealed the filing of an

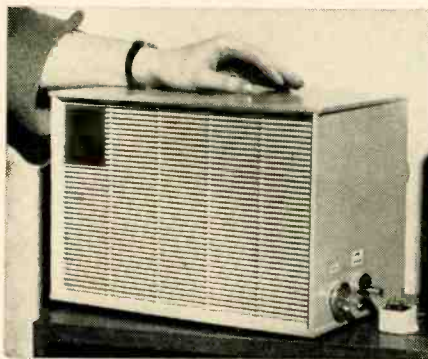

application with the FCC for authorization to conduct a 3-year test of the system. The different thing about the Teleglobe pay TV system is that the picture is transmitted unscrambled. Sound is piped into a separate amplifier-speaker unit via telephone lines. Therefore, no connections are made to the TV receiver and it can be serviced just as any receiver. Connections to the pay-TV audio channel have nothing to do with the TV set, as a separate amplifier speaker assembly supplied by Teleglobe (see photo) is used. When the user turns on the audio system its use is recorded electronically at the Teleglobe-Denver data processing center. The customer is then billed monthly according to what he watched.

### Electronic Engineers Meet

Again breaking records of all previous conventions, the Institute of Radio Engineers was host to some 73,479 of the world's leading experts in electronics, space technology and communications at its fiftieth anniversary convention in New York

City, March 26-29. A 4-day technical program saw the presentation of 265 papers in 54 technical sessions which covered everything from space electronics to artificial intelligence.

The most startling new development exhibited was the disintegration of a small portion of a stainless steel sheet with a light beam from a laser. After burning a hole through 1/32-inch steel in .0005 second, the beam continued on its way to blow up a balloon lying on a table some 10 feet distant.

The IRE's annual electronic exhibition consisted of more than 850 separate exhibits, completely filling four floors of the New York Coliseum.

One of the important pieces of business of the convention was to continue arrangements for merging the IRE with the American Institute of Electrical Engineers. If the merger is approved by the members of both societies, this may be the last convention of the IRE. The next one would be of the Institute of Electrical and Electronic Engineers. It was remarked by one visitor that the time is ripe for such an eventuality, since among the more than 800 exhibits, there were apparently only two or three that included radio—the rest were purely electronic.

### Brief Briefs

Standard frequencies transmitted by the National Bureau of Standards and the US Naval Observatory were made higher by two parts in one billion, beginning Jan. 1, 1962. The change is too small to be detected by ordinary equipment, but is significant to those using specialized apparatus.

Claimed to be the smallest cardiac pacemaker, this little instrument is 2 inches square and 3/8 inch thick. Worn externally, it weighs

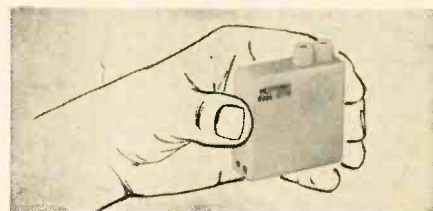

only 4 ounces, including a 6-month battery. Bipolar electrodes connect it directly to the heart's myocardium, to regulate the heartbeat.

A battery that operates on sugar with a combination of catalysts, to produce current at 0.7 volt, is announced by Electro-Optical Systems of California and Sonotone Corp. of New York. Such batteries, it was stated, might theoretically be usable to produce electricity on space craft, using human waste as fuel.

Weathers Industries, Barrington, N. J., of the famous Weathers pickup, has been acquired by TelePrompTer Corp. Paul Weathers becomes director of engineering for the new TelePrompTer Div. END

**BRILLIANT**  
 build-your-own  
**STEREO FM**  
 MULTIPLEX TUNER

*no comparable tuner value in the kit field*



there's matchless quality in the **knight-kit**<sup>®</sup>

ONLY **\$99<sup>95</sup>**

**SEND NO MONEY**

only \$6 per month

**HERE'S THE PROOF OF QUALITY AND VALUE**

- Built-in multiplex circuit for FM stereo—nothing else to add
- Wideband FM circuit for full-range reception •  $1\frac{1}{2}\mu\text{v}$  IHFM usable sensitivity • DSR (Dynamic Sideband Regulation) virtually eliminating distortion in weak and/or overmodulated FM signal reception
- Variable AFC for drift-free listening and "locked-in" tuning
- Dimension Control with StereoFinder—adjusts channel separation for optimum stereo effect, even with widely spaced speakers
- "Magic Eye" indicators—moving bar-type for precise on-station tuning
- Weighted flywheels for effortless FM or AM tuning
- Multiplex position on selector for instant switching from stereo to monophonic reception
- Customized AM section for high sensitivity—choice of narrow and wide IF bandwidth; • 10-kc whistle filter
- Built-in loopstick antenna
- All printed board circuitry
- RF and IF transformers factory aligned
- Outputs are cathode-follower type with individual level set controls
- Beautiful case with extruded aluminum panel
- Includes all parts, wire, solder, and famous Knight-Kit step-by-step instructions.  $4\frac{1}{2} \times 15\frac{1}{2} \times 15"$  • For 110-125 v. 60 cycle AC. Shpg. wt., 29 lbs.



*typical of the value and quality of over  
 100 other great KNIGHT-KITS*

**ALLIED RADIO**  
**KNIGHT ELECTRONICS DIVISION**

**KF-90 STEREO MULTIPLEX  
 FM-AM TUNER KIT**

dazzling stereo FM plus AM...lavish features

America's best tuner buy! Fully equipped for breathtaking stereo FM multiplex reception, this easy-to-build, expertly engineered tuner is yours at unbelievably low cost. Features advanced built-in multiplex circuitry for sparkling FM stereo reception, as well as sensitive regular monophonic FM and AM reception—all from a single self-contained beautifully styled tuner. Outstanding highlights:  $1\frac{1}{2}\mu\text{v}$  IHFM usable sensitivity on FM for real "pull-in" power—terrific for fringe areas; unique StereoFinder to locate stereocasting stations—Dimension Control "finds" multiplex signal, then lets you adjust for best stereo effect. Dozens of other superb features (see left). The quality can't be matched; the savings can't be duplicated. Order the Knight-Kit KF-90 today—*no money down* (just check coupon). **\$99<sup>95</sup>**

*Satisfaction guaranteed or your money back*

**SEND NO  
 MONEY**  
 order today

**ALLIED RADIO**  
 100 N. Western Ave., Chicago 80, Ill.

- Ship me the Knight-Kit KF-90 Tuner 83 YU 914AN
- Ship No Money Down on Allied's Credit Fund Plan

Name \_\_\_\_\_  
PLEASE PRINT

Address \_\_\_\_\_

City \_\_\_\_\_ Zone \_\_\_\_\_ State \_\_\_\_\_



# 5 WAYS TO SAVE MONEY ON YOUR TV REPAIRS

For window-size blow-ups  
of this message, send 10¢ to  
Sprague to cover handling  
and mailing costs.

# 1

### **DON'T BE A "SCREWDRIVER MECHANIC."**

Every year, hundreds of "do-it-yourself-ers" damage or ruin their sets, pile up needless expense, and endanger their safety by trying to make their own TV repairs. Your TV is the most intricate piece of equipment you've ever owned—far more complicated than your car! If you're tempted to tinker with it, DON'T! Guesswork is much too costly.

# 2

### **LEAVE YOUR TV REPAIRS TO A "PRO."**

Years of training and experience make the TV technician an expert. He has repaired hundreds—perhaps thousands—of TV sets. He spends countless hours and hundreds of dollars on manuals, keeping up-to-the-minute on new developments, circuits, trouble-shooting techniques. He is qualified in every way to diagnose TV trouble accurately—cure it quickly and safely.

# 3

### **DON'T LOOK FOR SERVICE "BARGAINS."**

There aren't any! Cut-rate prices mean cut-rate methods and cut-rate parts in your TV set. And these lead to unsatisfactory set performance, probable damage, and additional costly repairs. The expert TV technician charges a fair price for honest service. He can't afford special deals and service "bargains" any more than you can!

# 4

### **CALL YOUR TV EXPERT AT THE FIRST SIGN OF TROUBLE.**

Don't wait for your set to go completely dead. Failure of one TV part sets up a chain reaction—other parts are damaged and repair costs pile up. Early attention prevents this and also makes it easier—and less expensive—to find and cure the trouble. To keep your repair costs low, call your TV technician when trouble *starts!*

# 5

### **TRUST YOUR INDEPENDENT TV TECHNICIAN.**

As a member of your community, he stakes his reputation on your continued satisfaction. His years of study and experience, his large investment in equipment, and the fact that *he's in business for himself* are your assurances of good work and honest prices. His first loyalty is to *you*—his customer.

**THIS MESSAGE WAS PREPARED BY SPRAGUE PRODUCTS COMPANY,  
DISTRIBUTORS' SUPPLY SUBSIDIARY OF SPRAGUE ELECTRIC COMPANY, NORTH ADAMS, MASSACHUSETTS FOR . . .**

**YOUR NEIGHBORHOOD TV-RADIO TECHNICIAN**



**NEW SWITCH  
NEW COMFORT  
NEW STYLE**

**TURNER'S NEW**

# **355C CITIZEN'S BAND MICROPHONE**

An all new styling concept from Turner—the company that gave you the famous Turner 350C microphone. Now, with the 355C you get the same Turner rugged-

ness and dependability in an entirely new microphone design. The convenient hand-ease switch means fast and convenient operation in any mobile situation.

*See Turner's new 355C  
at the Parts Show,  
Booth E-105, Suite 1204.*



**THE MICROPHONE COMPANY**

952 17th Street N.E., Cedar Rapids, Iowa

IN CANADA: Tri-Tel Associates, Ltd., 81 Sheppard Avenue West, Willowdale, Ontario

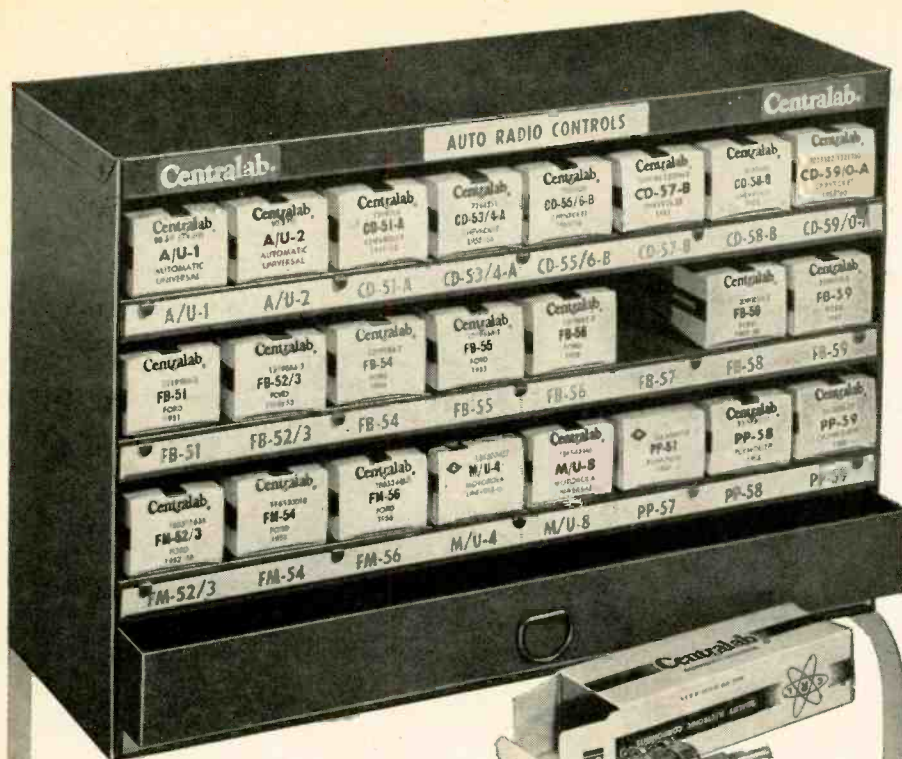

# FREE ROLLER SKATES

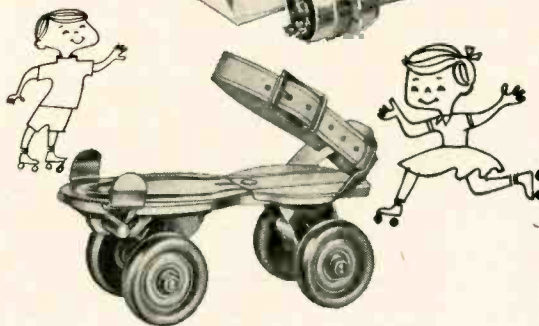

with each Centralab ACK-100

## AUTO RADIO CONTROL KIT

**YOU GET:**

24 of today's fastest movers

*PLUS*

- free sturdy steel cabinet

*PLUS*

- auto-radio control cross reference

*PLUS*

- free roller skates

**ONLY \$49<sup>95</sup> THE PRICE OF THE CONTROLS ALONE!**

See your distributor now!—Offer will be withdrawn when supplies are exhausted.

Centralab controls are listed in Sams' TV & Auto-Radio Control Replacement Guide.



THE ELECTRONICS DIVISION OF GLOBE-UNION INC.

922F EAST KEEFE AVENUE • MILWAUKEE 1, WISCONSIN

In Canada: Centralab Canada Ltd., P.O. Box 400, Ajax, Ontario

B-6227S

## Correspondence



### RADIATION NOTES

Dear Editor:

It must be a great comfort to know that when the needle on Mr. McCreedy's radiation meter (February 1962, page 39) falls rapidly, we will be dead very shortly. Mr. McCreedy should also say that 50 roentgens of whole body irradiation received in 6 minutes is much worse than 50 roentgens in 2 hours or a day, etc. The AEC considers less than 0.3 roentgens per week a "safe" working level.

Besides all that, I am dubious about a ceramic socket maintaining better than  $10^{15}$  ohms for more than a very short time, and suggest the home builder use a mica-filled socket, cutting out a notch for pin 4 and soldering a connection directly to this pin, or sliding a bushing.

TOM JASKI

San Mateo, Calif.

### TRAPPING THE RADAR DETECTOR

Dear Editor:

An item "Police Move to Outlaw Highway Radar Warning Units" appeared in March 1962 on page 6.

Muni Quip Corp. currently manufactures more radar speed meters than anyone else. Users of Muni Quip Radar have available a special circuit which shuts off the radar waves until a car which is obviously speeding is spotted. By merely flipping a switch, this circuit is energized to instantly read the speed of the approaching vehicle containing the radar detector.

This is a very effective countermeasure, and renders a radar detector useless when facing traffic police who have equipped their radar speed meter with this Muni Quip feature.

President  
Muni Quip Corp.  
Decatur, Ill.

BRUCE K. BROWN

### VIDICON FOR TV CAMERA

Dear Editor:

I have read, "Construct Your Own Low Cost TV Camera" in the May 1962 issue with great interest. Here's a tip that might be helpful to those building this TV camera.

The type 6198 vidicon tube specified has not been made for some time and is not readily obtained. To assure optimum results from what appears to be a well designed vidicon camera using minimum circuitry, it is suggested that a first-line vidicon tube (type 7038 or 7735A) be used.

These types are available from Allied Radio and other distributors and  
(Continued on page 26)

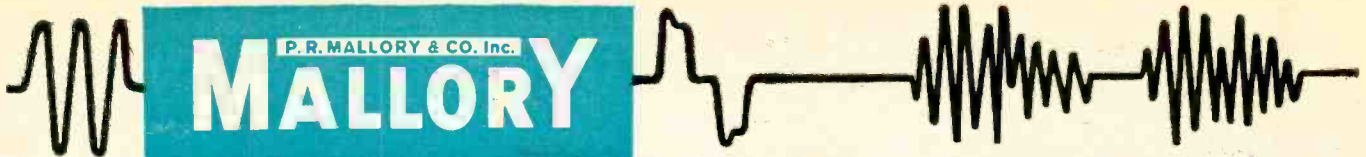

P. R. MALLORY & CO. Inc.  
**MALLORY**

## Tips for Technicians

Distributor Division, P. R. Mallory & Co. Inc.  
P. O. Box 1558, Indianapolis 6, Indiana

# Hints on Reducing Hum . . .



In high fidelity sound systems . . . and in many kinds of commercial and industrial electronic equipment . . . reduction of 60-cycle hum is one of the toughest problems that a technician has to tackle. Most hum comes from 60-cycle voltage sneaking into the signal circuit. There are, of course, many well-known precautions that should be observed . . . using shielded or coax cable between major components, keeping cables short especially in the low-level portion of the system, making sure connectors are tight. Here are some other thoughts that may be useful.

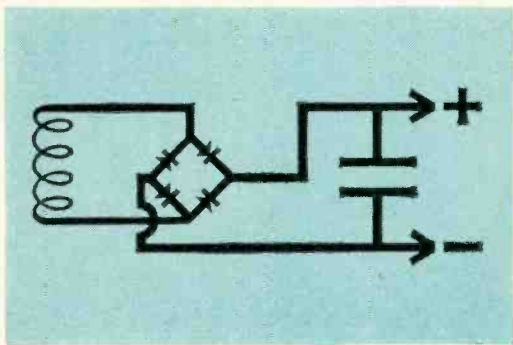

Power supplies in sound systems . . . hi-fi or commercial . . . generally operate at higher temperatures than those encountered in radio or TV. So it pays to be particular about filter capacitors. It pays to use electrolytics rated at 85° C. Those rated at only 65° C start to run into trouble. Then too, because of the added heat, the vent construction is important. In other words, "How good is the seal?" Our tip is to always use Mallory FP-WP electrolytics . . . voltage ratings are conservative and dependable . . . they have excellent stability at high temperature . . . and they all have *etched cathode* construction. This latter is extremely important in avoiding hum. We covered the reasons in a previous TIP (remember?).

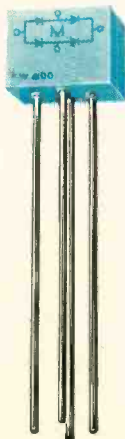

Here's another source of hum . . . filament circuits. Many of the highest quality sound systems use a DC filament supply in the preamplifier. It's easy to add this refinement to any system. All you'll need is a Mallory FW-50 "packaged" silicon rectifier circuit. It's encapsulated in a tiny plastic block and takes up very little space. Simply connect the FW-50 to the circuit, add a WP-042 electrolytic and filament hum disappears permanently. If you want more specific information, write and ask us.

Another tip: call on your Mallory Franchised Distributor for prompt service, at sensible prices, on Mallory capacitors, switches, silicon rectifiers, controls, and batteries . . . and for any other parts you may need.



# This is Sony

**THE MOST COMPLETE LINE OF QUALITY TAPE RECORDING EQUIPMENT IN THE WORLD**

■ **SONY Stereo Tape Deck 262-D**—4 & 2 track stereo recording and playback tape transport to add tape to your existing hi fi system. \$89.50. (Also available, not pictured, the new SRA-2 stereo recording amplifier for the 262 D. \$89.50.) ■ **SONY Stereorecorder 777-S**—All transistorized professional 2 & 4 track stereo recorder featuring the revolutionary Sony Electro Bi Lateral Heads. The world's finest tape recorder. \$725. ■ **SONY Stereorecorder 300**—A complete professional-quality hi fi stereo tape system with 4 & 2 track recording and playback in one portable unit. \$399.50. ■ **SONY Portable 101**—2 speed, dual-track, hi-fidelity recorder with 7" reel capacity. \$99.50. ■ **SONY Stereorecorder 464-D**—Dual performance 4 track stereo tape deck with built-in recording & playback pre-amps for custom installations and portable use. \$199.50. ■ **SONY Wireless Microphone CR-4**

—Pocket size mike and transmitter providing complete freedom from entangling microphone cables. \$250. ■ **SONY Condenser Microphone C-37 A**—For purity of sound reproduction, the unqualified choice of professional studios throughout the world. \$295. ■ **SONY Sound on Sound Recorder 262 SL**—The perfect recorder for language, music and drama students. With 4 track stereo playback. \$199.50. ■ **SONY Tape recorder 111**—A popularly priced, high quality bantam recorder for everyday family fun. \$79.50. ■ **SONY Condenser Microphone C-17 B**—Miniature size (3¼" x ½" diameter) and exceptional background isolation unidirectional cardioid pattern. \$350. ■ **SONY Newscaster Portable EM-1**—A professional on-the-spot battery powered portable recorder with precision spring wind constant speed motor. \$495. *All Sony Stereorecorders are Multiplex ready!*

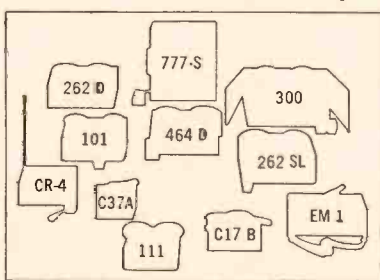

**SUPERSCOPE** The Tapeway to Stereo



# HERE'S WHY YOU SHOULD QUALIFY FOR MEMBERSHIP IN THE "PEET" PROGRAM!

JOIN THIS SELECT GROUP OF **PHOTOFACT-EQUIPPED ELECTRONIC TECHNICIANS**

ENJOY THESE EXCLUSIVE BENEFITS—NO COST TO YOU IF YOU QUALIFY!

**1**

Through your membership in the dynamic "PEET" program, you:

- Gain deserved recognition as a reputable businessman
- Acquire exceptional public trust and confidence
- Win favorable publicity, both locally and nationwide
- Earn more—"PEET" members are proving it daily

**2**

Get dynamic national advertising support

## CONTINUOUS ADVERTISING IN TV GUIDE



Powerful national advertising monthly in TV Guide now carries the "PEET" message to over 8,000,000 TV families, building dynamic support and demand for the services of "PEET" members. Now more than ever it pays to belong to the "PEET" program!

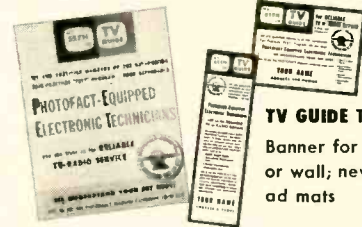

**TV GUIDE TIE-INS:**  
Banner for window or wall; newspaper ad mats

**3**

Powerful, outstanding business aids at no cost to you!

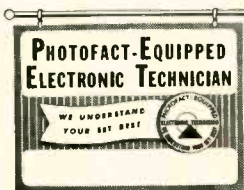

Large, full-color metal sign for outdoor display



Certificate of membership



Streamer for wall or window



Syndicated feature page display



Promotional literature, newspaper ad mats, radio & TV scripts



Helpful publicity brochure



Decals for window or truck



Cloth patch insignia



Service record stickers

**APPLY TODAY!**

### How to apply for membership in the "PEET" program

If you now own a PHOTOFACT Library, or plan to own one, you can apply at once for membership in the powerful "PEET" Program, designed to build prestige and business for the Service Technician who qualifies. Membership helps you win public respect and confidence, provably helps you *earn more*, as hundreds of "PEET" members can testify. Benefits cost you absolutely nothing if you qualify. So act now—see your distributor or use coupon at right.

**GET YOUR "PEET" APPLICATION IN NOW!**

Howard W. Sams & Co., Inc., Dept. 6-F2  
1720 E. 38th St., Indianapolis 6, Ind.

Send me "PEET" Membership Application

My Distributor is \_\_\_\_\_

Shop Name \_\_\_\_\_

Attention \_\_\_\_\_

Address \_\_\_\_\_

City \_\_\_\_\_ Zone \_\_\_\_\_ State \_\_\_\_\_

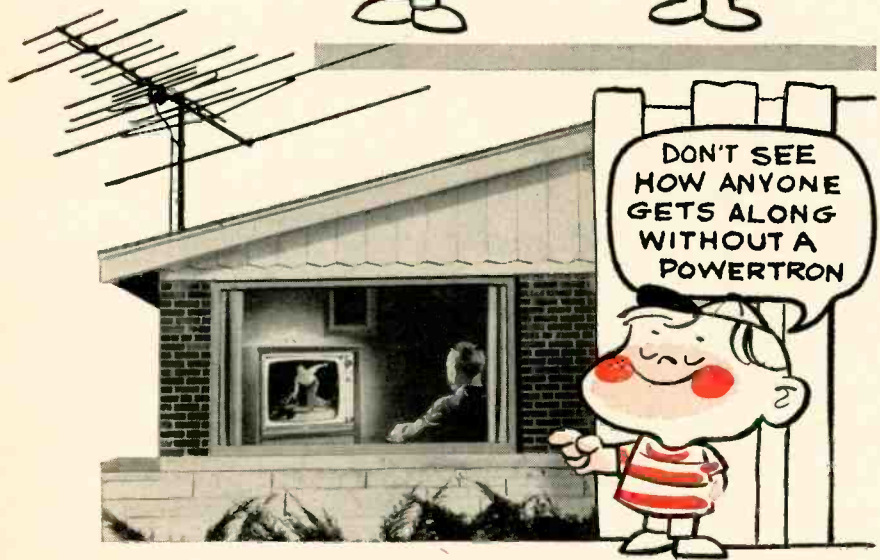
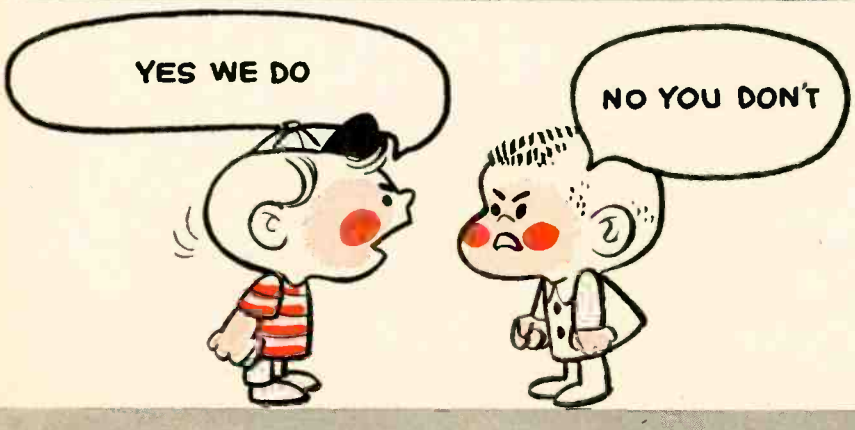
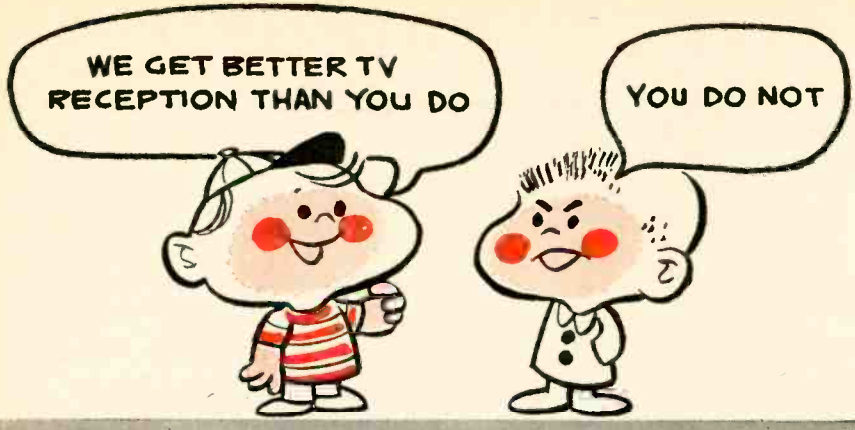

**Winegard**  
ANTENNA SYSTEMS

Winegard Co.,  
3013-6 Scotten,  
Burlington, Iowa

(Continued from page 22)  
carry the manufacturer's standard warranty and guaranty. JULIAN MCBARRON  
Closed-circuit TV field engineer  
Allied Radio Inc., Chicago

[While many readers may prefer a new tube, the article suggested surplus 6198's as part of a low-cost system, since they can be obtained at about half the cost of the new 7038's or 7735A's.]

**DON'T FORGET MALLORY!**

Dear Editor:

On page 55 of the May issue is a feature on "Replacing Japanese Transistor Radio Batteries." You listed a number of Eveready, Burgess, Ray-O-Vac and RCA equivalents of various Japanese types. But you neglected to cover any batteries made by our client, P. R. Mallory & Co. Inc.

For your information, Mallory supplies mercury, manganese and zinc-carbon batteries which will do a superior job in transistor radios. The mercury types in particular are notable for their long service, up to five times as long as zinc-carbon, and are particularly outstanding in the smaller sizes.

Here are the equivalent Mallory types for the list you published:

Size and Japanese Model	Mercury	Mallory types Manganese	Zinc-Carbon
1.5-v D cell, UM-1	RM-42	Mn-1300	M-13R
1.5-v C cell, UM-2		Mn-1400	M-14F, M-14P, M-14R
1.5-v AA cell, UM-3	ZM-9	Mn-1500	M-15R
1.5-v AAA cell, UM-4		Mn-2400	
1.5-v N cell, UM-5	RM-401	Mn-9100	M-910F
9-v 006P	TR-146	Mn-1604	M-1604
9-v W06P	TR-177		
9-v 006			M-1600

HAL M. PARSHAL

Aitkin-Kynett Co. Inc.  
Philadelphia, Pa.

**ABOUT THAT MIXER**

Dear Editor:

As always, we at Switchcraft enjoy reading each issue of your fine magazine. The February issue was no exception. One article was very interesting to our sales and engineering departments—"Spice-Can Audio Mixer."

The unusual interest was created because we have been manufacturing a miniature audio mixer, the Mini-Mix, for quite a few years.

If any readers are interested in details of this unit they can send for our Catalog A-401.

C. J. SHULTZ  
Sales Promotion Manager  
Switchcraft Inc.  
5555 N. Elston Ave., Chicago 30, Ill.

**IMPROVED SOUND INTERRUPTER**

Dear Editor:

The August 1961 issue contained an article by Elliott A. McCready titled "TV Sound Interrupter Has Only Four Parts." This circuit would work well, except for one minor detail. When the normally closed relay is opened by photocell action, the contacts place absolutely no load of any kind across the secondary of the audio output transformer. If this condition remains very

# Learn RADIO TELEVISION ELECTRONICS

## by Practicing at Home in Your Spare Time

Electronics is the outstanding career field of the 1960's. There are more better-than-average opportunities in Electronics than in any other field—openings for which you could qualify through NRI training. Thousands of men like yourself have stepped up to good money in Industrial Electronics, Radio and TV Broadcasting and Radio and TV Servicing with NRI training.

### Make More Money Soon

If you decide to be a Radio-TV Service technician, NRI training can help you step up your income soon after you enroll. We show you how to apply your knowledge to make extra cash in spare time doing Electronic repairs or servicing radios and TV sets for friends and neighbors. If desired NRI assists you in job placement when you're ready. In short, whatever branch of Electronics you select, NRI is well qualified to help you grow in your new career . . . in usefulness, in prestige, in monetary gain.

### Train With The Leader



NRI is America's oldest and largest home-study Radio-TV, Electronics training school. For nearly half a century NRI has maintained the confidence and respect of students, graduates and the Electronics Industry by constantly supplying practical, complete, up-to-date home-study training at a cost most everyone can afford. Read the capsule descriptions of NRI courses on the other side of this page. Then, mail the postage-free card today for the FREE NRI CATALOG. National Radio Institute, Washington 16, D. C.



### Equipment You Get Makes Training Faster, Easier

The NRI "train-by-doing" method, using special training equipment, is the time-proved way to assure advancement or to turn your hobby into a new and profitable career in the fast-growing field of Electronics. All NRI courses, except FCC License training, includes special equipment at *no extra cost*. You build circuits and work experiments. Theory you study comes to life in an interesting, easy-to-grasp manner. NRI catalog pictures and describes equipment you get. Mail the postage-free card for more facts about NRI training and opportunities awaiting you in Electronics, Radio-TV.

**Turn Page For Facts On NRI Courses** ➔

### Cut Out and Mail—No Stamp Needed

NATIONAL RADIO INSTITUTE  
WASHINGTON 16, D. C. RF

Please send me your Electronic, Radio-TV catalog without cost or obligation. I am interested in the course checked below. (No salesman will call. PLEASE PRINT.)

- |   |   |
|---|---|
| <input type="checkbox"/> INDUSTRIAL ELECTRONICS | <input type="checkbox"/> FCC LICENSE    |
| <input type="checkbox"/> RADIO-TV SERVICING     | <input type="checkbox"/> COMMUNICATIONS |

Name \_\_\_\_\_ Age \_\_\_\_\_

Address \_\_\_\_\_

City \_\_\_\_\_ Zone \_\_\_\_\_ State \_\_\_\_\_

ACCREDITED MEMBER NATIONAL HOME STUDY COUNCIL

Approved for Veteran's under Korean GI Bill

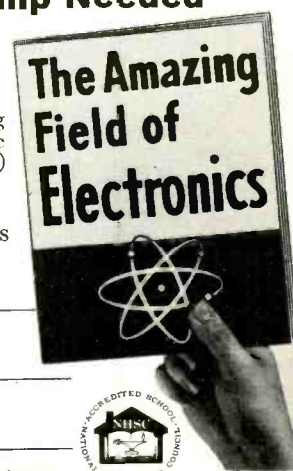

# PICK THE CAREER YOU WANT IN THE WONDERFUL FIELD OF ELECTRONICS TRAIN AT HOME WITH THE LEADER

## INDUSTRIAL ELECTRONICS



Prepare for a career as an Electronic Technician in industry, business, government, the military, with this NRI course in Electronics—Principles, Practices, Maintenance. Computers, telemetry, automation, missiles, rockets all employ the same basic principles . . . and that is what this NRI course stresses with illustrated lessons, special training equipment.

## TELEVISION-RADIO SERVICING (INCLUDES COLOR TV)



NRI's time-tested course in Servicing not only trains you to fix radios, TV sets, hi-fi, etc., but also shows you how to earn spare-time money starting soon after enrolling. Fast growth in number of sets, color-TV, stereo, means money-making opportunities in your own spare-time or full-time business or working for someone else. Special training equipment included.

## TV-RADIO COMMUNICATIONS



In the NRI Communications course you get *actual experience* as NRI prepares you for your choice of Communications fields and an FCC License. Commercial methods and techniques of Radio and TV Broadcasting; teletype; facsimile; microwave; radar; mobile and marine radio; navigation devices; FM stereo multiplexing are some of the subjects covered. You work with special training equipment.

## FCC COMMERCIAL LICENSE



For men with Radio-TV experience who want to operate or service transmitting equipment used in broadcasting, aviation, marine, microwave, facsimile or mobile communications. A Service Technician is *required by law* to have an FCC License to work on C-Band, other transmitting equipment. From Simple Circuits to Broadcast Operation, this new NRI course trains you quickly for your Government exams.

← SEE OTHER SIDE →

## Job Counselors Recommend

Today, a career in Electronics offers unlimited opportunity. Job counselors advise, "For an interesting career, get into Electronics." The National Association of Manufacturers says, "There is no more interesting and challenging occupation in American industry."

When you train for a career in Electronics through NRI home-study methods your home becomes your classroom, and you the only student. You pick your own study hours, study when you want, as long as you want. No need to give up your job or go away to school. And there are no special requirements of previous Electronics experience or education. Train with the leader. Your NRI training is backed by nearly 50 years of success. Mail the postage-free card. **National Radio Institute, Washington 16, D.C.**

FIRST CLASS  
PERMIT  
NO. 20-R  
(Sec. 34.9, P.L.&R.)  
Washington, D.C.

**BUSINESS REPLY MAIL**  
NO POSTAGE STAMP NECESSARY IF MAILED IN THE UNITED STATES

POSTAGE WILL BE PAID BY



**National Radio Institute**  
3939 Wisconsin Avenue  
Washington 16, D.C.



← Mail Postage-Free Card

long, the transformer may burn up.

I have studied the circuit closely and found a way out of this trouble. Fig. 1 is a diagram of your circuit. My addition calls for a relay with two sets of contacts—one set normally closed, and the other normally open. When the relay is triggered by the action of the photocell, the normally open contacts close and shunt a low-value resistor across the output transformer to pre-

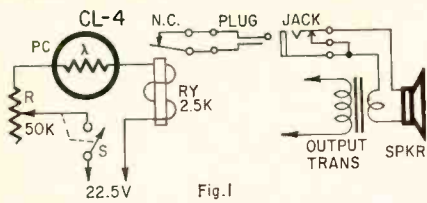

Fig. 1

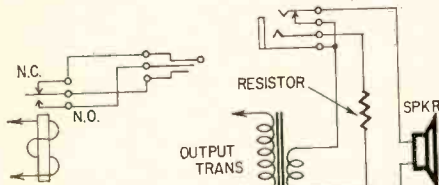

Fig. 2

vent any damage to the output tube or other components associated in the circuit. The normally closed contacts act as before.

ROBERT BAKER

Detroit, Mich.

[The length of a commercial should not be long enough to damage the equipment. However, some circuits are more susceptible to this trouble than others.

The relay specified (Sigma 5F-2500-S/SIL) has double-throw contacts so you don't need a new relay with double-pole contacts (Fig. 2). Use a 3-conductor plug and 3-conductor, closed-circuit jack between the relay and receiver. The arm of the relay goes to the top end of the transformer secondary and the normally closed contact goes to the top end of the voice coil. The normally open contact connects to the other end of the secondary and voice coil through the resistor.—*Editor*]

### HALF-POCKET RADIO TOO BIG

Dear Editor:

I recently built the Tax radio described in the March 1962 issue. Performance was excellent, but I have been able to cut its size in half and retain almost the same performance.

The following changes were made:

For a pot I used a Lafayette VC61. It is mounted outside the case.

I replaced the variable capacitor with a transistor socket. Then I determined the value of a capacitor which would pick up my favorite station, and plugged it in.

Several capacitors for desired stations can be made up and marked with the letters of the station. JOSEPH DINI  
Boston, Mass.

[Congratulations! There is certainly nothing wrong with this approach. It is probably especially useful in areas where there are only one or two stations. Guess you now have a quarter-pocket radio.—*Editor*] END

Precision performance  
is your passport to  
the amazing world of  
short-wave listening



**hallicrafters**

5th and Kostner Avenues, Chicago 24, Illinois

"world-range" radio

S-119K Sky Buddy Receiver Kit—\$39.95.  
S-119 (factory wired and tested) \$49.95.  
Standard broadcast. Two short wave  
bands (2-5.5 Mc. and 5.7-16.4 Mc.). Su-  
perheterodyne circuit. Transformer-type  
power supply.



SX-62A Receiver—\$395.00. Standard and  
FM broadcast. Three short wave bands  
(1.62 Mc-109 Mc). Excellent audio. Slide  
rule dial. Single tuning control. Auto-  
matic noise limiter. Uses R-48 speaker.  
(\$19.95)

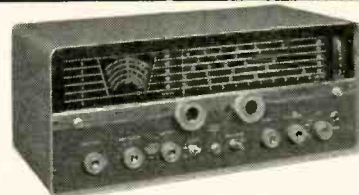

SX-110 Receiver—\$169.95. Standard broadcast.  
Three short wave bands (1550 kc-34 Mc). Slide  
rule electrical bandspread dial. Built-in "S" me-  
ter, antenna trimmer, crystal filter. Uses R-48  
speaker (\$19.95).

S-120 Receiver—Standard broadcast  
plus three short wave bands (1650 kc-31  
Mc). Three-way antenna system. Slide  
rule electrical bandspread dial. B.F.O./  
selectivity control.

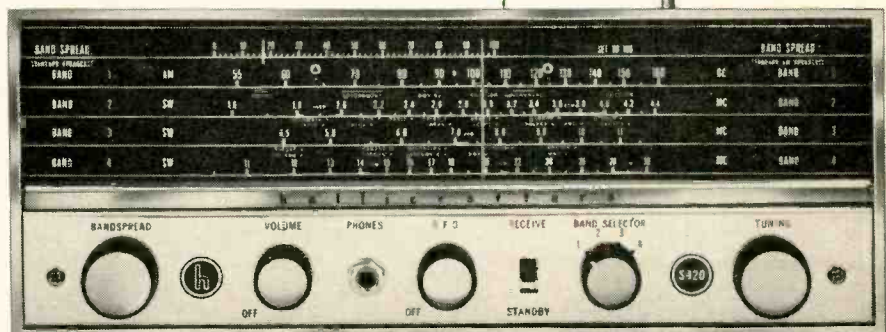

Export Sales: International Division, Raytheon Mfg. Co., Waltham, Mass. Canada: Gould Sales Co., Montreal, P. Q.

DON'T  
MISS THESE  
COMING  
FEATURES IN

- Electronic Ignition for Your Car
- Servicing Those Color Circuits
- Highway Radar Nabs Speeders
- Detecting Atomic Radiation
- Build a Random Noise Generator
- Professional Quality Preamp and Control Center
- Increase Your Multimeter Sensitivity
- Build an All-Transistor Hi-Fi Amplifier
- Hi-Fi FM Reception in Fringe Areas

SUBSCRIPTION RATES

1 Year \$5      2 Years \$9      3 Years \$12

**Radio-Electronics**

154 West 14th Street  
New York 11, N.Y.

# EICO®...UNCOMPROMISING ENGINEERING

**BEST BUYS IN SERVICE INSTRUMENTS:** everything from Scopes to Probes



**DC-5 MC**  
5" Scope #460  
Kit \$79.95  
Wired \$129.50  
Also Avail.—5" Push-Pull Scope #425  
Kit \$44.95 Wired \$79.95



**Peak-To-Peak VTVM #232**  
& Uni-Probe®  
Kit \$29.95  
Wired \$49.95  
VTVM #221  
Kit \$25.95  
Wired \$39.95

†Pat. #2,790,051



**Dynamic Conductance Tube & Transistor Tester #666**  
Kit \$69.95 Wired \$109.95  
Complete with steel cover & handle



**TV-FM Sweep Generator & Marker #368**  
Kit \$69.95 Wired \$119.95

**BEST BUYS FOR INDUSTRIAL TESTING:** everything from Bridges to Supplies

**NEW Metered Variable Auto-Transformer AC Bench Supplies:**  
#1073 (3 amp.)  
Kit \$35.95  
Wired \$47.95  
#1078 (7½ amp.)  
Kit \$42.95  
Wired \$54.95



**NEW Extra-Low-Ripple 6 & 12 Volt Battery Eliminator & Charger #1064**  
Kit \$43.95  
Wired \$52.95



**NEW AC Volt-Watt Meter #260**  
Kit \$49.95  
Wired \$79.95



**1350 Combinations! Series/Parallel R-C Combination Box #1140**  
U.S. Pat. No. 2954518  
Kit \$13.95 Wired \$19.95



**BEST BUYS IN STEREO & MONO HI-FI:** everything from Tape Decks to Speakers

**Transistorized Stereo/Mono 4-Track Tape Deck**  
Wired Model  
RP100W  
\$399.95  
Semi-Kit Model  
RP100K  
Electronics in Kit form \$299.95



An original, exclusive EICO product designed and manufactured in the U.S.A. (Patents Pending)

**NEW FM-Multiplex Autodaptor MK99**  
Kit \$38.95 Wired \$64.95  
Cover optional, \$2.95  
Designed for all EICO FM equipment (HT90, HT92, ST96) and any other component quality, wide-band FM tuner.



**NEW 70-Watt Integrated Stereo Amplifier ST70**  
Kit \$94.95 Wired \$149.95



**NEW FM-AM Stereo Tuner ST96**  
Kit \$89.95 Wired \$129.95 Inc. FET

**NEW 40-Watt Integrated Stereo Amplifier ST40**  
Kit \$79.95 Wired \$129.95



**Bookshelf Speaker System HFS1**  
Kit \$39.95 Wired \$47.95

**BEST BUYS IN "HAM" GEAR:** from Transmitters to Code Oscillators



**NEW 60-Watt CW Transmitter #723**  
Kit \$49.95 Wired \$79.95



**90-Watt CW Transmitter #720**  
U.S. Pat. No. D-184776  
Kit \$79.95 Wired \$119.95



**Universal Modulator Driver #730**  
Kit \$49.95 Wired \$79.95  
Cover E-5 \$4.50



**Grid Dip Meter #710**  
Kit \$29.95 Wired \$49.95

Over 2 MILLION EICO instruments in use. Compare EICO side-by-side critically with products selling for 2 or 3 times more. Buy your EICO right "off the shelf" from 2000 neighborhood dealers coast to coast, most of whom offer budget terms.

**BEST BUYS IN CITIZENS TRANSCEIVERS AND TRANSISTOR RADIOS**

Over 106 unique products to choose from!



EICO, 3300 N. Blvd., L.I.C. 1, N.Y. C-6

- Send free 32-page catalog & Distributor's name.
- Send Free Schematic of Model No.
- Send new 36-page GUIDEBOOK TO HI-FI for which I enclose 25c for postage & handling.

Name.....  
Address.....  
City..... Zone .. State.....



**Citizens Band Transceivers**  
From: Kit \$59.95 Wired \$89.95  
Superhet; prealigned xmitter osc; match different antennas by variable "pi" network. Single & multi-channel models.



**NEW Walkie-Talkie Citizens Band Transceiver #740**  
Kit \$54.95. Wired \$79.95.  
Carrying Case \$3.95.  
Complete with rechargeable leakproof battery & charger. Operates 2500 hours on the battery. U. S.-made by EICO.



**Transistor Portable Radio RA6**  
Kit \$29.95 Incl. FET

Listen to the EICO Hour, WABC-FM, N. Y. 95.5 MC, Mon.-Fri., 7:15-8 P.M. Add 5% in the West © 1962 EICO Electronic Instrument Co. Inc., 3300 N. Blvd., L.I.C.1, N.Y.

# EARTH SIGNALS ON THE MOON

... Coming Communications Problems Between Earth and Moon ...

**W**ITHIN the next few years—certainly before 1970—men will have landed on the moon, opening up a vast new world.

However, before humans actually visit the moon, they will have been preceded by electronically equipped robots, specifically designed to pre-explore the moon's inhospitable environment. Many moon-landing vehicles and machines already have been designed, and prototypes built. These robot explorers will make "soft" landings on the lunar surface, after having been propelled by rocket over the 238,000 miles separating the moon from earth. Guided entirely by electronics and telemetric control, not every one of the early lunar flights can be expected to turn out smoothly. There probably will be mislandings—not all moonshots will be successful, any more than all our first earth satellites succeeded. But we may be certain that before 1970 we will have succeeded in setting down a number of lunar robots that will make later manned landings reasonably safe.

One of the difficult problems in *precise* moon landings—possibly solved theoretically by now—is the time lag of telemetering the robots from earth. It takes 1.2 seconds for light or radio waves to span the 238,000 miles between earth and moon in one direction. Even if you could follow a rocket's flight to the moon via telescope, it would be impossible actually to see the last *important* 50 or so feet of the descent. Because light from the moon takes 1.2 seconds to reach the earth observer, he of course could not see the approach to landing till 1.2 seconds *later*. It would therefore be a most difficult operation to land a rocket robot telemetrically from earth.

There are, however, better and more precise means to soft-land lunar robots. Let us mention only one. The principles we used during World War II in the electronically operated proximity fuze—or similar ones—can conceivably operate the robot's retro-rockets, independent of earth telemetry. These means will be certain and automatic for all landing purposes. Once the robot equipment has arrived safely and intact on the moon, earth scientists can take over certain operations via telemetry. Because, in all likelihood, the robot must be able to move over small distances for orientation and exploring purposes, it will be equipped with a TV camera so that earth observers can see the machine's immediate environment. Other vital information sent via radio for the benefit of physicists, geologists and astronomers would be transmitted automatically by the robot's exploratory instruments.

While we have made innumerable radio contacts with the moon since 1946,\* bouncing signals off its

surface successfully, there will be some future problems which cannot be solved with certainty until we actually get to the moon.

Because lunar robot receivers must of necessity be exceedingly sensitive, interference from earth transmitters to the special moon-beamed signals intended to operate the moon robots will become critical.

Consider that the moon always turns its same side to the earth. It is known today that *all* frequencies (even broadcast waves) penetrate our atmosphere to a certain degree. But frequencies, from the vhf range down to centimeter waves, probably reach the moon in various intensities from earth transmitters "visible" to the moon. As the earth turns, many earth transmitters will contact the moon once in 24 hours.

Note also the inevitable Doppler effect of the rapidly spinning earth—1,000 miles an hour at the Equator—when it transmits vital signals to a moon robot. This complicates reception.

Earth signals will come in strongest on the moon robot's instruments when the earth station is exactly opposite to it. They will become progressively weaker as the earth transmitter nears a 90° angle *vis-à-vis* the receiver on the moon. This is because the radio waves now must pierce the vast horizontal mass of the earth's atmosphere, against the former 150 miles or so when the moon is overhead. To circumvent this, we require a number of transmitters located at different points on the earth, all connected in a radio network, if we intend to maintain 24-hour uninterrupted communication with moon robots.

Another completely unsolved problem is future radio communication on the moon. Because of its small diameter, the moon's horizon is much nearer than that on earth. The moon having no Heaviside layer, radio communication can reach only as far as the horizon, some 2 miles, if the transmitter and receiver are 10 feet above the ground.† We know nothing of the ground composition of the moon—whether it is conductive or not. Hence we cannot know until we get to it if we can communicate through ground-wave conduction as we do on earth. If we can, the problem of radioing to any distance and to the far side of the moon will become simple and inexpensive. If not, we must set up a cumbersome and expensive radio relay system.

—H.G.

\*The author first predicted echo radio signals from the moon in his former magazine, *Radio News*, in the article "Can We Radio the Planets?" in the February, 1927 issue. In January, 1946, the US Signal Corps first established two-way radio contact with the moon in 2.4 seconds, as predicted by the author 19 years before. (His forecast time had been 2.5 seconds, an error of 1/10 second.)

†See also "Radio On the Moon," *Radio-Electronics* July, 1959, and "Lunar Radio and TV Traffic," December, 1961.

# Check Auto Ignition

with an

# Ohm-Dwell Tachometer

*Three-way instrument is a must when  
you tune up your car. Easy to build and use.*

By ALEX M. SCHOTZ\*

When servicing a modern automotive engine, we must be able to measure point dwell time, point resistance and engine rpm. This article describes a home-built single instrument that will do these three things.

Most dwell meters indicate how long the breaker points are closed before they open when the engine is running. They measure the percentage closed-contact time in relation to the total open and closed period. This indication is converted to degrees on the meter scale.

Converting these percentages to degrees depends on the number of lobes on the cam operating the points. The number of lobes divided by  $360^\circ$  gives you the number of cylinders. It is simple

\*Outboard Marine Research Center, Milwaukee, Wis.

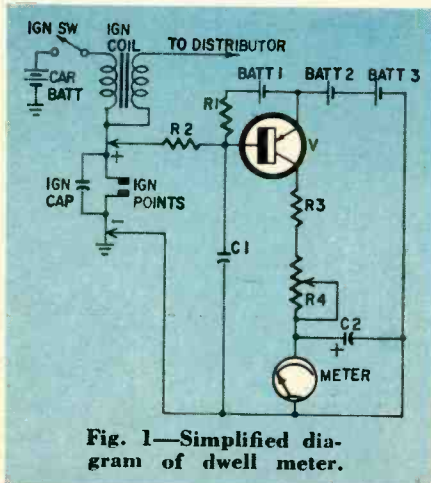

Fig. 1—Simplified diagram of dwell meter.

to convert the percentage dwell time to degrees—a four-cylinder engine has four lobes:  $360^\circ$  divided by 4 equals  $90^\circ$ , and four divided by  $360^\circ$  equals 1.1% per degree. For six cylinders, we get  $60^\circ$  or 1.66% per degree. For eight cylinders, we get  $45^\circ$  or 2.2% per degree.

Generally, dwell meters are set up so that, when the breaker points are closed, current passes through a meter (previously adjusted to indicate full scale), and, when the points are open, the meter reads zero. When the engine is running, the action is very rapid, and the meter needle does not have time to read either full scale or zero. Instead, it assumes a position equivalent to the average period that the contacts are closed.

Fig. 1 is a simplified diagram of the dwell meter used in the ohm-dwell-tachometer described in this article. The input leads are attached across the breaker points. They must match the ignition polarity. With the engine at rest and the breaker points fully closed, V is forward-biased through R2. This in turn causes V to conduct fully, and V then acts as a closed switch. Now R4 is adjusted so the meter reads full scale.

Then the auto engine is started and revved up to the proper rpm. Every time the breaker points open, V is cut off because it is reverse-biased by BATT 1 through R1. This stops the flow of current through the meter. The meter indicates the average closed time of the breaker points, as previously described.

C1 and R2 form a low-pass filter which bypasses the high-frequency pulses that occur when the breaker

points open. R3 is a current-limiting resistor. It protects the meter against too much current flow caused by mis-adjusting R4. Capacitor C2, in parallel with the meter, provides electrical damping to prevent it from oscillating. The greater the capacitance, the slower the reaction time of the meter. If the input leads are reversed, the meter will give the wrong indication, because, when the points are open, the car battery's potential will forward-bias V.

When adjusting, installing or checking ignition points, a low-resistance ohmmeter is very handy.

The instrument should be able to indicate down to 0.1 ohm. To do so simply, a shunt type ohmmeter circuit is necessary (Fig. 2). The meter should have either a low internal resistance or a low-resistance shunt in parallel with a high-resistance meter. As a general rule, low-internal-resistance meters are the higher-current type.

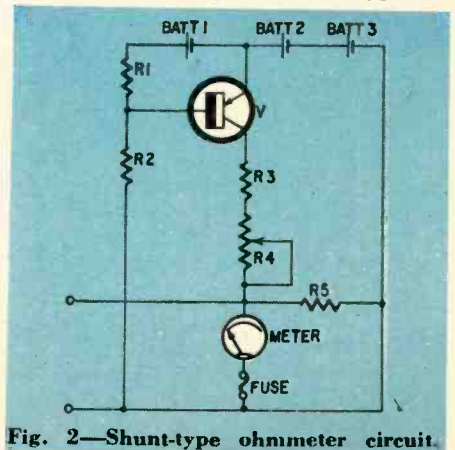

Fig. 2—Shunt-type ohmmeter circuit.



Two practical limits govern meter selection for this application—the current drain on the activator and the fact that the meter has to serve as a tachometer. We used a sensitive meter and the appropriate shunt (R5).

In this circuit (Fig. 2), V is forward-biased through R2, forcing it to conduct fully. R4 is adjusted so the meter needle is at full scale. When the two input leads are shorted, zero current goes through the meter and the needle returns to its relaxed position, indicating zero resistance.

### Meter calibration

To calibrate the meter scale you'll need a low-resistance decade box with accurate resistors or have to know the meter's effective internal resistance.

With a resistance decade box, the scale can be marked off by connecting the meter's input leads across the decade-box terminals. The desired points are set on the box and then marked on the meter face at the point where the needle comes to rest.

If a decade box is not available, accurate resistance values can be calculated with the formula:

$$R_x = \frac{R_m}{\left(\frac{M_i}{m_i}\right) - 1}$$

where  $R_x$  is the resistance to be measured in ohms and  $R_m$  is the internal resistance of meter. (When a shunt is used, this must be taken into account and thus the effective internal resistance value is the combination of both shunt and meter resistance in accordance with Ohm's law.) Also  $M_i$  is the full-scale range of meter in ma. (This

is the effective value and once again if a shunt is used, this must be taken into account.) And  $m_i$  is the meter reading in ma when  $R_x$  is connected to the input terminals.

The formula can be rearranged so that meter readings are predicted with different values of resistance:

$$m_i = \frac{R_x M_i}{R_m + R_x}$$

The meter I selected has a 0–1-ma movement and its internal resistance is 40 ohms. To measure resistances smaller than 0.1 ohm, a shunt ( $R_s$ ) was selected to increase the current to 5 ma. The shunt's value was calculated by the formula:

$$R_s = \frac{R_m}{N - 1}$$

where  $R_s$  is the shunt value in ohms;

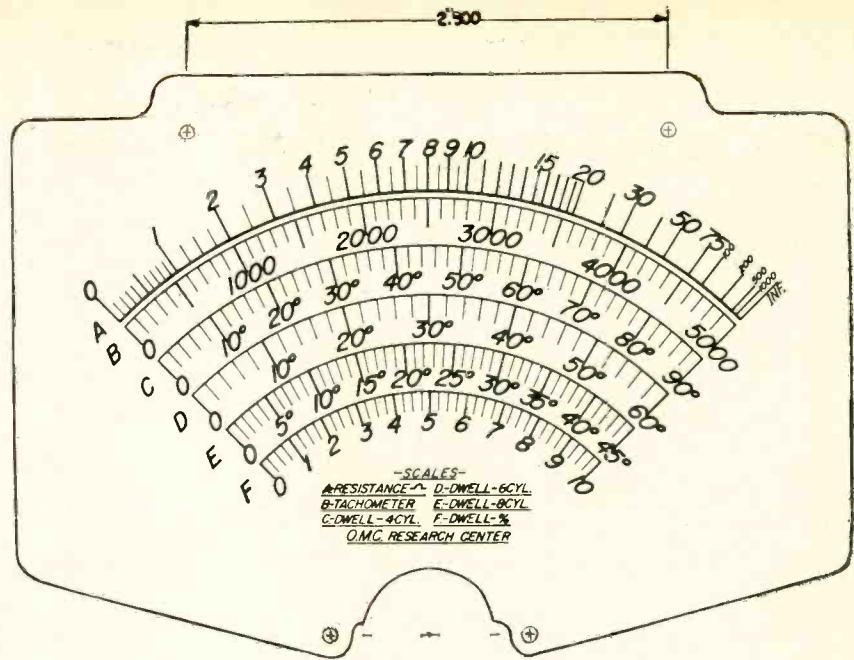

Actual size meter dial if you use the model 29 meter. It will be accurate to within 2 or 3%.

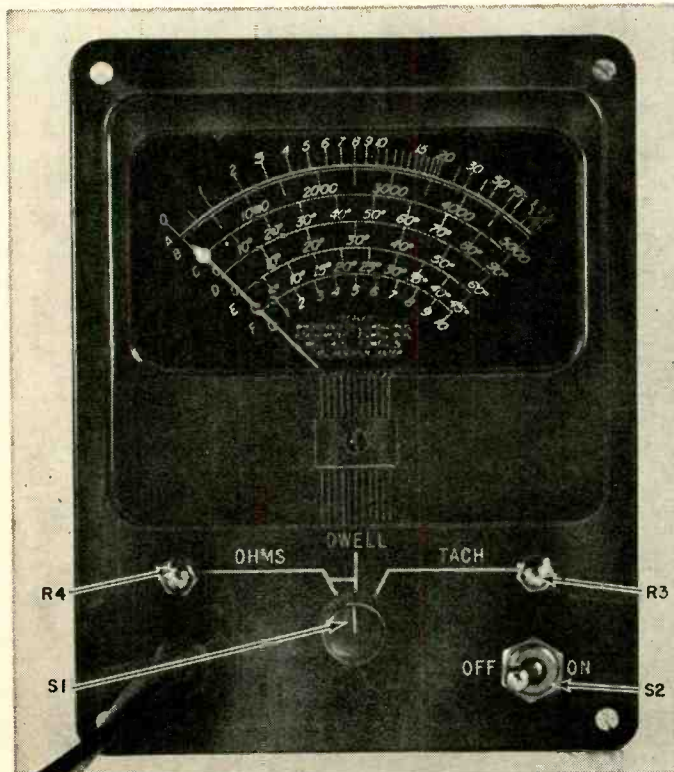

Front-panel view of the completed unit.

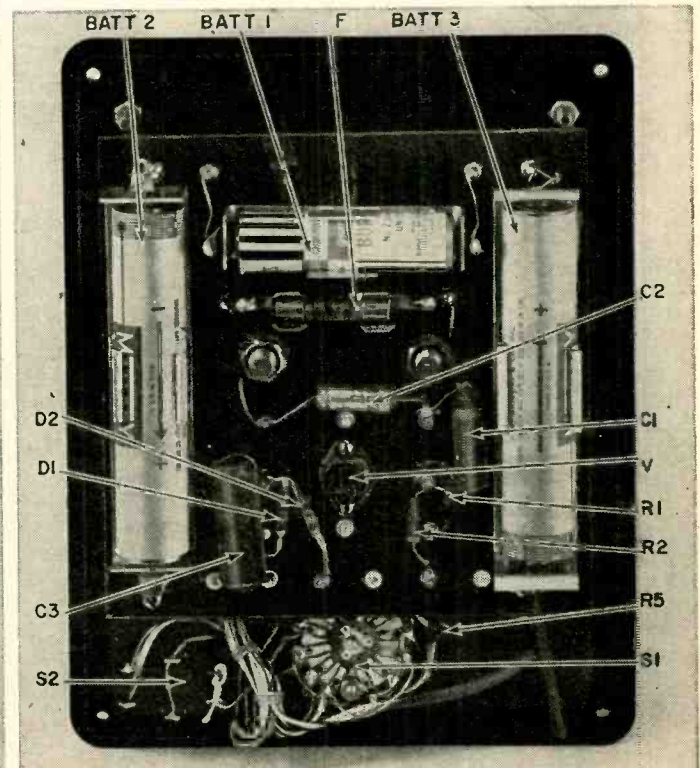

Inside the case. Note how most components are mounted on a phenolic board mounted on meter terminals.

N is the selected full-scale reading divided by the original full-scale reading, and Rm is the meter resistance in ohms.

Inserting the known values, the shunt's resistance is:

$$R_s = \frac{40}{\left(\frac{5}{1}\right) - 1} = 10\Omega$$

With the 10-ohm shunt, the current rating was increased to 5 ma and the effective internal resistance became 8 ohms. With these values set, 10 resistance points to be indicated on the meter dial were chosen. By inserting each of these resistances in the stated formula it was possible to mark these points on the meter face. The resistance points chosen and their matching currents on the 0-5-ma scale are shown in the chart below, with the percent of indication of full scale:

0.1 ohm =	.0618 ma	1.23 %
0.5 ohm =	.294 ma	5.88
1.0 ohm =	.552 ma	11.04
1.5 ohm =	.788 ma	15.76
2.0 ohm =	1.00 ma	20.00
5.0 ohm =	1.92 ma	38.4
10.0 ohm =	2.78 ma	55.6
20.0 ohm =	3.58 ma	71.6
50.0 ohm =	4.33 ma	86.67
100.0 ohm =	4.60 ma	92.0

By interpolation more points were indicated.

### The tachometer

Many ignition technicians either have a tachometer or advocate the use of a dwell meter simultaneously with a tachometer. Those who would like to construct their own ohm-dwell meter will find a simple and foolproof circuit in Fig. 3. The schematic shows where external terminals can be brought out to replace the 13-volt internal battery supply. They can be connected to the 12-volt automotive battery.

The tachometer range designed to be used with the ohm-dwell meter indicates 0-5,000 rpm and can be applied to 4-, 6- or 8-cylinder 4-cycle battery ignitions, or 2- or 4-cylinder 2-cycle ignitions. It counts the number of ignition point closings.

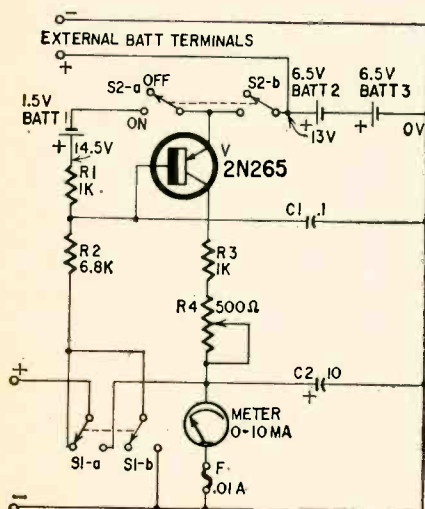

Fig. 3—Ohm-dwell meter circuit for the man who already has a tachometer.

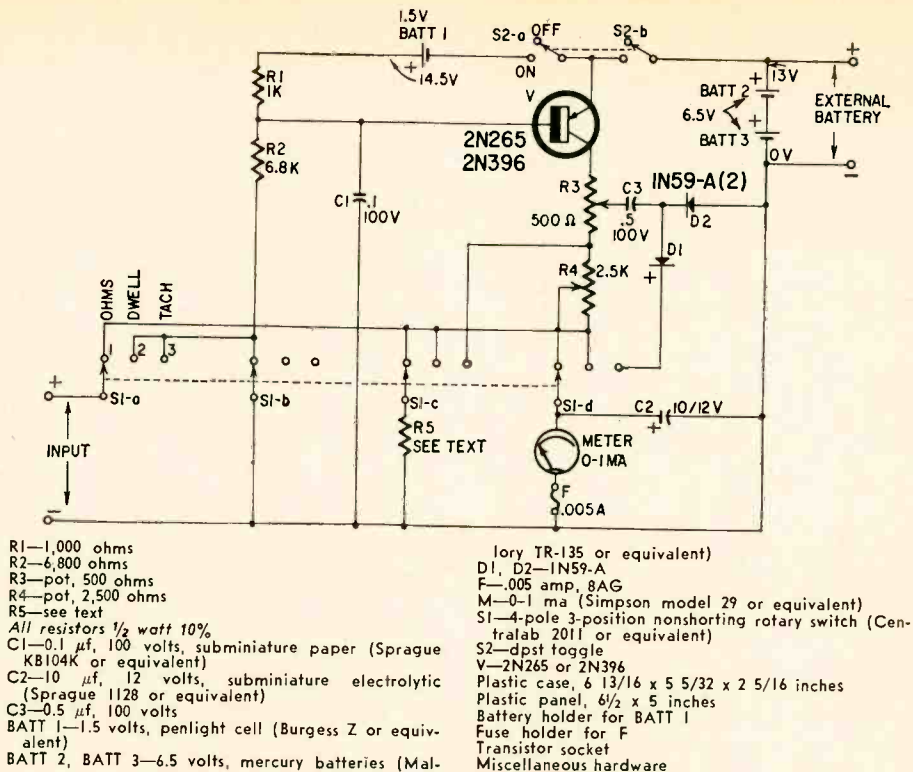

Fig. 4—Complete circuit of the ohm-dwell tachometer.

Breaker points are interrupted at every other revolution per cylinder on a 4-cycle engine, and at every revolution per cylinder on a 2-cycle engine. This means that on a 4-cylinder 4-cycle engine there are two interruptions per revolution, and on a 4-cylinder 2-cycle engine there are four interruptions per revolution.

Fig. 4 is the complete circuit of the combination ohm-dwell tachometer. When S1 is turned to TACH and the input attached across the breaker points with the proper polarity, V1 conducts every time the points are closed and is cut off when they are open. This puts the potential of BATT2 and BATT3 across calibrating potentiometer R3 with each ignition point closing. In essence, a pulse whose magnitude is equal to the voltage of BATT2 plus BATT3 is produced with each make and break of the ignition points. These pulses charge C3 through the meter and D1. When V is cut off, the charge on C3 leaks off through D2, thus pulsing the meter every time V1 conducts. The amount of current the meter will indicate is a function of the charging voltage multiplied by the frequency of the pulses per second. This in turn is multiplied by the size of the capacitance. If the capacitance is in microfarads, the current will be in microamps:

$$I = EFC$$

when I = current, E = voltage, F = frequency, C = capacitance.

There are limitations to the size of capacitance for this type diode pump circuit. The charging current supply should be at least 10 times the maximum the meter will have to indicate. For this reason, R4 is switched out of the tachometer circuit. To calibrate the tachometer, apply the secondary of a 12-volt filament transformer to the in-

put and adjust R3 so the meter indicates the proper rpm for the number of point interruptions per rpm as indicated in the chart:

Points closed per rpm	Adjust meter to read	4-cycle engine
2	1,800	4 Cylinders
3	1,200	6 Cylinders
4	900	8 Cylinders

Layout and wiring are not critical and are left to the discretion of the builder. With a few additions and modifications, this instrument could measure voltage and the ohmmeter range could be extended. Switching out the meter shunt in the ohmmeter circuit extends the range approximately five times. However, the scales will not coincide. Charts can be prepared for cross reference with the information supplied here if redrawing all or some of the scales on the meter face is not desired.

The accuracy of any instrument depends on the components used and the accuracy of the calibration method. For example, if meter accuracy is 3% of full scale, the linear response obviously can deviate as much. When it is possible to calibrate the meter at different settings of the indicating needle with an accurate transducing source, do so.

Switching from the tachometer to the dwell circuit, or vice versa, is arranged so it can be done while the engine is operating, without damaging the meter or any of the components.

Since the input impedance of the dwell tachometer is greater than 7,000 ohms, there is practically no loading effect on the ignition. When the dwell-tachometer is operated on its own power supply, this instrument will operate on all ignition voltages up through 24.

END

# What About the Bias Oscillator?

The part it plays in tape recording

By EARL E. SNADER\*

A little time spent examining the tape recorder bias oscillator, to get a clear picture of why it is needed and how it can be serviced, should be worth while to the technician. This article describes what the bias oscillator does in the recording process, gives reasons for differences in impedances and other characteristics, and briefly, effects on output caused by too much or too little bias.

A second article will describe a number of bias circuits as used in commercial machines, and a third will be devoted to servicing bias oscillators.

A tape recorder is expected to make a recording on a tape that can be sensed by a reproducing system and changed back into sound as nearly like the original as possible.

In a magnetic tape recorder this is done by using a tape coated with fine iron particles. The recording head is an electromagnet which has been connected to the output of an audio amplifier. As the tape moves past this electromagnet, at a carefully controlled speed, each iron particle on the tape retains the magnetism that is induced when the flux from the head passes through it.

The coils of the record head are wound on a metal core specially designed to follow the varying magnetic field produced by the audio current from the recording amplifier flowing through the coils, and to concentrate this field at the particular point where the record head is in contact with the tape.

## Tape recorder head gaps

There is a gap in the core of the record head where the tape touches the head. The magnetic flux in the core of the record head passes through the magnetic coating on the tape across this gap.

The width of the gap has an important bearing on tape head operation. A recording head must have a gap just wide enough to permit enough flux to penetrate the coating on the tape to leave the iron particles in a magnetized condition. Gap widths from 150 to 300 micro-inches are common.

The structure of a tape playback head is very similar to that of a recording head, except that the coils may have more turns (for greater output), and the gap may be smaller. A tape play-

\*Customer service, Viking of Minneapolis.

back head often has a narrower gap so it can reproduce higher frequencies. The gap on a tape head gets wider as the head wears. One of the most common symptoms of a worn head is a noticeable drop in high-frequency response.

Gaps as small as 90 micro-inches are used in playback heads for slow tape speeds. Gap widths of around 150 micro-inches are common on machines that have been designed primarily for playback at a tape speed of 7½ inches per second. If the tape is run at higher speeds, 15 or 30 ips, the gap width of the playback head can be made larger without sacrificing high-frequency response.

Fig. 1 shows how the magnetic flux is concentrated around the gap so it can penetrate the coating of iron particles on the tape.

Up to this point, it would appear that magnetic tape recording is a very simple process, requiring nothing more than a suitable mechanism for moving tape past a recording head that has been connected to the output of an audio amplifier.

Actually it doesn't work out this way, because magnetic tape is a nonlinear recording medium. The differences in the magnetic pattern that is transferred to the tape do not correspond exactly with the differences in the magnetic flux that caused them. The amount of

permanent magnetization that remains in the iron particles as a result of the flux from the recording head can be plotted on the hysteresis curve for a given type of particles and coating.

If nothing more than an audio signal is used to energize the electromagnetic recording head, the resulting magnetic pattern on the tape will never be exactly the same as the magnetic fluctuations that produced it. Such a recording will be distorted when it is played back.

A low distortion level is not important in some applications. But it is important in audio recording, and something must be done to make the magnetic pattern on the tape suitable for playback so the listener will hear an accurate reproduction of the original.

## Bias plays its part

This is where bias comes in. If a direct or alternating current of the right magnitude is passed through the record head coils along with the audio signal from the recording amplifier, a magnetic pattern that will not reproduce as a badly distorted signal can be placed on the tape.

A common method of biasing the record head is to superimpose an alternating current on the audio current that is fed to it. The alternating current is at some ultrasonic frequency, and its amplitude may be as much as 10 times

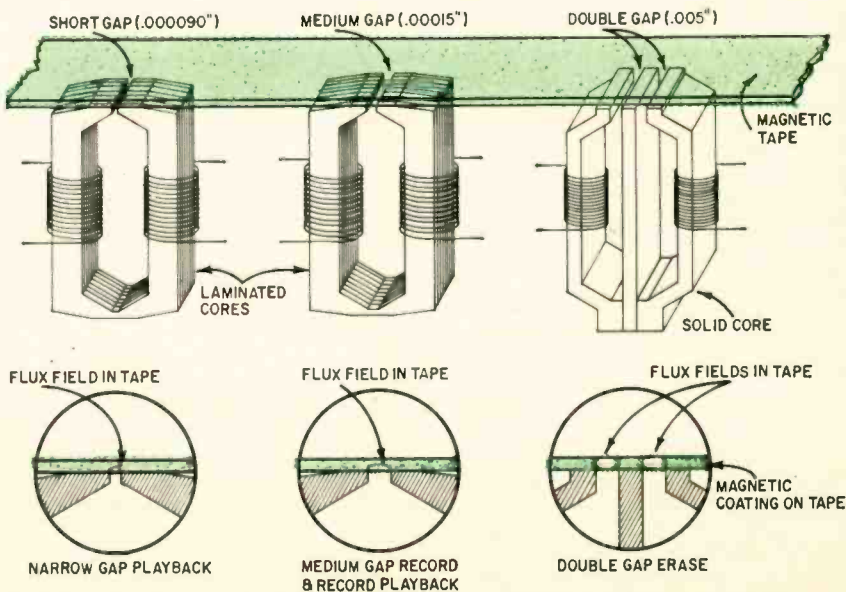
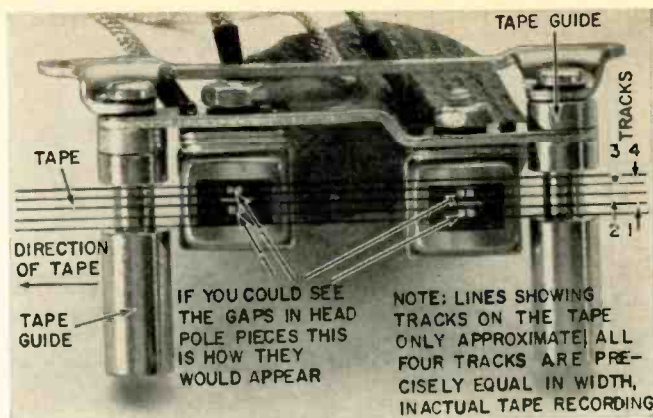
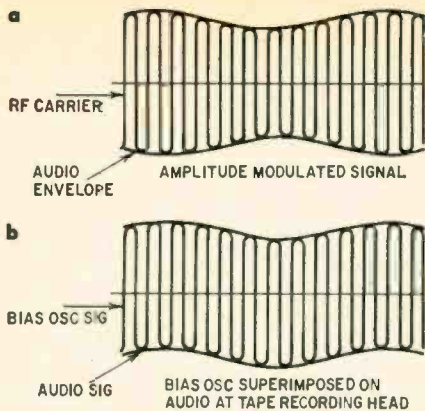

Fig. 1—Cross-section views show effect of gap length on flux field.





**Fig. 2—The difference between an AM signal (a) and the composite signal at a magnetic tape recording head (b).**

the average amplitude of the audio signal. This alternating current is generated by a fairly stable oscillator, set to operate at about 30 kc in some tape recorders or as high as 100 kc in others.

When ac at an ultrasonic frequency biases a record head, it causes each iron particle on the tape to go through a number of complete hysteresis loops as it passes the gap. The particular magnetized condition that has been induced in each particle will then remain according to the magnitude and frequency of the audio signal (on which the bias signal has been superimposed) at the moment the particle leaves the gap. This leaves a magnetic pattern on the tape that can be played back to reproduce a fairly accurate copy of the original audio signal.

It is important to note that the

alternating bias current is superimposed on the audio signal from the recording amplifier. The amplitude of this current remains constant. It is not modulated by the audio signal from the recording amplifier. If the combined audio and bias signal is viewed on a scope, the bias signal will appear to be riding on the waveform of the audio signal. The difference between an amplitude-modulated signal and the composite signal at a magnetic tape recording head is shown in Fig. 2.

### Factors affecting recording

A number of variable factors affect recording. The ratio, already mentioned, between the amplitude of the audio signal and the bias signal is important in determining the quality of a magnetic tape recording. The electrical and mechanical characteristics of the record head, the characteristics of the magnetic coating on the tape, the bias oscillator frequency, the tape speed and the frequencies that are being recorded are all important in the complete recording process and must be carefully controlled.

In addition to generating the alternating current to bias the record head, the bias oscillator also supplies power to the erase head. The erase head removes any previous recording that may have been on the tape before a new recording is made. The structure of the erase head is similar to that of a record head, but with a wider gap for better penetration of the magnetic coating on the tape. Its windings are designed to handle more current than the windings on some record heads. It is common

practice to have two gaps in an erase head, for more efficient erasing (see Fig. 1).

Much more power is required to drive the erase head than to bias the record head. This power must be provided either by the bias oscillator or by an amplifier that can handle the relatively high-frequency bias oscillator signal. Since power is transferred from the bias oscillator to the erase head, or from such an amplifier to the erase head, an impedance match is required. It is not as important to match impedances between the bias oscillator and the record head because only a relatively small amount of power is required here.

The ratio between the amplitude of the audio signal being recorded and the bias signal is fairly critical and varies with different recording heads. It is best to get specific information from the manufacturer of the tape recorder.

### Clues to improper bias

There are some simple ways of judging whether a record head is getting the correct amount of bias current. Low bias causes excessive high-frequency response in the recording, a noticeable lack of low-frequency response, low output, a tendency to distort on peaks of the audio signal and a high level of background noise.

Excessive bias increases the playback output of the recorded tape, but there will be a noticeable lack of high-frequency response. This happens because an overbiased record head will partially erase at the same time it is recording. This partial erasure begins at the higher audio frequencies.

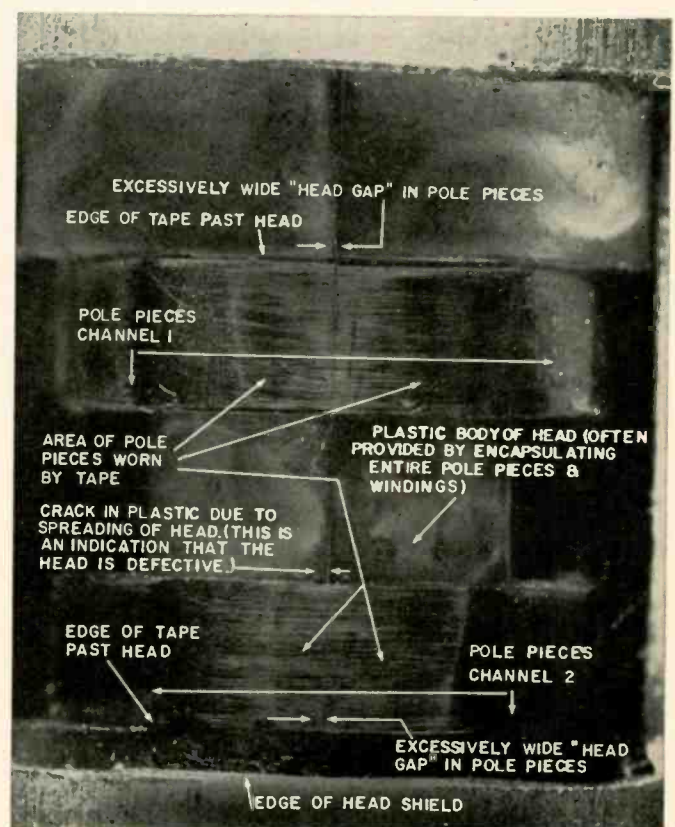
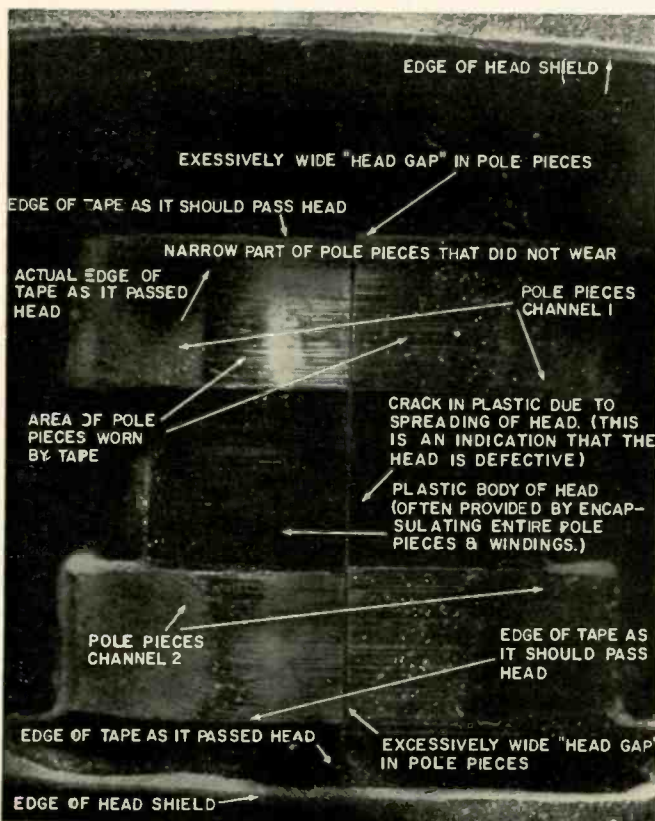

**Two examples of defective and worn tape heads. The plastic body of the heads has started to spread. This causes the gap to widen and response to deteriorate. Note the abnormal wear on the head on the left. The tape was not properly centered and the upper part of the upper pole piece is not worn.**

### LOW-IMPEDANCE RECORD HEAD

Inductance	.09 henry
DC resistance	140 ohms
Impedance at 1,000 cycles	565 ohms
Bias frequency	40-100 kc.
Recording bias current	0.9-1.5 ma
Recording audio current	.08 ma

### MEDIUM-IMPEDANCE RECORD/PLAYBACK HEAD

Inductance	0.3 henry
DC resistance	260 ohms
Impedance at 1,000 cycles	1,884 ohms
Bias frequency	40-100 kc.
Recording bias current	0.3-0.5 ma
Recording audio current	0.04 ma
Average output at 1,000 cycles	2 mv
Average output at 10,000 cycles	1 mv

### HIGH-IMPEDANCE PLAYBACK HEAD

Inductance	0.8 henry
DC resistance	400 ohms
Impedance at 1,000 cycles	5,024 ohms
Average output at 1,000 cycles	2 mv
Average output at 10,000 cycles	2 mv

If used for recording:

Bias frequency	40-80 kc
Recording bias current	0.25-0.4 ma
Recording audio current	0.025 ma

Figures given above are for selected quarter-track heads. Record level 12 db below saturation, at a tape speed of 7½ ips.

### LOW-IMPEDANCE ERASE HEAD (FULL TRACK)

Inductance	80 microhenries
DC resistance	0.3 ohm
Impedance at 60 kc	20 ohms
Erase current	300 ma

### HIGH-IMPEDANCE ERASE HEAD (HALF TRACK)

Inductance	85 millihenries
DC resistance	130 ohms
Impedance at 60 kc	20,000 ohms
Erase current	5-7 ma

Fig. 3—Typical specs of low-, medium- and high-impedance record, record-playback, playback and erase heads.

A lack of high-frequency response during playback does not always indicate that there is too much bias on the record head. A worn playback head or a record or playback head out of alignment with respect to the tape can also kill high-frequency response in playback. A clue to an overbiased condition is that the output will be high at the same time the high-frequency response is down. A worn or misaligned head causes poor high-frequency response and low output.

### Head impedances

Record and playback heads can be classified as low-, medium- and high-impedance. Since impedance is related to frequency, a record head represents two impedances. One is the impedance of the head at audio frequencies, and is usually given for 1,000 cycles. The other is the impedance of the head at the bias frequency. Frequently this is not given and must be calculated on the basis of the inductance and dc resistance at the bias oscillator frequency. It is not too important to know the exact impedance of a head, but the technician should be able to judge whether a head is in the general classification of low, medium or high impedance. The electrical specifications of typical heads in these three classifications are in Fig. 3.

High-impedance rf transmission lines

have resonant points, both in terms of line length and operating frequency. The same conditions exist in the circuit of a high-impedance erase or record head. When a parallel-tuned circuit, represented by the coil and circuit capacitances of an erase or record head, is tuned to resonance, the least amount of current flows. Resonances, then must be avoided or at least controlled in a recorder; because it will not record unless precisely the correct amount of bias current is flowing in the record head. By the same token, an erase head will not erase unless the correct amount of current is flowing in its windings. This point is most important in tape recording systems that are put together with individual components such as a separate tape deck and separate recording amplifiers.

Systems that use low-impedance heads are not as critical, because the connections to the heads are nonresonant lines. More power is required to drive low-impedance heads. It is often more difficult to control distortion levels when appreciable power is being handled. A recording amplifier for higher impedance heads can use simpler circuitry and be made to do a good job if it is designed to avoid problems of head resonances.

Resonances must be avoided or controlled in a good tape playback system just as in a good recording system. The cardinal rule, in a playback system, is to "keep the leads from the playback head as short as possible." Excessive lead length will cut down the high-

frequency response and not be as susceptible to resonance effects. Such a system is a little more expensive because of the transformer. Also, the transformer must be carefully designed and mounted to avoid hum pickup problems.

### Bias oscillator frequency

The normal operating frequency of the bias oscillator is important for determining the range of recording frequency response of a given recorder. The bias oscillator should operate at a frequency at least five times as high as the highest audio frequency to be recorded. This is because any harmonics lower than the fifth harmonic of the audio frequencies being recorded may be strong enough to heterodyne with the fundamental frequency of the bias oscillator and produce birdies in the recording.

Just as an example, let us assume that a tape recorder with a 30-kc bias oscillator is being used to record audio frequencies from 7,000 to 8,000 cycles. The fourth harmonic of 7,000 cycles is 28 kc. This harmonic can beat with the bias oscillator fundamental to produce an undesirable 2,000-cycle sound. It is possible that some trace of this 2,000-cycle beat note might become a permanent part of the recording put on the tape. Fig. 4 is a table that shows the beat notes that would appear for audio signals from 7,000 to 8,000 cycles under these circumstances.

Fifth and higher-order harmonics may be present in a recorder with the bias oscillator operating at a frequency five times the highest audio frequency being recorded, but they are usually too weak to cause serious trouble.

It might appear that all tape recorders should be designed with bias oscillators that operate at high frequencies, particularly if high fidelity is the objective. But this introduces complications of excessive radiation from the bias oscillator into other parts of the recording amplifier, losses caused by capacitance effects in parts of the circuit, and head resonances if high-impedance heads are used. Most recorders, therefore, use bias oscillator frequencies below 70-kc.

The bias oscillator in a tape recording amplifier often is more or less independent of any other sections of the amplifier except for a common power supply. It is connected to the record head at the output of the record amplifier in some kind of a shunt-feed arrangement. There are exceptions, but this is the most common system. The block diagram in Fig. 5 shows the bias oscillator in relation to the rest of the complete recording amplifier. END

AUDIO FREQUENCY BEING RECORDED (CYCLES)	FOURTH HARMONIC (CYCLES)	BIAS OSCILLATOR FREQUENCY (CYCLES)	NEAREST BEAT NOTE (CYCLES)
7,000	28,000	30,000	2,000
7,100	28,400	"	1,600
7,200	28,800	"	1,200
7,300	29,200	"	800
7,400	29,600	"	400
7,500	30,000	"	0
7,600	30,400	"	400
7,700	30,800	"	800
7,800	31,200	"	1,200
7,900	31,600	"	1,600
8,000	32,000	"	2,000

Fig. 4—Beat notes between fourth harmonics and a 30-kc bias oscillator.

frequency response from high-impedance playback heads, unless the system is deliberately designed with resonances that tend to improve the playback frequency response.

The highest-impedance heads frequently are used for playback, because they have the best output. A low-impedance playback head with a transformer to match it to the input of the playback preamp will have good high-

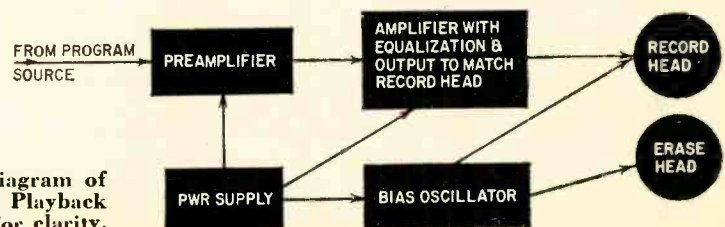
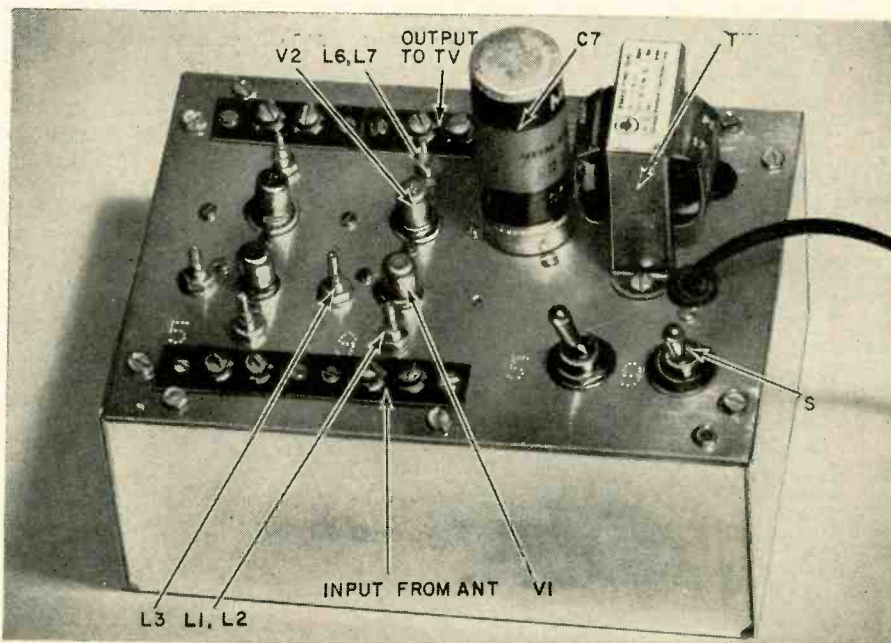

Fig. 5—Block diagram of a tape recorder. Playback section omitted for clarity.

# Nuvistors cut noise in VHF TV booster

Build this unit and get frame-grid noise figure with a \$2.36 tube



Completed two-channel booster. One channel (5) covers the low-band; the other (9), the high band.

## By JOHN R. LANGE, K9ARA

IN FRINGE TV AREAS THE SNOW CONTRIBUTION or noise figure of a TV booster or rf stage is mainly determined by the tubes used. Most commercial TV tuners average noise figures of about 5 to 6 db on channels 2 to 6, and 7 to 9 db on channels 7 to 13. Some of the later boosters and tuners using the newer frame-grid type tubes may give noise figures of about 3 to 5 db on channels 2 to 6, and 4.5 to 6 db on channels 7 to 13.

The importance of noise figure can be appreciated when one realizes that a 3-db reduction in noise figure at a quiet receiving location reduces TV snow as if the receiving antenna were

stacked with another or the TV station's transmitted power doubled. My previous TV booster design, which appeared in the November 1957 issue of RADIO-ELECTRONICS, used frame-grid tube types such as the 417A, 6688 or 5847 for the input stage to get lowest possible noise figures. However, these tubes cost anywhere from \$7 to \$15, and the second 6AJ4 around \$4.

But recently the RCA 6CW4 nuvistor has appeared. This tube gives noise figures at vhf within 0.25 db of those obtainable with the more expensive frame-grid tube types. This \$2.36 tube also takes less power and simplifies the power supply requirements.

The two-channel cascode type

booster shown in the photographs was built to evaluate the nuvistor for TV booster use and to improve Chicago TV reception from the two stations featuring nearly continuous local color TV programming. Total cost for parts was under \$20. Noise figures are about 3.25 db on channel 5, and 5 db on channel 9. Snow reduction and color picture improvement was surprising and as good as that obtained with the previous triode-connected 6688, 6AJ4 booster.

The two-channel booster was built on a 5 x 7-inch No. 16 aluminum sub-chassis complete with power supply and is mounted in a 3 x 5 x 7-inch aluminum chassis base. It would be even better to use a brass subchassis since ground

Fig. 1—Circuit of the nuvistor TV booster. Only one channel is shown.

### PARTS LIST

R1, R2—47 ohms, 1/4 watt  
R3, R4—1,800 ohms, 2 watts  
R5—47 ohms, 1/2 watt  
C1, C2, C3, C4, C5, C6, C8, C9, C10, C11—.001- $\mu$ f ceramic for channels 2 to 6. 500- $\mu$ f ceramic for channels 7 to 13  
C7—15-15  $\mu$ f, 475 volts (Mallory FP-258 or equivalent)  
L1, L2, L3, L4, L5, L6, L7—see coil-winding table  
RECT—IN1763, 500 ma, 400 PIV  
RFC1, RFC2—see coil-winding table  
S—dpst toggle  
T—power transformer; primary, 117 volts; secondary, 125 volts, 15 ma; 6.3 volts, 600 ma (Stancor PS-8415 or equivalent)  
V1, V2—6CW4 nuvistors  
Chassis, 5 x 7 inches, No. 16 gage aluminum or brass Case, 3 x 5 x 7-inch aluminum chassis  
Sockets for tubes, Cinch-Jones 5NS or equivalent  
Miscellaneous hardware

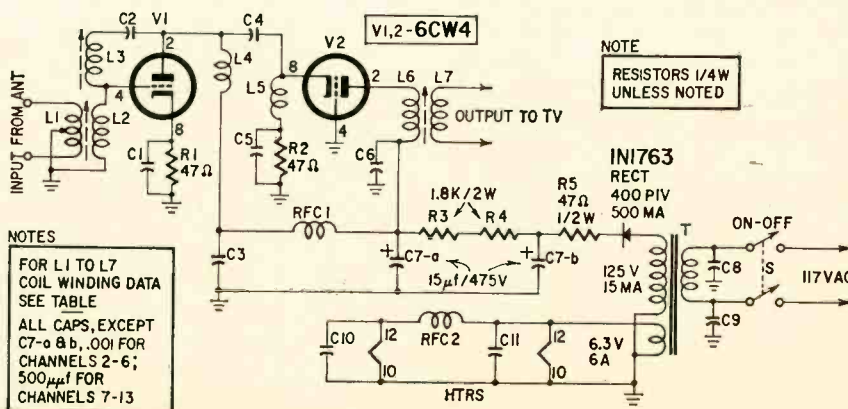

connections and the nuvistor sockets could then be soldered in. I used 2-56 machine screws to fasten down the sockets, ground lugs and standoff terminals.

Plate power is switched to either the booster peaked for channel 5 or the one on channel 9. Input and output leads are quickly shifted, using clothes-pin type antenna clips. Because of the modest power requirements, power could probably be taken from the TV set since only about 40 to 70 volts at about 18 ma is required for plate power. A single-channel unit could then be mounted in a small case and hidden inside the TV set. For ultimate single-channel fringe-area use, the booster could be built in a weatherproof box and mounted up near the antenna with power being sent up externally. Fig. 1 gives the circuit for a single-channel booster. For a two-channel booster, add two more nuvistor stages. The power supply can be switched to both amplifiers. To avoid interference, switch off plate voltage of the unused channel.

### Build-it hints

Carefully bend out the two opposite tabs on the nuvistor socket horizontally and orient the plate lead, pin 2, toward the output after inserting the socket in a 1/2-inch diameter hole. If a brass plate is used, solder the socket tabs in place. For an aluminum plate, drill a clearance hole for a 2-56 screw in each tab and bolt the socket down.

No interstage shields are used on the subchassis. A 2-inch-wide shield inside the base, up from the floor and even with the center lines of the second-stage sockets, may eliminate regeneration in some layouts. This will help reduce coupling between the input and output coils if they are too close to each other.

Lead lengths of the input-tube cathode bypass capacitor, C1, and the grid grounding strap at pin 4 of the second stage should be as short and direct to a chassis ground as possible. Other lead lengths are not too critical if the layout shown in the photos is generally followed.

The input transformer coil has an important effect on the booster's noise figure. The coils are overcoupled past the point of maximum gain to present to the tube an impedance giving lowest noise figure. Cambridge Thermionic 1/4-inch diameter forms were used. The high-frequency powdered-iron cores (coded white) for 30-mc and higher were used. Lower-frequency ordinary if cores will lower the coil Q and increase the noise figure.

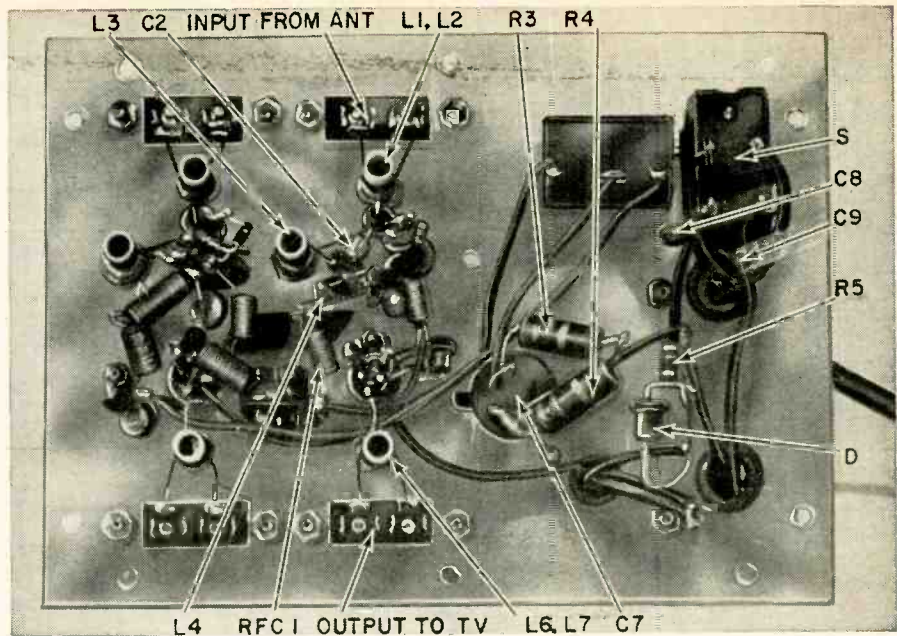

Parts layout under the aluminum or brass chassis.

The low-band input, neutralizing, and output coils were wound tightly with No. 28 enameled wire. Apply a coat of polystyrene cement (used on plastic models and available at hobby shops) and let the coils dry for a day before winding the input or output windings on top in a reverse direction. Do not use regular model-airplane type cements since they lower coil Q.

Center-tap input coil L1 by scraping the enamel from about a 1-inch length of lead after the coil is half wound. Place another scraped lead in parallel and twist the two leads several times. Then coat them with solder, and wind the remaining half of the coil. The two twisted and soldered leads then come out at right angles to the coil and are soldered to a ground point. Check with an ohmmeter to make sure that windings L1 and L2 are not shorted.

Wind the coils for channels 7 to 13 with No. 24 wire. This is easy to do after the forms are mounted in the chassis. The rf chokes and interstage coils, L4 and L5, are tightly wound over a 3/16-inch-diameter rod or drill shank. By scraping the enamel off, tinning with solder and bending the leads before sliding out the rod, the choke will not be distorted when soldered into the circuit.

### Booster alignment

The booster can be peaked with a

TV station signal, but for best results use a sweep generator, oscilloscope and 300-ohm balanced detector pad as shown in Fig. 2 to get a properly centered overall bandpass alignment. First, however, center the input circuit response for best noise figure. This can be observed by disconnecting L6 from the circuit and temporarily replacing it with a 150-ohm resistor. Touch an rf crystal demodulator probe connected to the scope to the plate end of the 150-ohm resistor and observe a broad single-peaked curve. Center this curve by adjusting the input and neutralizing coil cores on the desired TV channel. The number of coil turns on L2 may have to be varied a turn or so if the response cannot be centered using the coil cores.

Then remove the resistor and reconnect L6. Now check overall response using the 300-ohm balanced detector probe. The curve should have the shape shown in Fig. 2-b and the core of the output transformer coil should maximize the curve center at the desired channel. On channel 2 or 3, the overall curves may be too narrow for good color TV definition. Widen bandwidth by soldering a 15,000-ohm (or lower value) resistor in parallel with L6, from the plate of V2 to C6. Bandwidth can also be widened by increasing the number of turns on L7. Gain will be lowered but there will be little effect on the noise figure. For extreme black-

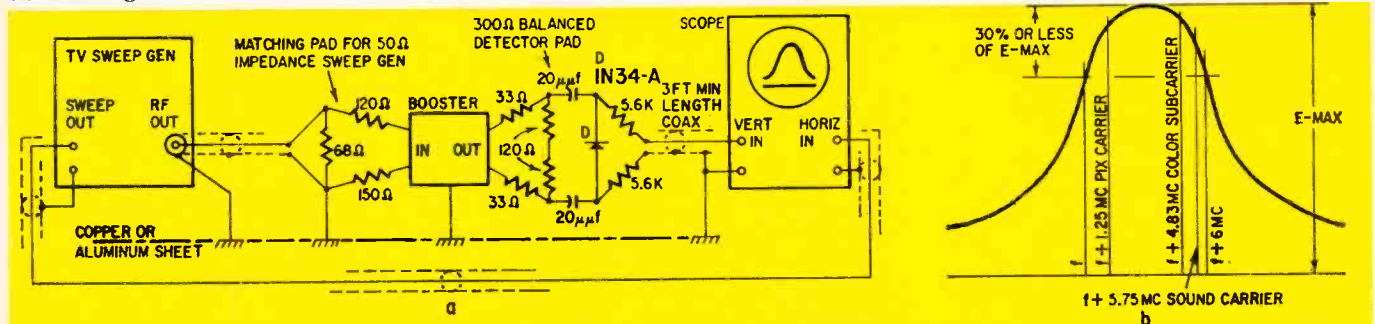

Fig. 2—Sweep alignment setup (a) and desired response curve (b).

**Coil-Winding Data**  
All Coils Use Enameled Wire

TV Channels	L1		L2		L3		L4, L5		L6		L7		RFC1, RFC2	
	Turns	Wire No.	Turns	Wire No.	Turns	Wire No.	Turns	Wire No.	Turns	Wire No.	Turns	Wire No.	Turns	Wire No.
2	7½	28	12	28	30	28	31	24	14	28	6	28	15	24
3, 4	6½	28	10	28	25	28	27	24	12	28	4½	28	15	24
5, 6	4½	28	7	28	20	28	22	24	9	28	3½	28	15	24
7, 8	3½	24	3½	24	6½	24	7	24	4½	24	3	24	15	24
9, 10	3	24	3	24	5½	24	6	24	4	24	2½	24	15	24
11, 12, 13	2½	24	2½	24	5	24	5	24	3½	24	2½	24	15	24

**Notes**

L2, L3, L6 are tightly wound on ¼-inch-diameter slug-tuned coil forms such as James Millen 69048-B with No. 19 mix core (coded white) or Cambridge Thermionic Corp PLS-6 or IS-6 with 20063-D core (coded white.) L1, center-tapped, and L7 are reverse-wound over L2 and L6, respectively. L4, L5, RFC1, and RFC2 are air-core tightly wound chokes, 3/16-inch diameter.

and-white fringe-area reception, high gain and narrow bandwidth may be desirable.

Bandwidth can be increased to give a flat response over several TV channels on either side of a single channel picked according to coil-winding data. Simply wind the input and output windings (L1 and L7) below, and separated 1/32 to ½-inch from, grid and plate windings L2 and L6. Also add 7 to 45-µmf trimming capacitors across L1 and L7. Check and align the input response first, then the overall response. When adjusting the double-tuned coils, you'll find that separation between the two windings will mainly determine the bandwidth. The capacitor will tilt the curve, and the core maximizes the curve amplitude in general at the desired frequency range. There is some interaction in adjustments.

**Final test**

Make final adjustments with the TV signal and TV set. Pick a time when the signal is weak, but not fading, and external interference is at a minimum. Connect the booster between the antenna and TV set. Make sure input leads, output leads and power cord are separated from each other. Use as short a lead as possible between the booster and TV tuner.

Turn on the TV set and booster and after sufficient warmup time (at least 15 minutes) adjust the output coil core for maximum picture contrast and the input and neutralizing coils for maximum picture contrast and least picture snow. Note the snow content of dark picture areas while tuning the booster. Sometimes, particularly on channels 7 to 13, wrapping a 4-inch square of aluminum foil around the input lead and sliding it along 1 to 4 feet from the booster will improve the picture. Readjust or remove the slider, however, when viewing other channels.

I found that reducing the size of input tube cathode bypass capacitor C1 from 500 to 50 or 100 µmf, reduced bandwidth and optimized the noise figure on channel 9. However, too small a capacitor will cause oscillation.

If the booster oscillates (indi-

cated by a white or torn raster on the TV screen), turn off the booster and retune neutralizing coil L3 until there is no oscillation when the booster is turned on again. Oscillation may occur when the booster is located at the antenna or some distance from the TV set. It can be caused by radiation from the long output lead being picked up by the antenna. If this is happening, use 300-ohm shielded line between the booster and TV set.

If a 75- to 300-ohm transformer is connected to the TV tuner, coax can be used between the booster and TV set. For coupling to a 75-ohm coax line, cut the number of turns on L7 in half and ground one end of the coil. Persistent oscillation may require adding a 15,000-ohm or lower value damping resistor across L6, as mentioned previously, to lower the gain and increase bandwidth, particularly on channels 2 and 3.

If the booster gives little or no improvement, check operating voltages. Plate voltage should be around 70 and total current drain about 18 ma. For longest tube life in antenna-mounted units, lower plate voltage to about 40 by increasing the value of R3 and R4, with a negligible change in noise figure.

END

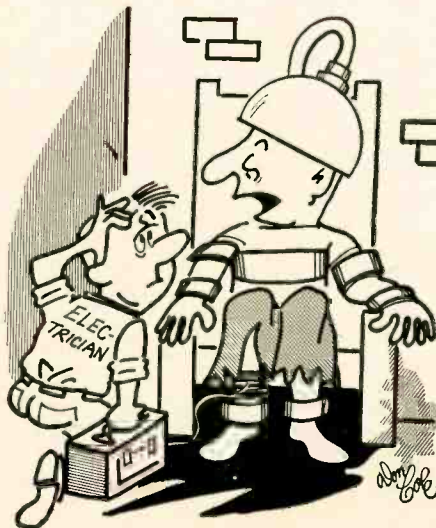

"Ac or dc?"

# LOOK FOR THESE FEATURES IN Radio-Electronics NEXT MONTH

## HAND-HELD RADAR FOR THE FOOT SOLDIER

G. I. Joe goes electronic!

With this 10-pound instrument, the modern "dog-face" can spot enemy movements a mile away under any weather or light conditions. It audibly distinguishes between such targets as tanks or personnel.

## ELECTRONIC IGNITION IN YOUR CAR

Start easier, improve engine performance, save gas with this all-solid-state system. It's easy to build, easy to install.

## BOAT-ELECTRONICS— WHAT'S NEW

Veteran marine service technician Elbert Robberson reviews the new 1962 electronic aids for small boat owners.

## SERVICING THOSE COLOR CIRCUITS

Color TV circuits aren't as complex as they're painted. Common sense makes handling them much easier. This article lights the way.

## HIGHWAY RADAR NABS SPEEDERS

A highway radar maintenance man answers your questions. Tells you how accurate highway radar is, whether or not it can be confused. Gives you the lowdown on radar detectors. A very timely feature for Summer drivers.

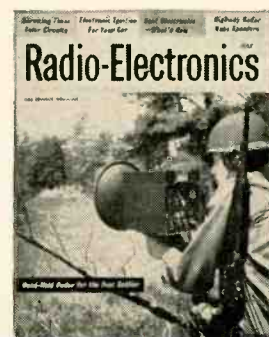

**JULY ISSUE ON SALE JUNE 19**



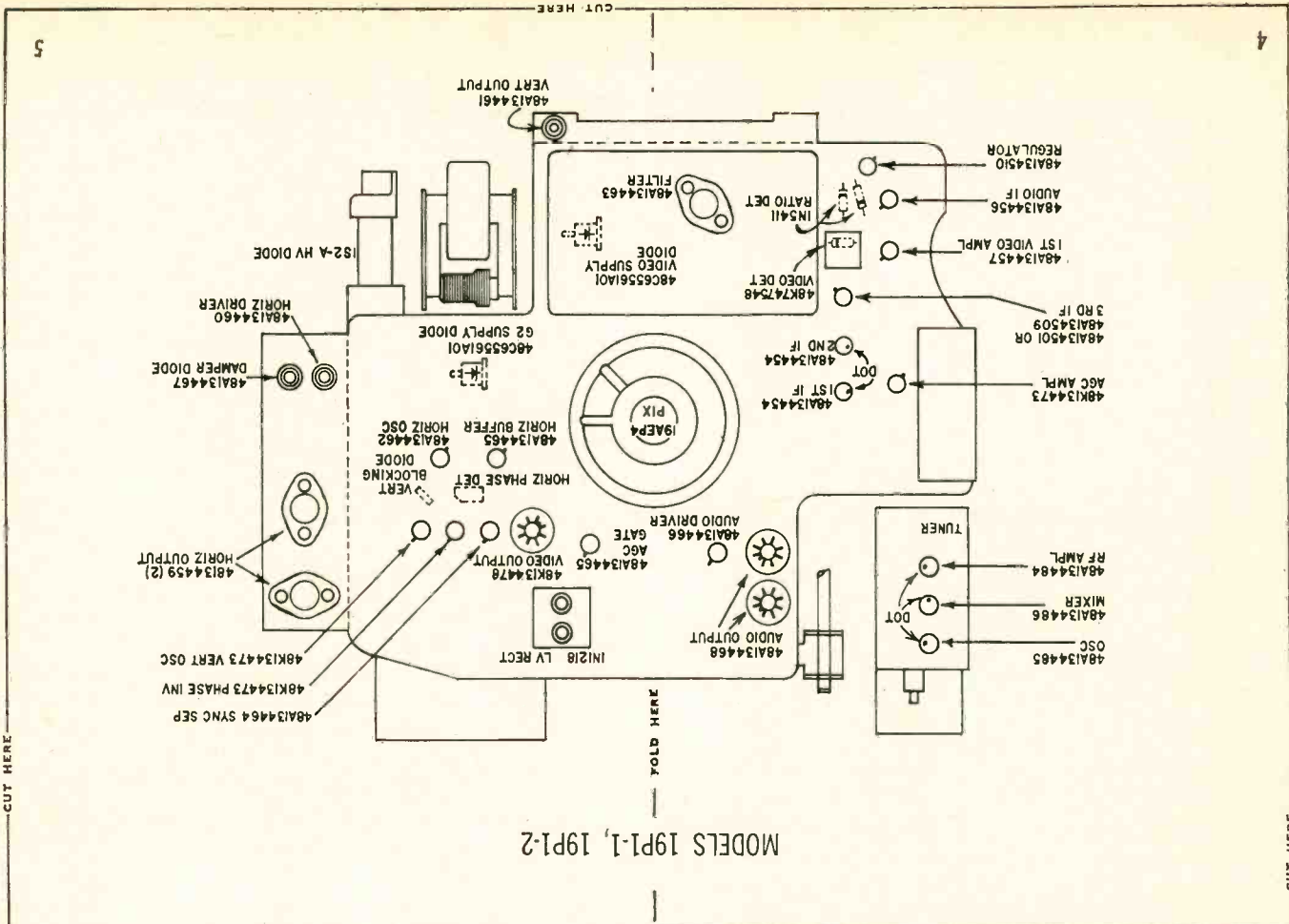

## SAVE! Arrow's T-25 Staple Gun Saves You Time and Money!

For Wire Up To 1/4" in Diameter . . . Bell, Thermostat, Radiant Heat, Telephone, Inter-com, Burglar Alarm, etc.

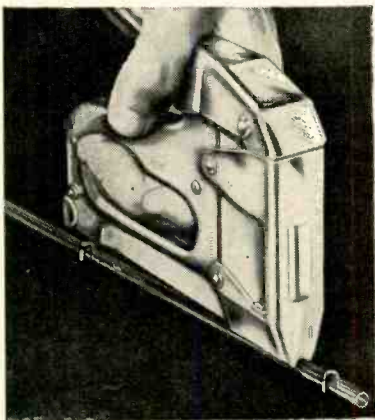

Tapered striking edge gets into tight corners!  
**T-25 AUTOMATIC STAPLE GUN** for wires up to 1/4" in diameter. Uses 9/32", 3/8", 7/16", 9/16" round crown staples, galvalloy coated for high rust resistance.  
**LIST \$15.**

### SAFE!

Can't damage wire because staples automatically stop at right height! Won't even break 1/4" hollow glass tubing.

### FAST!

Proved by test 10 times faster than old hammer method. Saves you 70% in fatigue and efficiency . . . saves many dollars a year.

### HOLDS!

New staples get tremendous holding power from tack points that spread to lock themselves into wood!

Write for catalog and information.

**ARROW FASTENER COMPANY, INC.**

One Junius Street • Brooklyn 12, N. Y.

Radio-Electronics

# TUBE LAYOUTS IN TV SETS

Compiled by Larry Steckler, Associate Editor

MOTOROLA 1961-1962

### HOW TO FOLD

Fold the top down and back, keeping the cover facing you. Then trim the right and left edges. Now staple the booklet along the vertical center fold, about 3/4 inch from the top and bottom. Now fold from left to right, keeping the cover facing you. Trim a fraction of an inch off the top and trim the bottom to size and you're finished. You now have another useful piece of service data, exclusive with RADIO-ELECTRONICS.

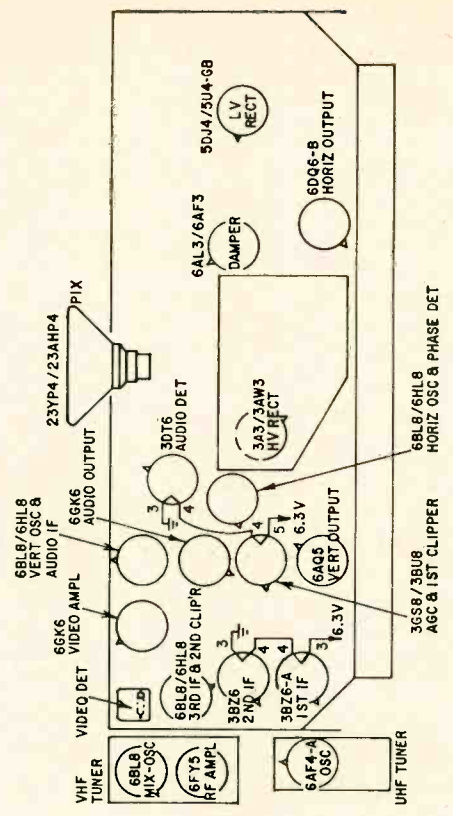

CHASSIS STS-570, ST-570

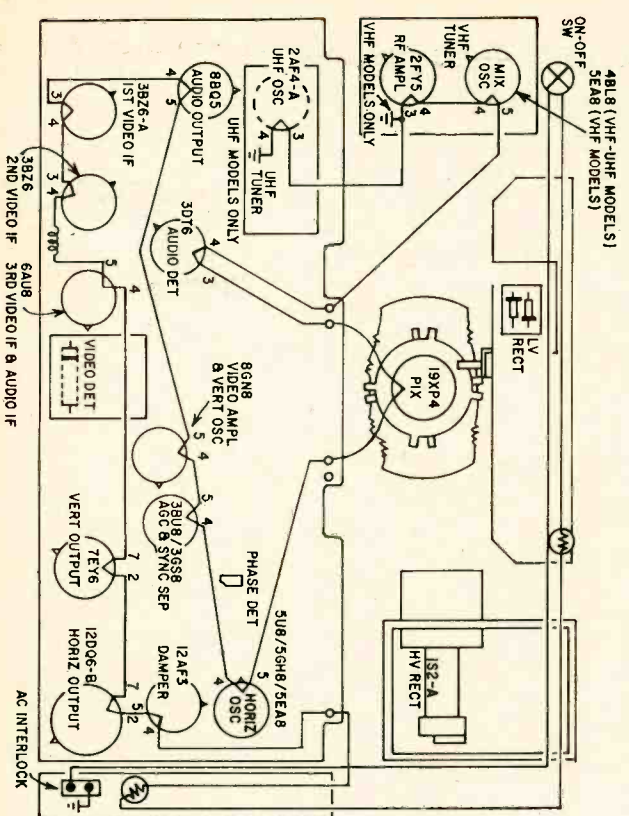

CHASSIS RTS-433, TS-440

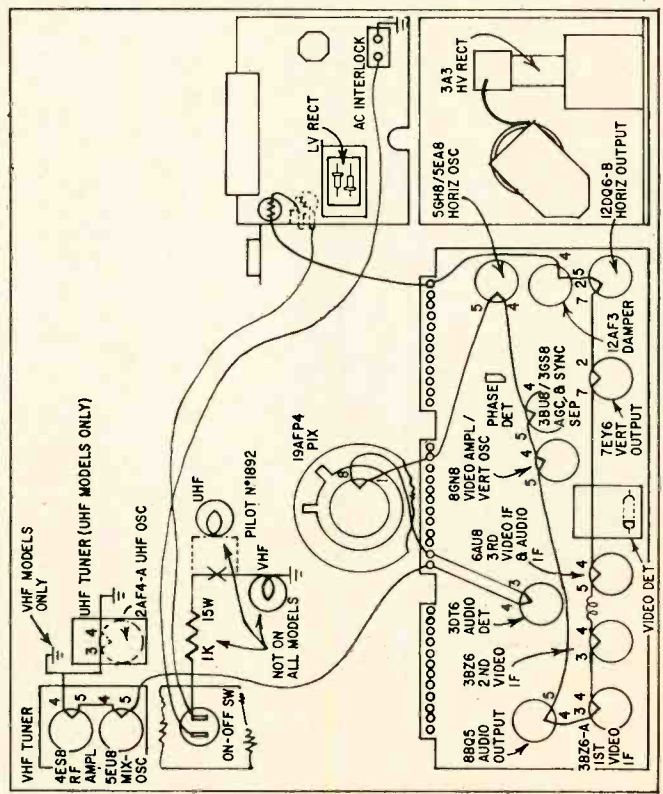

CHASSIS TS-ST5, WTS-435

CHASSIS WTS-569, STS-569

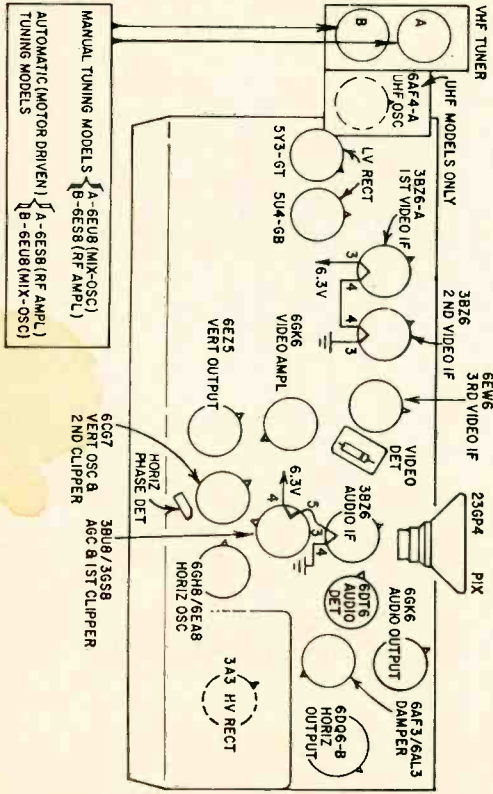

MANUAL TUNING MODELS (A-6E58 (MIX-OSC) B-6E58 (RF AMPL))  
 AUTOMATIC (MOTOR DRIVEN) (A-6E58 (RF AMPL) B-6E58 (MIX-OSC))

**LASER PACKS A WALLOP.** The intense beam of light was powerful enough to burst a balloon 10 feet away. Fragments of the balloon are just starting to drop to the floor. In another test the laser beam was used to punch a hole through a sheet of stainless steel. The laser fired a 1/2000-second burst of light. Both demonstrations were conducted at the IRE show.

**RUNAWAY MISSILES AND SATELLITES** are destroyed when these musical rods are triggered with the right combination of tones. If the correct five tones are not received, nothing happens—this keeps stray signals from triggering the destruct mechanism and killing an astronaut or destroying a valuable missile. The tuning rods are made by Raytheon and are part of a command receiver supplied by Thompson Ramo Woolridge to missile manufacturers.

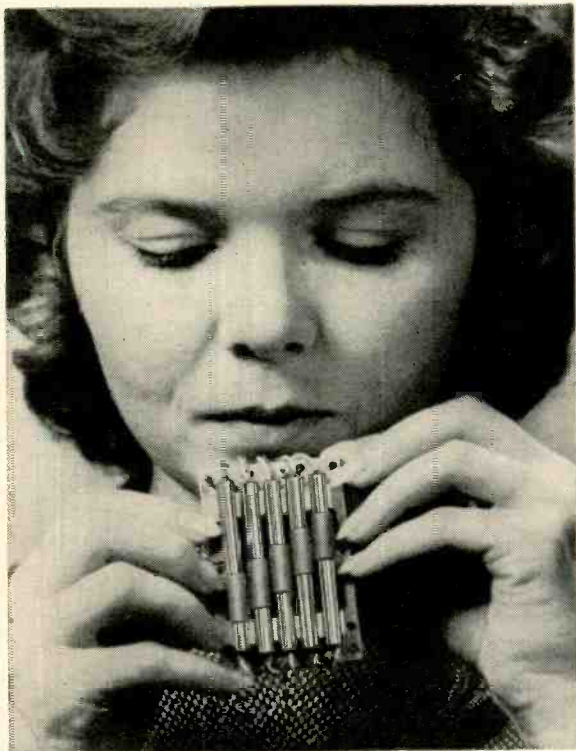

**SPACE COMMUNICATIONS SYSTEMS** will make good use of this Amplitron. It delivers 25 watts at 2300 mc and is well suited for telemetering packages, voice and facsimile transmission from space, or in equipment where light weight and small size are important. This new Raytheon tube weighs only 16 ounces.

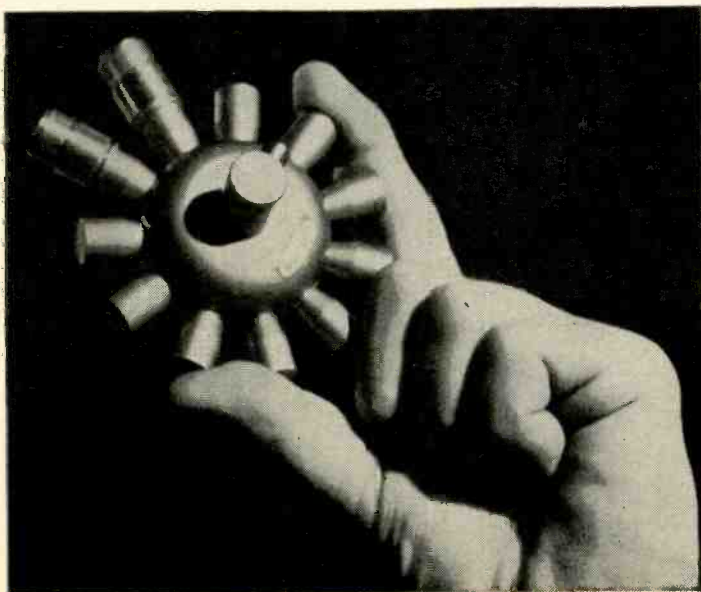

## What's New

**SOLDERING TWEEZERS** should be an excellent tool for semiconductor circuits. Separate 6-watt element in each arm applies heat to the transistor, diode, or other semiconductor lead directly. Solders fast with a minimum of heat. The Oryx-made tool is imported from England.



# unusual oscilloscope techniques

*Some methods used in industry could be valuable in TV Service*

By **ROBERT G. MIDDLETON**

SCOPES IN INDUSTRY ARE BECOMING almost as universal as voltmeters. The quality-control department in a semiconductor plant is full of them. With suitable adapters we can display a complete family of plate characteristics for a tube or collector characteristics for a transistor. Although we do not usually think of a plate-characteristic plot as a waveform, the ingenuity of electronic engineers has translated the oscilloscope virtually into an electronic computer which performs instantaneously analyses that would require hours or days to complete with point-by-point measurements, graph paper and slide rule.

Auto electricians now use the scope to check engine ignition systems, which used to be checked with a screwdriver within recent memory. Special probes reduce the high-tension spark voltage for the scope. The low-tension waveforms in the ignition system are also displayed concurrently or consecutively. The scope operates as a voltmeter, showing instantaneous voltage values as waveforms on a linear time base. The up-to-date auto mechanic is as familiar with oscilloscope operation as with hex wrenches and hydrometers.

The oscilloscope finds vital application in the manufacture of ferrite cores to operate as ultra-speed memories in computers. For example, Fig. 1

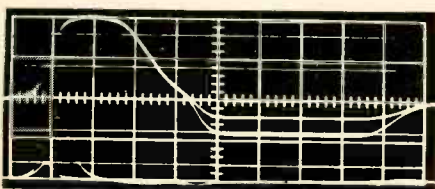

Fig. 1—Drive and switching time waveforms show the extremely fast response of a computer type ferrite core. Time is 0.02  $\mu$ sec per division. Ampex.

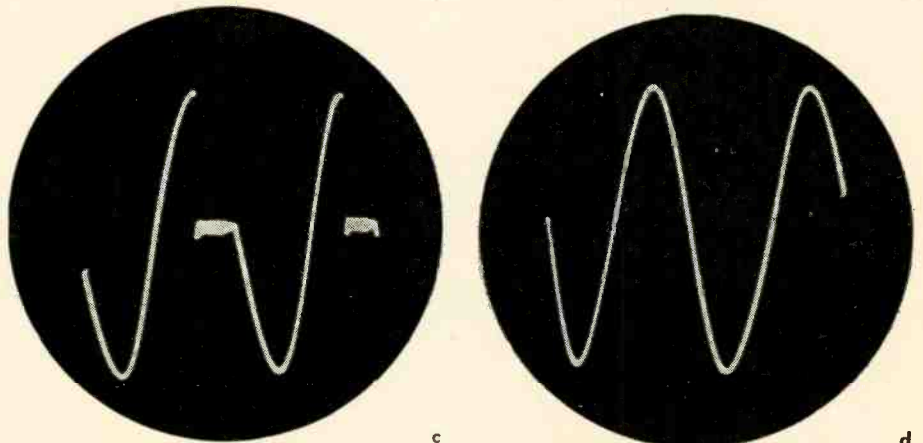
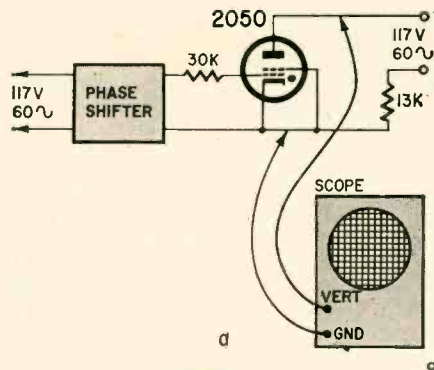

Fig. 2—Anode-cathode waveforms for thyatron rectifier circuit. a—Where scope was connected. b—Full anode current. c—Medium anode current. d—Zero anode current.

shows the drive and switching-time waveforms for a fast-response computer type core. This type of memory product provides a clear-write and read-restore memory cycle at rates to 1 mc. If a permanent record is required, special cameras are used to photograph the screen pattern.

## Varieties of scope patterns

Of course, there are many types of scope patterns in practical electronics work. Some are well known, others are

just beginning to be generally recognized. Let us look at some of the more important pattern characteristics to see why they are so informative in electronic test procedures.

Patterns displayed on a linear time base are both familiar and of general utility. Fig. 2 is an example. This display shows a thyatron rectifier circuit operating at three different conduction angles. Both grid and anode are supplied with ac. Average plate current is controlled by a phase shifter

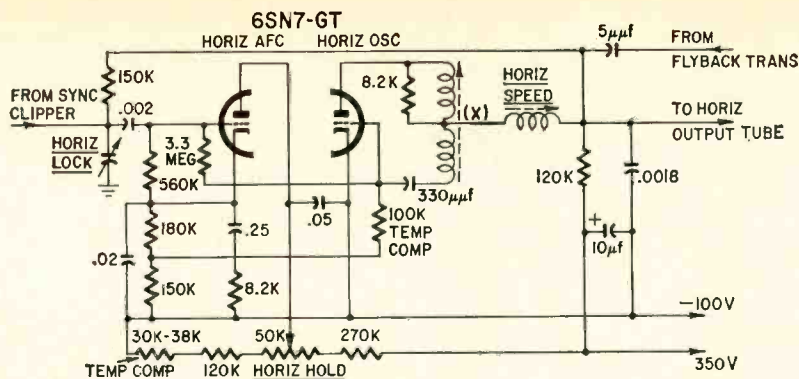

Fig. 3—Pulse-width afc circuit is checked with scope at X.

in the grid circuit. Thus, although the grid does not control the amplitude of the anode current, it does control the angle of current flow. Thus it controls

the average anode current. Current flows only during the horizontal intervals of the anode voltage waveform. The horizontal interval appears somewhat fuzzy because of plasma oscillation during conduction by the tube.

Next, let us look at Fig. 3. This is a pulse-width automatic-frequency-control (afc) circuit. It is commonly checked with a scope at X. Typical patterns are shown in Fig. 4. They are traced on a 5,250-cycle sawtooth linear time base and three complete cycles are displayed.

A visual-response curve, on the other hand, is usually displayed on a 60-cycle sine-wave time base. Fig. 5 shows a typical frequency-response

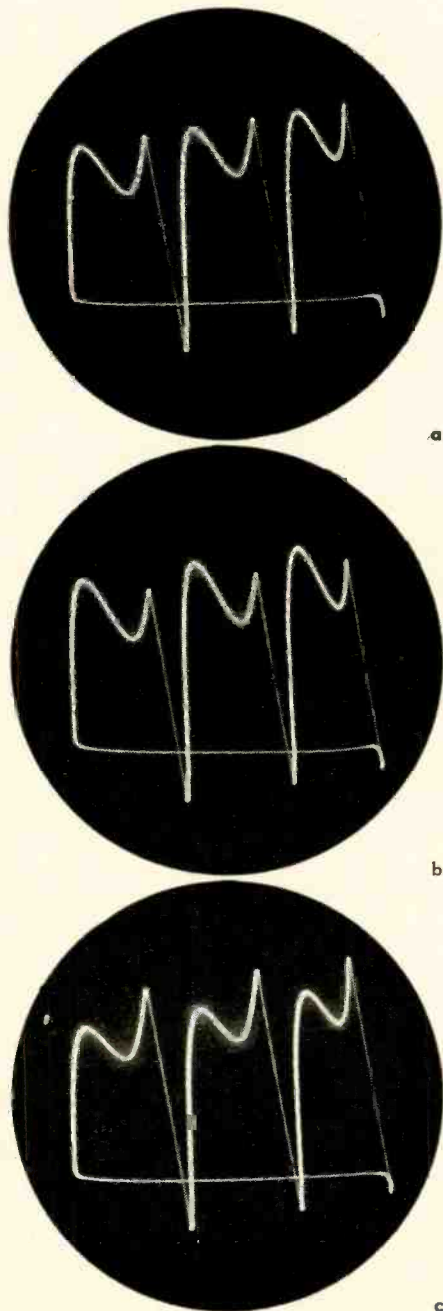

Fig. 4—Waveforms at X in Fig. 3. a—Normal. b—Pulse peak too low. c—Pulse peak too high.

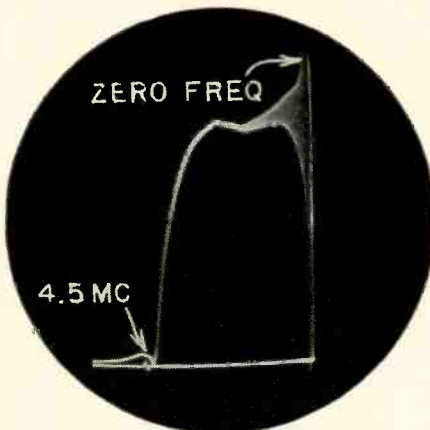

Fig. 5—Appearance of a typical video response curve.

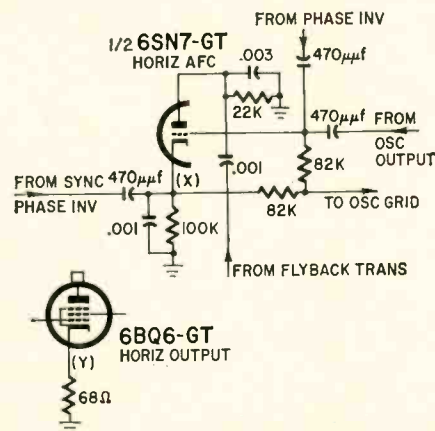

Fig. 6—Low-capacitance probe is connected at X. Scope's horizontal input is connected at Y. If the horizontal output tube's cathode is grounded, the waveforms in Fig. 7 will not be seen unless a small resistance is inserted.

curve for a video amplifier. The video amplifier should not be confused with the i.f. amplifier. The video amplifier in a TV receiver is the section between the picture detector and the picture tube. Beginners sometimes ask about the prominent "marker" which appears around zero frequency. This is not actually a marker though it can be regarded as such. The pseudo marker is a byproduct of practical demodulator probes, which have incomplete demodulating and filtering action at very low frequencies.

### Cyclogram displays

Less familiar to many of us, perhaps, is the cyclogram type of display, which is highly useful in industrial work and could be used much more in TV service. Note the partial afc and horizontal output circuits in Fig. 6. We get a cyclogram display by connecting the vertical input lead of the scope at X and the horizontal input lead at Y. Use a low-capacitance probe at X to avoid waveform distortion caused by circuit loading. In a cyclogram pattern, a signal voltage from a circuit is "swept" by another signal voltage from the same circuit (or equipment section). The ground lead from the scope is connected to the receiver chassis or common ground bus of the equipment under test.

Thus, a cyclogram is really two waveforms in one integrated pattern. The horizontal excursion of the beam is no longer a uniform time-axis function but has become a signal-voltage function. To put it another way, the signal information is developed both vertically and horizontally on the scope screen. The total information provided is not only doubled, but new data are displayed concerning instantaneous relationships between the two signal voltages. Of course, reading cyclograms is somewhat more difficult than reading simple patterns displayed on linear time bases.

When various circuit faults occur, the normal cyclogram pattern changes (Fig. 7). Note how different capacitor defects cause characteristic changes in the cyclogram pattern. We see that many circuit troubles show up clearly as distortions of the cyclogram pattern. Although unfamiliar to most of us, cyclogram patterns are actually easier to work with than ordinary sawtooth time-base displays.

Cyclograms are easier to use because no scope synchronizing adjustment is required. We switch off the sawtooth time-base function in a scope when displaying cyclograms. We do not use the sync controls of the scope. A cyclogram pattern is *automatically* locked on the screen at all times.

A cyclogram has two amplitudes, or peak-to-peak voltages; a certain vertical amplitude and a certain horizontal amplitude. Changed amplitudes in either direction are indications of circuit trouble, just as are pattern distortions. Hence, we calibrate a scope *both* vertically and horizontally when working with cyclogram patterns.

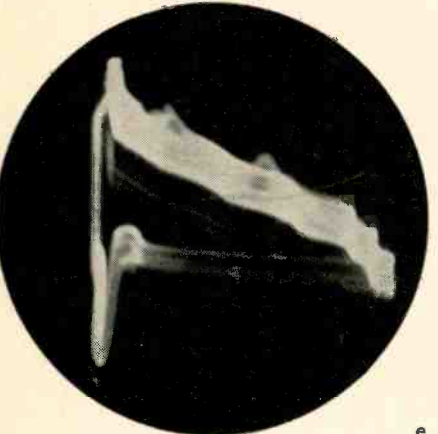
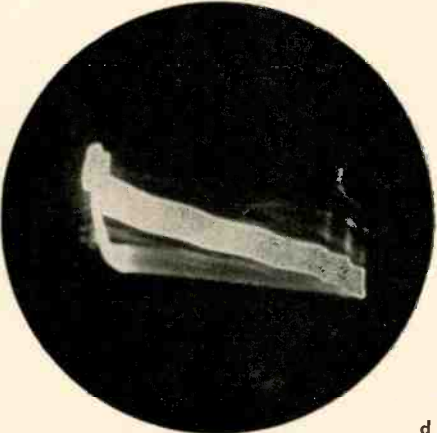
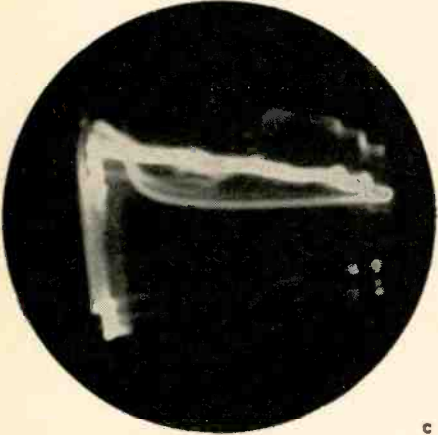
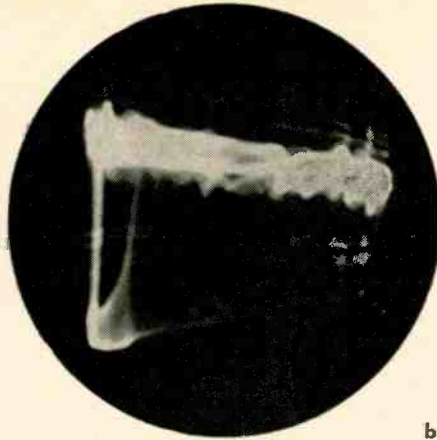
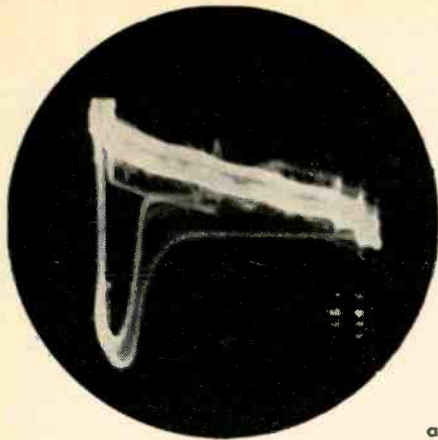
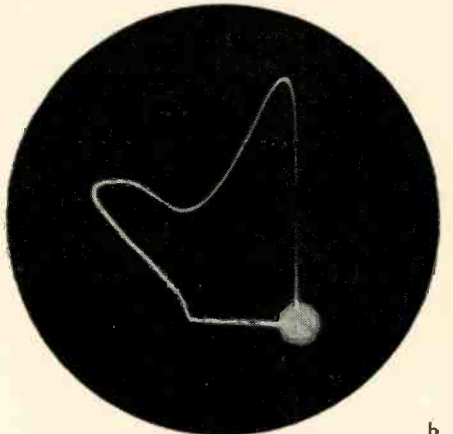
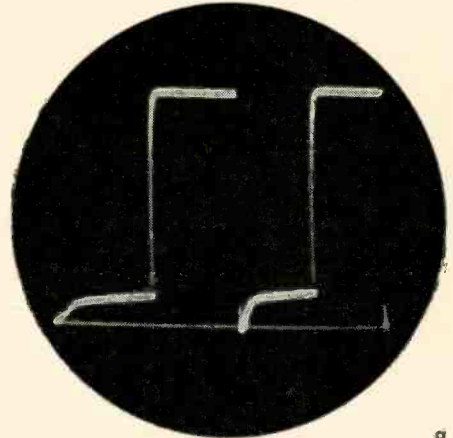

**Fig. 7—Comparison of afc cyclograms for various open afc capacitors. a—Normal cyclogram at afc cathode. b—Grid-coupling capacitor to inverter is open. c—Plate-coupling capacitor to flyback is open. d—Cathode-coupling capacitor to phase inverter is open. e—Grid-coupling capacitor to oscillator is open.**

ples of nonlinear resistance. Nonlinear resistance produces curved-line cyclograms.

Another important characteristic is the brightness variation in the pattern. This is true of patterns displayed on a sawtooth time base, as well as of cyclograms. In Fig. 8 the leading edge of the square wave (displayed on sawtooth sweep) is much brighter than the trailing edge. This shows us that the rise time is greater on the leading edge than on the trailing edge.

Again, in Fig. 8 observe that the cyclogram pattern brightness starts with a "sunburst" display and then diminishes clockwise around the cyclogram. A *small* change in pattern shape can be accompanied by a *large* change in brightness variation. Circuit trouble is indicated by the abnormal brightness variation.



**Fig. 8—a—Leading edge of square wave has a comparatively slow rise time. b—Cyclogram starts with sunburst display and traces area contour with diminishing brightness clockwise.**

We've kind of run out of space, so we'll stop here. A later article will show you just what scope patterns on a differential-input scope look like and we'll spend a little time with some interesting dc waveforms. **END**

All cyclograms obey electrical laws, which the electronic technician should keep in mind. First, we can obtain cyclograms between any two points in a circuit and such patterns may or may not enclose an area. If an area is outlined by the pattern, we know that there is reactance between the two test points. If a straight or curved line which encloses no area is displayed, we know that there is no reactance, but only resistance, between the two test points.

The resistance in an electronic circuit may be linear or nonlinear. Ordinary composition and wirewound resistors are linear. In other words, they produce a straight-line cyclogram when tested by any ac voltage, whether sine-wave, square-wave, sawtooth, pulse or other voltage waveform. On the other hand, transistors, semiconductor diodes, and class-B amplifier stages are exam-

**Beginning with our next issue, *Radio-Electronics* will gradually introduce a new, larger type, aimed at making articles easier and quicker to read. Watch for the new style! We will welcome comments from our readers as to the new typography and any other features in our makeup and layout which you feel might be improved.**

# automation makes golden resistors

*Noble metal under end-caps is key to automated production, increases reliability and cuts noise*

By **ERIC LESLIE**

WHEN IT BECAME NECESSARY TO TURN out high-quality, absolutely reliable resistors in almost astronomical quantities for the Armed Forces and the Bell Telephone System, Western Electric engineers were faced with some completely new production problems. The resistors had to be of the deposited-carbon type, of the reliability required for missile applications, and were required in quantities of several tens of millions, annually. Old methods simply would not work, and a completely automated production line was set up.

One of the special features of the line is that both production and quality are controlled by computers, so that reliability is maintained at all points during production, rather than by final inspection. The resistors are made by depositing a thin layer of carbon on a ceramic core. The traditional method of terminating such resistors has been to apply a silver paste to the ends, a process which included several hours of baking. This is out, for high-speed automatic production, and it was decided to apply a thin layer of the noble

metal, gold. To do so, and to do it in the time which could be allotted to this part of the job, required a machine almost as complex as the sealing machines used in making vacuum tubes. There are no less than 36 of the bell-jar "stations" in the machine shown on the cover.

When the resistors are ready for terminating, the carbon has already been deposited. They are then held in masks—disc-shaped objects through which one end of a resistor can be seen projecting in the cover picture—under a bell-jar from which all the air has been pumped, and a very low-pressure atmosphere of argon substituted. Disc-shaped gold cathodes above the resistors are used to supply the gold, which is actually eroded, or "sputtered" off the metal onto the ends of the resistors. A high voltage at low current (1,500 to 3,000 volts at 20 to 50 milliamperes) is applied to the cathode, and small particles of gold are knocked loose from the surface of the cathode by impinging argon ions and deposited on the resistor ends.

About ten-millionths of an inch of gold is deposited on the carbon. The discharge of high-voltage electricity is

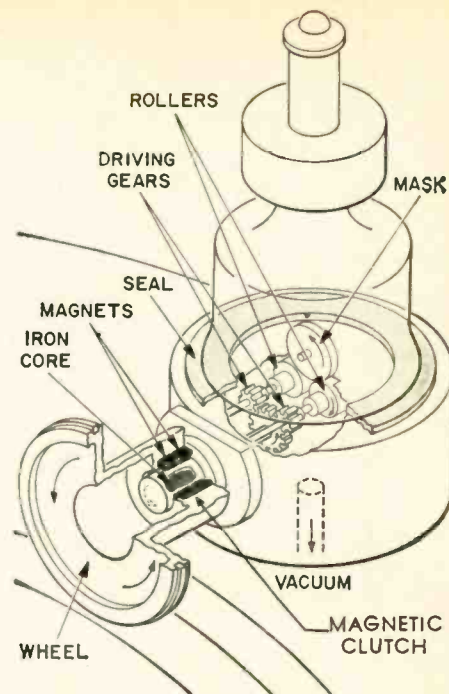

Actual assembly-line unit, showing how it is rotated for even coating.

what creates the flickering reds and purples inside the tube.

The gold that doesn't reach the resistors is deposited inside the bell-jar and has to be removed periodically. The gold deposited inside the glass can also be seen in the cover picture.

The caps to which the resistor's wire leads are attached are also flashed with gold. They are put on the resistor on a machine that caps both ends at the same time, with enough force to weld the gold plating of the cap to the gold on the ends of the core. This makes about as low-noise and reliable a contact as is possible to design.

Only one more operation is needed to make a full-fledged resistor out of our carbon-coated core. Enough of the carbon must be removed to give it a precise value. This is done on a helixing machine, which cuts a spiral from end to end of the resistor, removing the carbon from a spiral strip. Only one or two turns may be cut for a low-resistance unit, leaving most of the carbon on the resistor. More turns are cut for higher ohmages, till for very high resistance units only a narrow several-turn spiral of carbon remains on the unit. A computer-controlled bridge balances when the desired resistance is reached, disengaging the lathe which removes the carbon. The bridge also senses any non-linearity that would be caused by chipping or thin spots in the carbon coating, and rejects any resistors showing such faults. The computer control also rejects any resistor that reaches its value before 75% of its length is used, or fails to reach the value in the full available length.

Only finishing operations, such as placing the resistor in its insulating coat, checking it for leaks, etc., are required, once it has left the helixing machine.

END

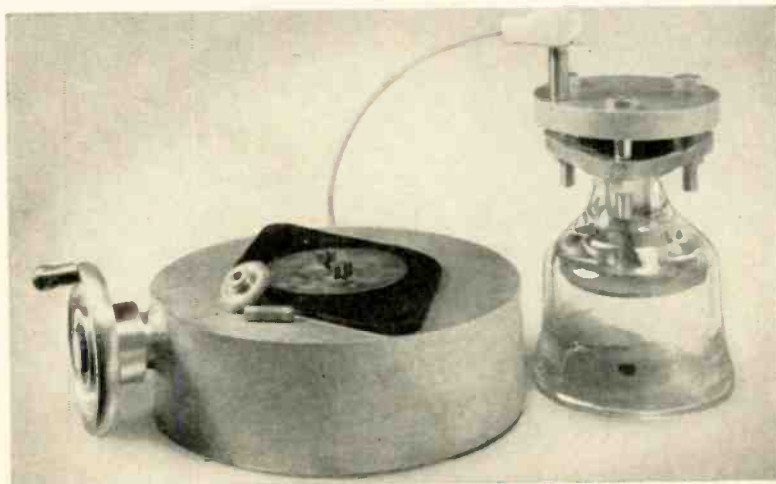

A prototype unit. The disc cathode can be seen in a bell-jar at right. The mask and a sputtered resistor are lying on top of the base. In the actual machine, the hand-wheel at left is replaced by a rubber-tire wheel, which rolls along a track to rotate the resistor and mask while being sputtered.

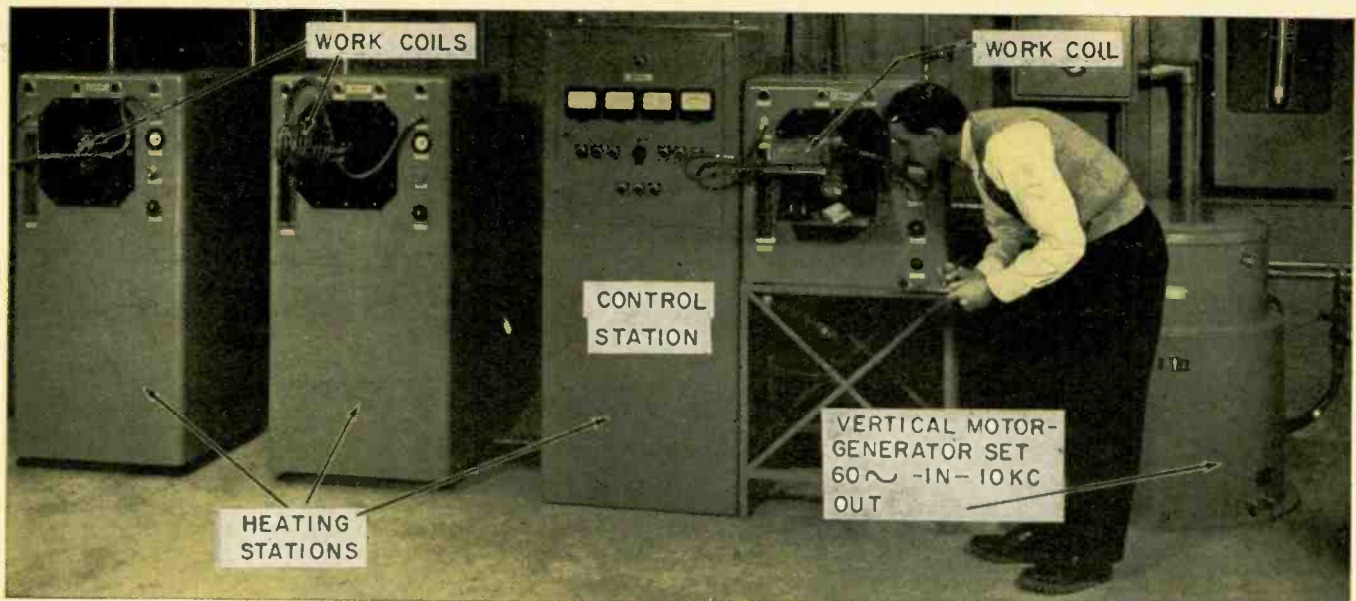

Photos by Robotron

# induction heating turns the trick

*How would you handle this job—heat only the threads on a steel shaft*

**By DELLROYE D. DARLING**

You are an industrial electronic technician. Or maybe you're a methods engineer. (This is a high-class term for a jack-of-all-trades.) The boss comes to you with a problem. He says, "Sam, we've got two hundred thousand shafts, and each one has a threaded section on one end. In the machine where these shafts will be used, a nut will be constantly running on and off the threads. We'll have to harden the threads so they don't wear out".

You know how to harden steel. You heat it up to a red heat, and then plunge it in a "quench" bath to cool it quickly. In some operations it doesn't matter too much how you heat the steel. You can use an oven, or a direct flame,

or any other method. But your boss is a mindreader.

He says, "We've got to do this hardening real quick, to make money, and we can't use an open flame because the steel will absorb carbon from it and become brittle. Besides, a flame will probably heat too deep and change the character of the steel in the core of the shaft, which has to stay tough."

Now you know! If you can't use a flame or an oven, and you want lots of heat real quick, there is only one answer: induction heating! Being a good electronics man, you know that induction heating will allow you to heat these shafts quickly to the required temperature, and with this type of heating you can control not only the area to which the heat is applied, but also the depth. That will leave the core of the shafts unchanged after the hardening takes place.

So you tell the boss "Look, give me a day to check and I'll tell just what equipment you need".

Back in the cubby hole they call your office, you pull out a sheet of paper and lay out the problem.

1. You must heat only the part of the shaft that is threaded.
2. You must heat only the surface of the threads, so they will retain their strength.
3. You must do all this in a very short time.

With induction heating, No. 1 is no problem. You know that induction heating produces heat by passing elec-

tric current through the steel. However, no actual electrical connection is necessary to the work, because the currents (called "eddy currents") are induced in the work by an expanding and collapsing magnetic field produced by a coil placed around the work.

Heat will be produced only where these eddy currents flow, and they will be confined to the general location of the work coil. By shaping the coil correctly, considering the shape and size of the work, heat will be produced only where you want it.

No. 2 on the list isn't a serious problem either. "Skin effect" that causes so many problems in high frequency ac circuits is an ally in the induction-heating business. High-frequency ac currents tend to flow in the

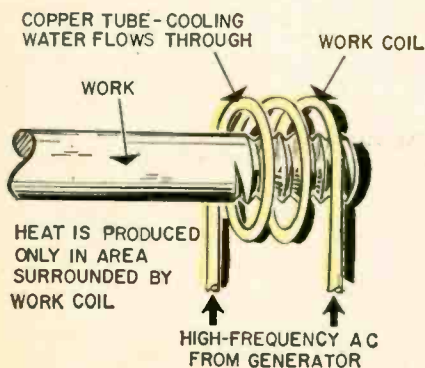

Physical arrangement of the heating coils and the work to be heated.

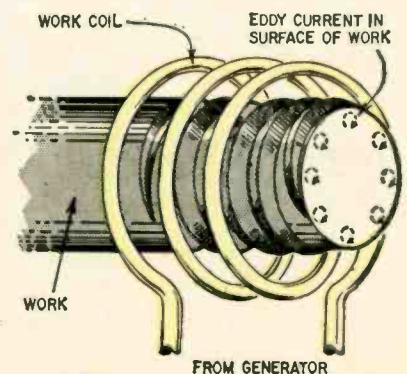

At higher frequencies eddy currents flow only in the surface of the work.



surface of a conductor. The higher the frequency, the closer to the surface the current will flow. The same is true for the eddy currents induced in the work by an induction-heating work coil. So, all you have to do to control the depth of heating is select a suitable frequency. (Of course, if you apply the heat for too long, it will "soak" into the work, so time has something to do with depth of heat penetration, too.)

This "skin effect" is one of the big advantages of induction heating, especially for a job like this one at hand. Flame heating heats from the surface inward, but to heat the surface of a piece of work quickly, without allowing the heat to soak in, requires a very intense flame. If you apply this intense flame to something like these threads, the outer edges of the threads will likely burn before the root has a chance to heat. Induction heating will produce heat to the required depth over the entire surface of the threads, without burning.

### From theory into practice

So far you have solved the boss's problem in a theoretical sense. Now for the practical part: choosing a suitable machine for the job. There are several important factors that govern the type of machine to be used for a particular application. Let's make another list.

1. **Output frequency.** Induction heating is done with frequencies all the way from 60 cycles to 450 kc or even higher. The lower frequency machines are used to heat large masses to a considerable depth. High frequencies are used to heat small pieces, or for operations such as surface hardening, etc., that require shallow penetration.

Up to about 10 kc, the most satisfactory equipment is mechanical. Package motor-generator sets are available with outputs of up to 10 kc and power ratings as high as 1200 to 1500 kw. However, beyond 10 kc an ac generator must have so many poles, and run at such a high speed, use of a mechanical

generator becomes impractical.

When higher frequencies are required, vacuum tube oscillators are usually used. These are actually very simple oscillator circuits, although the control equipment used with them may be complex. Most large vacuum tube generators operate in the range of 400 to 450 kc, with output power up to 100,000 watts, or more.

This thread hardening job needs shallow penetration, so 450 kc will be about right. That means you will need a tube-type generator.

2. **Power output.** We already know the upper limits of output power for both types of generator. Now, what power will we need to heat these threads? Well, now we're into the economics of the problem. In induction heating, as anywhere else, kilowatts cost money, and quite a lot of money, too. When speed isn't important, a small machine, at a lower price, may fill the bill. But, in a production shop time is money, too. Usually, a larger capacity machine will more than pay for itself in time saved per unit produced.

These threaded shafts are small, but we need rapid heating both for shallow penetration and high-speed production. Ten kilowatts will probably be adequate, although a test run is usually the best way to determine the power required for a particular job. (Most of the companies that build this equipment have facilities for test runs, and are happy to make them.)

You will also have to make sure that adequate line power is available. A 10-kw tube-type heater will need about 20 kva of three-phase power, at 230 or 460 volts.

3. **Cooling.** High-power tubes such as those used in induction heating generators may be either air or water cooled. However, since water is used to cool the work coil, most generators use water-cooled triodes in the oscillator circuit. Our 10-kw unit will need about 5 to 10 gallons per minute to cool the

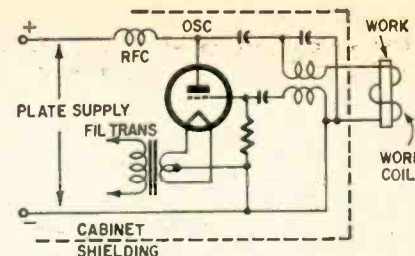

One type of induction heating generator circuit. This is a conventional feedback triode oscillator.

tube, plus some additional water for the work coil. You will have to make sure an adequate water supply is available at the work location.

4. **Controls.** Naturally, the generator unit will have to have fuse or circuit-breaker protection. But it will also need special safety devices, such as an automatic shutdown if the cooling water supply should fail. Protection against tube burnout caused by excessive grid or plate current, and safety interlocks to shut off high voltages when the cabinet is opened. The Federal Communications Commission requires proper shielding so the unit won't radiate interference.

All these requirements will be met by any unit made recently by a reputable manufacturer. Used equipment should be checked carefully to make sure it has proper protection and control facilities.

So, there is the answer to the boss's problem. He needs a vacuum tube generator with a 10-kw output, working at about 450 kc. It will need a water supply, and a three-phase power line. The work coil and material handling equipment will have to be specially designed for the job, of course, but the induction heater manufacturer will be happy to take care of that.

Well, another problem solved. Type it all on a sheet of paper and put it on the big man's desk EARLY next morning. If he's in the right mood maybe it will get you that raise. END

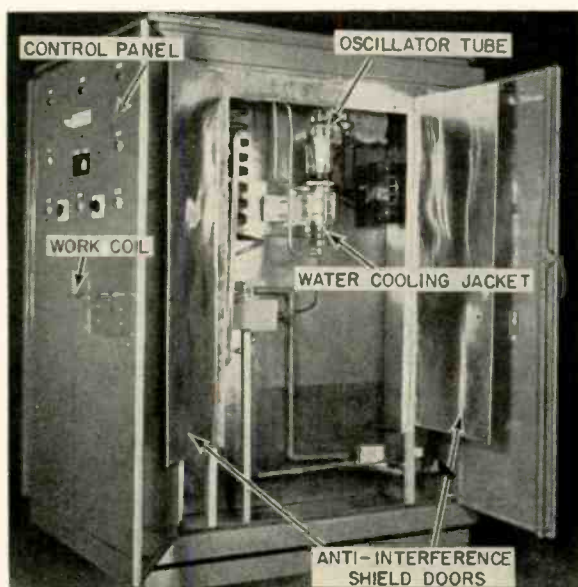

A 20-kw tube-type induction heating generator.

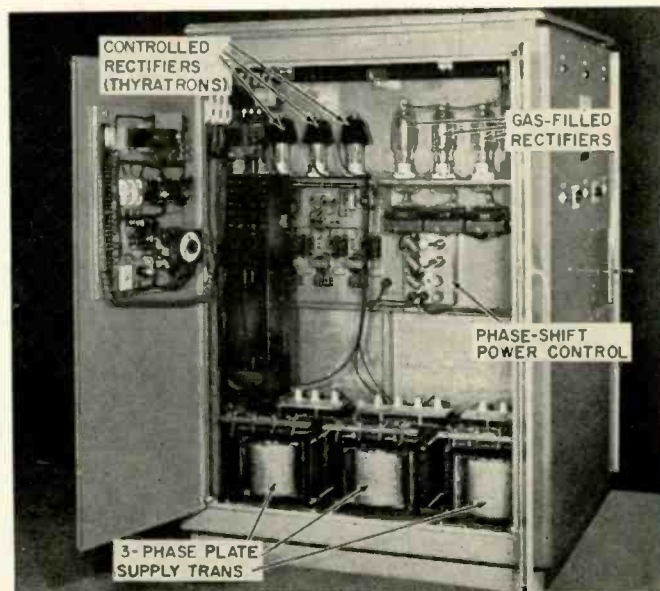

Rear view shows controlled 3-phase bridge rectifier used to adjust power output from generator circuit.

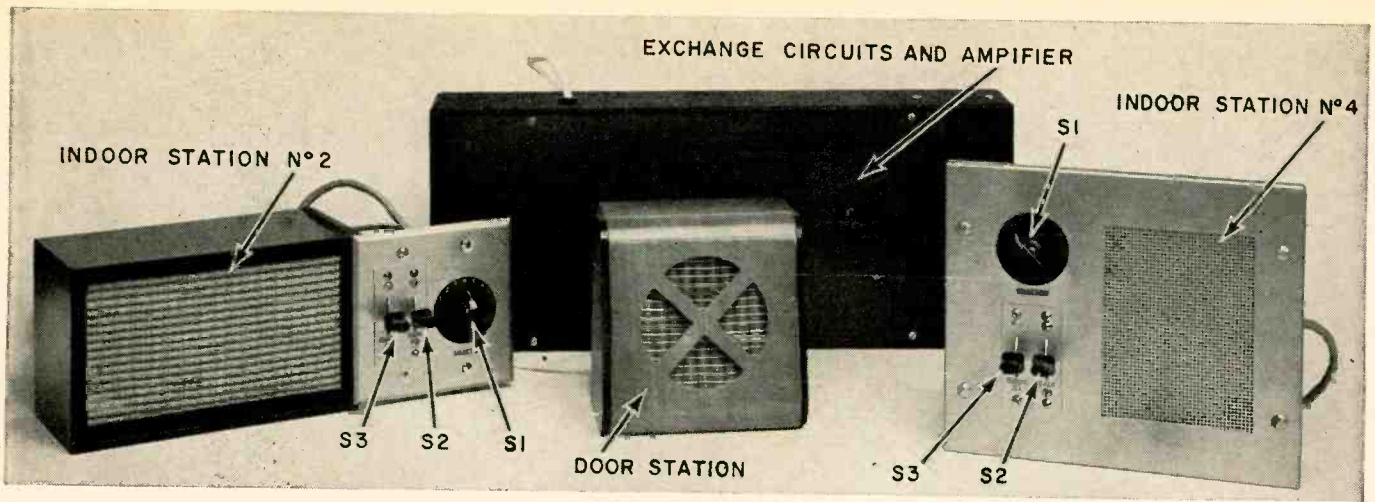

# 7-station intercom uses 1 master

**BUILD** *this all-transistor setup.  
Binary-type switching makes  
7-station, all-master system practical*

By **ROBERT D. HOCHBERG**

The two most disturbing problems in home intercommunication systems are that substations can't call other substations, and that most people just don't have the patience to wait for the amplifier tubes to warm up. The common and quite expensive solution to these problems has been to use all-master systems requiring multiconductor cables and ac sources at each station location, and to allow the five or more amplifiers to operate continuously. The intercom system described here solves these problems by combining the economy of the master-sub systems with the versatility of the all-master systems.

•It provides for calls between any

two of its seven stations. •It uses a single, transistor amplifier. •It partially solves the multi-cable problem with a binary type coded signaling system. •It provides for a station located outside the front door. •It needs no outside power, though the batteries may be replaced by a well-filtered power supply if desired. Even then, the unit will require ac power at only one location.

In purpose, this intercom is similar to "Intercom Super Duper Model I" (RADIO-ELECTRONICS, January 1961). In approach, however, the two are quite different. The Model I uses six vacuum tubes, three of which are in the relay exchange circuit. The proper connections are made through rather critical biasing of the relay control-tube grids.

My unit uses just four low-drain transistors—which draw current only when the unit is in operation—and an exchange circuit which has no tubes or transistors.

The heart of the system is a control cabinet containing the amplifier, exchange relays and batteries. It can be located in an attic, under a stairway or in just about any other accessible but out-of-sight location. One of the two batteries controls the exchange relays and the first two amplifier stages. The other battery controls only the output stage of the amplifier. With this arrangement, both batteries should last about the same length of time. Cables run from the control cabinet to each of the masters. Each master unit uses one speaker which doubles as a microphone, one two-pole seven-position selector switch, and two four-pole double-throw lever switches as function selectors.

## The binary exchange circuit

As shown in the schematic, the hot amplifier output lead is connected to the armature of RY1, an spdt relay. Depending on the position of the armature, the signal may be fed either to RY2 or RY3. (Since RY1 and RY2 are activated by the same signal, a single two-pole double-throw relay may be used instead.) From RY2 the signal may be sent to RY4 or RY5, and from RY3 it may be sent to RY6 or RY7. (Here a three-pole double throw relay may be substituted for RY4, RY5 and RY6). RY4, RY5, RY6 and RY7 channel the signal to masters 1,2,3,4,5,6 and DOOR. Thus, by energizing the proper

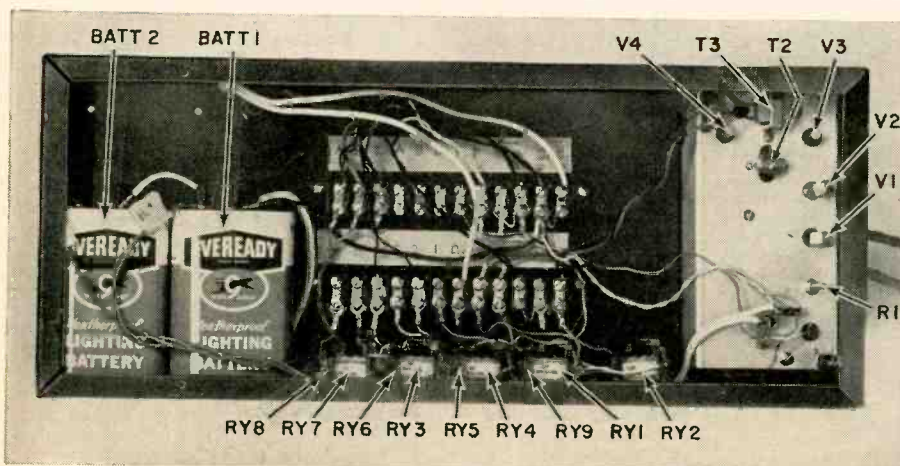

Switching relays and transistor amplifier are inside this case.

- R1—pot, 5,000 ohms
- R2—390,000 ohms
- R3, R5—4,700 ohms
- R4—330,000 ohms
- R6—2,700 ohms
- R7—100 ohms

All resistors 1/2-watt 10%

C1—100  $\mu$ f, 15 volts, electrolytic

C2—2  $\mu$ f, 15 volts, electrolytic

C3—10  $\mu$ f, 15 volts, electrolytic

C4—.05  $\mu$ f, 600 volts, ceramic disc

BATT 1, BATT 2—6 volts (NEDA 915, specify type with binding posts)

RY1, RY7—spdt sensitive relay (Sigma IIF-1000-G/SIL or equivalent)

RY2, RY3—spdt sensitive relay (Sigma IIF-1000-G/SIL or equivalent) (These two units can be replaced with a single relay bearing dpdt contacts.)

RY4, RY5, RY6—spdt sensitive relay (Sigma IIF-1000-G/SIL or equivalent) (These three units can be replaced with a single relay bearing 3-pole double-throw contacts.)

RY7, RY8—spdt relay sensitive (Sigma IIF-1000-G/SIL or equivalent) (These two units can be replaced with a single relay bearing dpdt contacts.)

\*S1—rotary switch, 2 poles, 7 positions (Mallory 3229J or equivalent)

\*S2—lever switch, 4 poles, double throw (Centralab 1457 or equivalent)

\*S3—lever switch, 4 poles, double throw (Centralab 1457 or equivalent)

T1—output transformer; primary, 2,000 ohms; secondary, 4 ohms (Universal output transformer used in reverse)

T2—driver transformer: primary, 10,000 ohms; secondary, 2,000 ohms, ct (Lafayette TR-98 or equivalent)

T3—output transformer: primary, 400 ohms, ct; secondary, 3.2 ohms (Lafayette TR-109 or equivalent)

V1, V2—CK722

V3, V4—2N109

\*Speaker, 3.2 ohms, 5-inch diameter

Speaker, 3.2 ohms, 5-inch diameter (for door station)

\*Case, for remote station, 7 x 5 1/2 x 3 inches (Lowell P35X or equivalent)

\*†Panel, for remote station, 8 3/4 x 7 1/4 inches (Lowell CSXD or equivalent)

†Case, for door unit, 7 x 5 1/2 x 3 inches (Lowell P35X or equivalent)

†Panel, for door unit, 8 3/4 x 7 1/4 inches (Lowell CSRX or equivalent)

Chassis, for amplifier, 1 1/4 x 6 1/2 x 3 inches

Case, for amplifier and relays and batteries, 16 x 6 1/2 x 3 inches or larger

\*For each indoor remote you will need one of each of these components.

†These units are made by Lowell (Lowell Mfg. Co., 3030 Laclade Station Rd., St. Louis 17, Mo.) as well as other manufacturers. The units specified have a brushed-brass finish. A variety of other arrangements are available, in assorted colors. It might be wise to get the manufacturers catalog and select units to suit your decor.

**Circuit of the intercom amplifier, switching circuits, a remote station and the door station.**

exchange relays, the output signal may be fed to any desired station.

Now let's assume someone at Station 4 wants to call someone at Station 6. He sets his selector switch to 6 and depresses his talk button. Three things happen: First, his speaker is connected across the input of the amplifier and disconnected from its normal position on its output relay. Second, P is grounded, energizing the two relays which supply current to the amplifier. Finally, leads A and C are grounded through the selector switch, activating RY1, RY4, RY5 and RY6 in the control cabinet. These channel the output of the amplifier to the speaker of Station 6.

If the doorbell rings, the person answering switches the nearest station to 7 and depresses the talk button to be heard outside the front door. To hear a reply, he has merely to push his DOOR MONITOR button. This sends power to the amplifier, connects his speaker through the exchange relays to the amplifier output, and connects the door station through RY7 to the amplifier input. The DOOR MONITOR button eliminates the need for any controls on the front-door unit.

By now you should be familiar enough with the switching circuit to

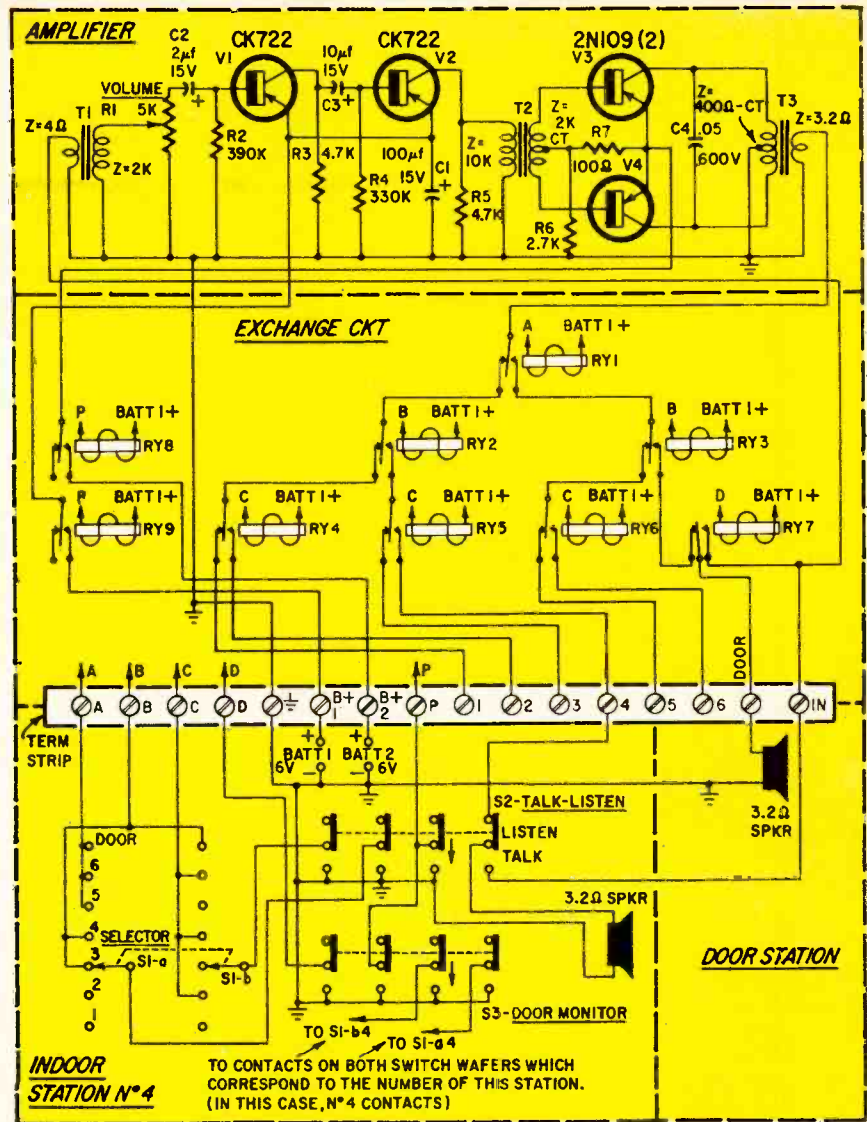

see that only one two-way conversation can be handled at a time. However, this disadvantage is balanced by the facts that only eight-conductor cables are needed from the masters to the control cabinet, and that there is only one amplifier to power.

The greatest advantages of the binary exchange circuit are in a system with many stations. This 7-station system requires 3 wires to operate the exchange relays. A 64-station, all-master system would require only 6 wires to

operate the relays. There is, though, a practical limitation—a 64-station system would require 63 spdt relays.

**Transistor amplifier**

The four-transistor amplifier uses CK722's for the first two stages and 2N109's in the push-pull output circuit. Its reproduction fidelity is equal to that of most three-tube intercom amplifiers. (If desired, the unit can be made into an interesting and good-sounding phono amplifier simply by removing the input

Closeup view of the underside of the amplifier chassis.

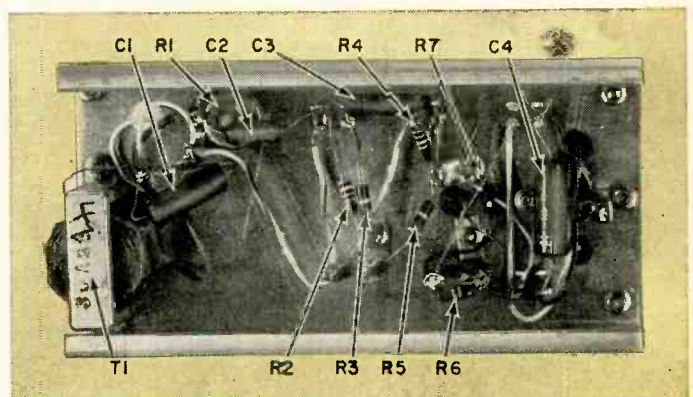

transformer and connecting a magnetic cartridge in its place.)

The amplifier is built on a 1¼ x 6½ x 3-inch aluminum chassis which is placed in the control cabinet after assembly. Follow the schematic, keeping output leads as far as possible from the input. Mount the transformer cores at right angles to one another to minimize inductive feedback. Be careful when soldering to the transistor sockets. Beads of solder may form between the closely spaced prongs.

Use heavy wire (preferably two lengths of No. 18 run parallel) in the circuit connecting the amplifier to BATT 2, and keep BATT 2 as close to the amplifier as possible. The use of light wire or an attempt to use just one 6-volt battery may cause the amplifier to oscillate.

Bend the relay springs a little so the relays will pull in even after the batteries start weakening. Mount all relays on an insulator such as wood or Plexiglas. Because their armatures are internally connected to their mounting brackets, assembling the relays on a metal chassis would, in effect, connect all the armatures together. As was stated earlier, dpdt and three-pole double-throw relays may be used instead of the parallel spdt units. However, multicontact relays as sensitive as the spdt types used here (50 mw) are expensive.

All connections to the control cabinet are made by running the cables in through holes in the top and fastening them to the barrier strips inside. Two adjacent terminals should be used for each of the A, B, C, D, P and input and ground wires to reduce congestion at the barrier strips. Leads from the relays to the amplifier are routed by way of the terminal strip to facilitate later removal of relay bank or amplifier. END

### DUAL CATHODE FOLLOWER

Sometimes we need a way of reversing the polarity of a low-impedance signal or supplying two equal signals 180° out of phase from low-impedance sources. Here is a circuit from *Revista de Informacion Electronica* (Madrid, Spain) that does the trick.

Phase relationships are shown on

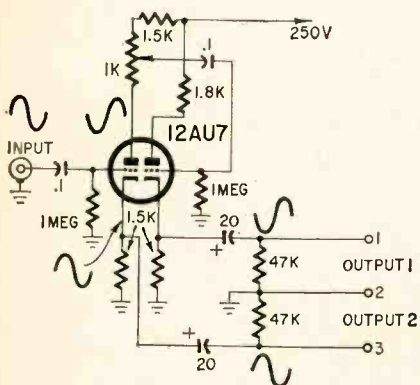

the diagram. The input triode is a phase splitter and cathode follower. The 1,000-ohm potentiometer is used to balance the outputs. Balance can be checked with an audio vtm or scope.

# SW PROPAGATION FORECAST

May 15-June 15

By STANLEY LEINWOLL\*

Scientists of the Central Radio Propagation Laboratory (CRPL) of the National Bureau of Standards have after 5 years of research, successfully applied digital computer techniques in preparing the world contour maps that are used to predict short-wave radio propagation conditions.

These new methods, which will be available for general use in several months, are expected to increase the accuracy of high-frequency propagation predictions. The data in the tables below, derived from the basic contour maps published regularly by the CRPL, show the optimum frequency in megacycles for propagation of short-wave signals between the locations shown during the time periods indicated.

To use the tables, select the one most suitable for your location, read down the left side to the region in which you are interested, then follow the line to the right until you are under the appropriate time. (Time is given at the top of each table in 2-hour intervals from midnight to 10 pm, in your local standard time.) The figure thus obtained is the optimum working frequency, in megacycles. The best band for the particular service in which you are interested is the one nearest the optimum working frequency.

For example, a resident of San Francisco would use the Western USA table. At noon, Pacific Standard Time, signals to and from the Far East would be optimum in the 13-mc band. A radio amateur would be most likely to establish communications in the 20-meter (14-mc) band, while a listener would first try the 11-mc broadcast band, and follow this with the 15-mc band.

The tables are designed to serve primarily as a general guide, since day to day variations in receiving conditions can be considerable. At certain hours, propagation over some of the paths given in the tables may be extremely difficult, or impossible. This will depend on the type of service, antenna characteristics, radiated power of the station, etc. The curves from which the data in the tables is derived are based on an effective radiated power of 10 kw.

### EASTERN US 10:

	Mid	2	4	6	8	10	Noon	2	4	6	8	10
West Europe	8	8	8	10	11	12	12	13	13	13	12	10
East Europe	8	8	8	9	10	11	12	12	12	11	9	8
Central America	12	10	11	13	15	15	16	17	16	15	14	13
South America	12	9	12	15	17	17	17	17	17	16	14	13
Near East	8	7	8	10	11	12	12	13	13	12	11	10
North Africa	8	7	8	11	12	13	13	14	14	14	12	10
South & Central Africa	7	9	10	13	15	16	16	16	15	14	8	8
Far East	9	8	8	8	10	11	11	11	12	12	11	10
Australia & New Zealand	12	11	11	10	10	10	9	15	18	18	18	15

### WESTERN US 10:

West Europe	8	7	9	11	12	12	12	13	13	11	10	8
East Europe	8	8	8	11	11	12	12	12	11	10	10	10
Central America	13	11	10	13	15	15	16	17	17	16	15	13
South America	9	10	15	16	17	17	17	17	15	14	13	13
Near East	8	9	10	11	12	13	13	13	11	11	9	9
North Africa	7	9	11	12	12	13	13	13	12	11	10	8
South & Central Africa	8	10	12	13	13	14	14	15	15	13	10	8
Far East	9	7	9	12	11	12	13	13	13	14	13	11
Australia & New Zealand	12	12	10	10	10	16	18	19	18	17	13	13

### CENTRAL US 10:

West Europe	8	8	8	10	11	11	12	12	11	10	9	9
East Europe	7	7	7	8	10	10	10	10	10	9	9	9
Central America	13	11	12	15	17	18	19	19	19	18	15	13
South America	10	8	10	15	16	17	17	17	16	16	14	12
North Africa	7	7	8	10	11	12	12	12	12	11	10	9
South & Central Africa	9	8	10	13	13	14	14	13	11	8	8	9
Far East	13	13	9	9	12	12	13	14	14	14	14	14
South Asia	12	9	8	9	12	12	12	12	12	13	13	13
Australia & New Zealand	13	13	11	10	10	14	19	20	20	20	20	16

\*Radio-frequency and propagation manager, RADIO FREE EUROPE.

# MORE circuits for FM STEREO

By NORMAN CROWHURST

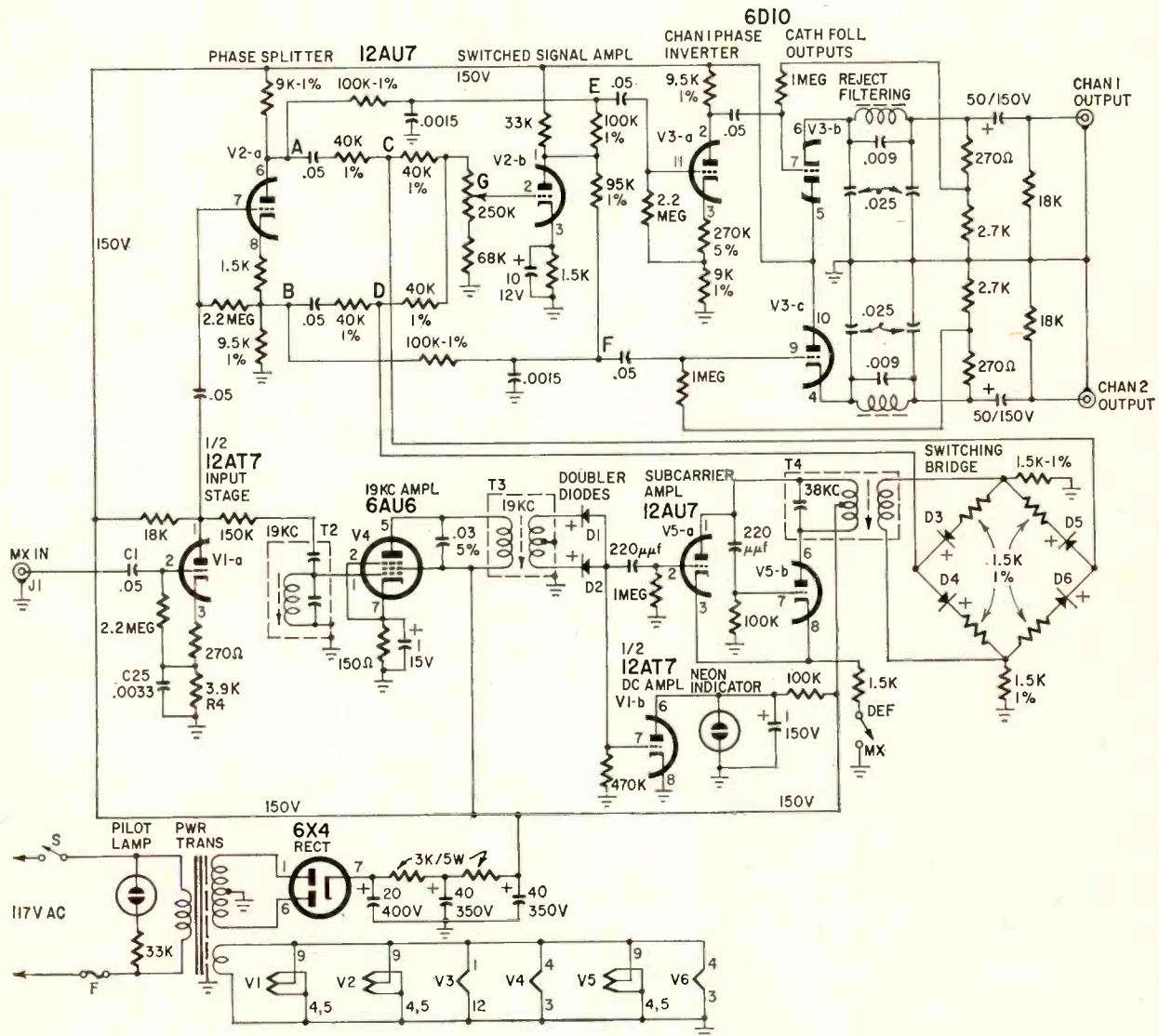

THE HEART OF THE EICO MX99 IS A MODIFIED "switching" circuit. First the input is fed to a stage giving about 13.5-db gain with an input impedance of about 10 megohms. C25 provides compensation at the extreme high end (from 20 kc up). C1 isolates the dc voltage due to R4. The composite signal is fed to V2-a, a phase splitter, to produce anti-phase signals at A and B. The 19-kc pilot is separated by T2 and amplified by V4. Then it is frequency-doubled by D1 and D2 connected to T3's secondary to produce a pure 38 kc.

This is amplified by V5 and fed to the switching bridge through T4. The switching bridge short-circuits points C and D to ground during alternate half-cycles of the 38-kc regenerated subcarrier. So the grid of V2-b (G) is fed with composite signal, reversed in phase every half-cycle of the 38-kc subcarrier.

Here it is amplified and combined separately with the voltages at A and B, to produce left and right

outputs at E and F. When the bridge momentarily short-circuits point C, the signal fed to V2-b grid comes from point B. When this is phase-reversed (in V2-b), it will cancel the signal directly from B to F, so that F has zero output, while E receives an augmented output during this half-cycle of 38 kc.

The nulling action at points E and F also nulls the 67-kc SCA (Subsidiary Communications Authorization) subcarrier if it is present, without any need for a frequency-selective filter. V3-a is a phase inverter to reverse the phase of output E, because the two channels are in phase opposition at E and F. V3-b and V3-c are cathode-follower outputs, with filtering included to reject the switching products resulting from combining A, B and amplified G (which is square-wave switched) at E, F. The voltage change on D1 and D2 when 19 kc is present is used to change the bias of V1-b and thus light the neon to indicate that stereo is being received.

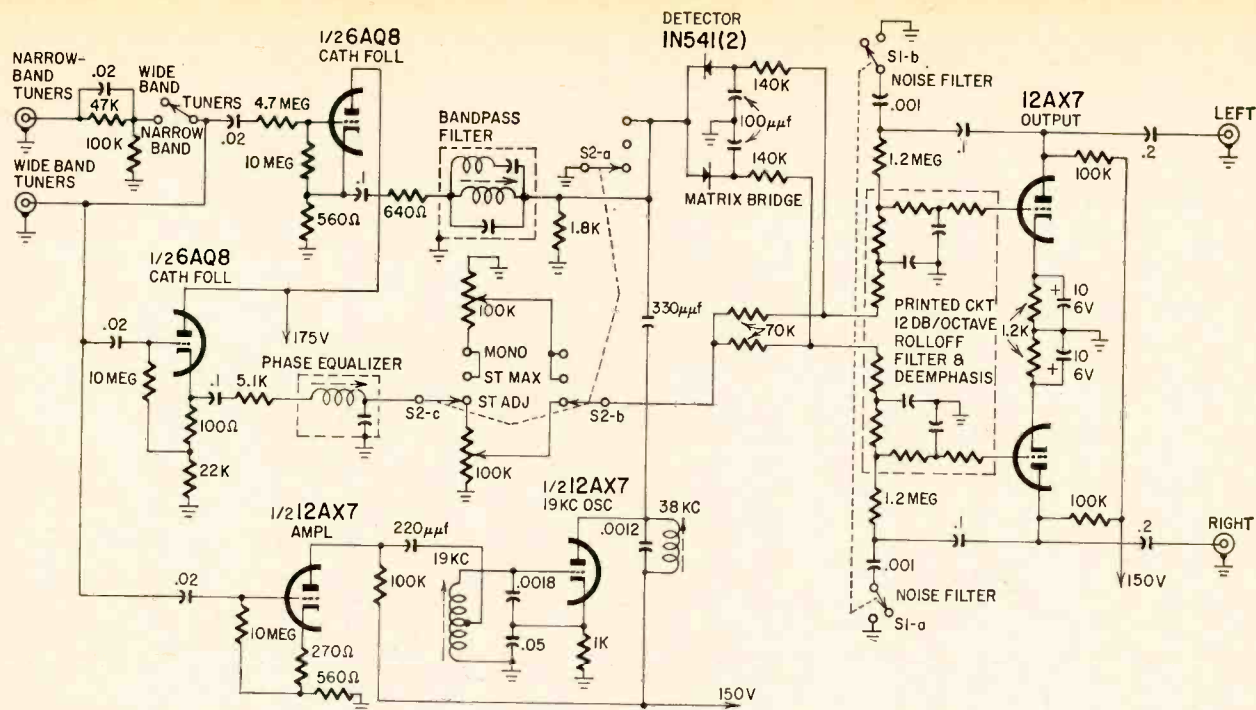

THE PACO MX100 HAS INPUTS with and without compensation, to accommodate narrow- or wide-band tuners. The input then feeds three stages in parallel, two cathode followers and an amplifier. One of the cathode followers feeds a low-pass filter with phase equalization or adjustable response. The

other feeds a bandpass filter to select the L-R sidebands. The amplifier stage locks the 19-kc oscillator, which has a 38-kc tuned circuit in its plate. This plate is capacitance-coupled to join the output of the bandpass filter in feeding oppositely phased diodes to demodulate the L-R signal. The low-pass

filter terminates in a semi-fixed or a fully adjustable separation control that varies the L + R fed to the matrixing bridge. The outputs from the matrixing bridge feed the grids of the output amplifier stages through printed circuit filters providing de-emphasis and 12 db/octave rolloff (above 15 kc).

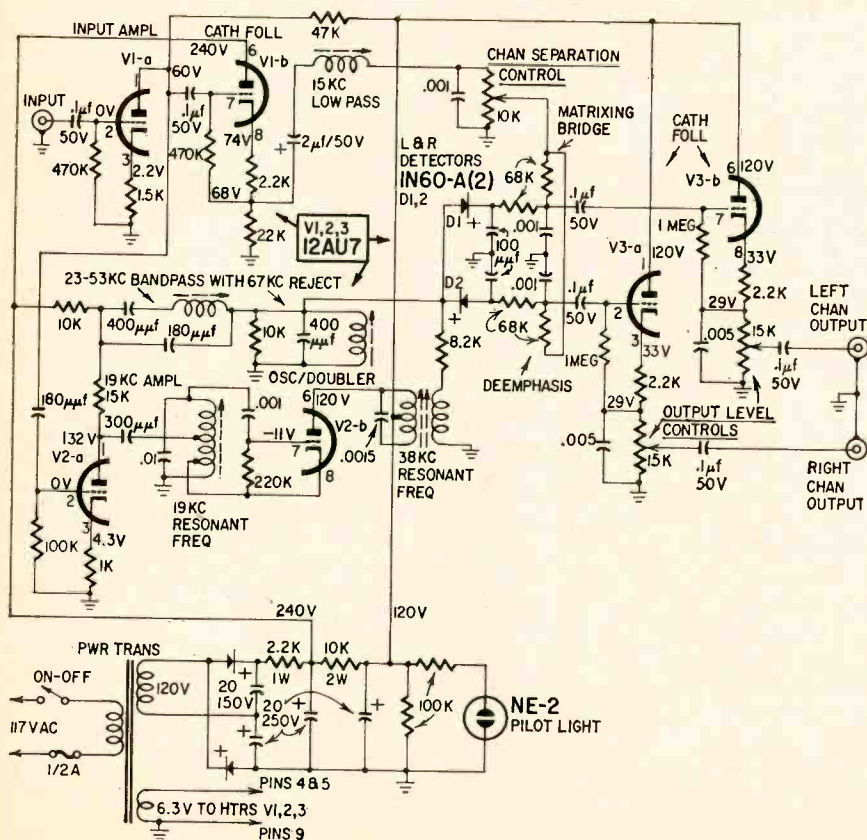

HEATH'S AC-11 ADAPTER HAS A conventional linear input amplifier stage, which feeds a further amplifier stage for the 19-kc selector circuit, and a cathode follower to feed the composite audio into its matrixing arrangements. The further amplifier stage synchronizes a 19-kc oscillator, whose plate circuit has a 38-kc tuned-circuit transformer, coupling into the L-R detector circuit. The output from the cathode follower feeds a low-pass filter (15 kc) with a separation control on its L + R output, and also a bandpass filter with SCA reject of conventional design, also feeding into the L-R detector circuit. This uses oppositely phased diodes which feed the matrixing bridge. Mixes of L + R and L - R from the matrixing bridge feed the cathode-follower outputs. A capacitor directly across each bridge output provides de-emphasis.

SWITCH POSITIONS	
S1	FILTER SWITCH
1	OFF (SHOWN)
2	AC OFF (SHOWN)
3	TUNER
4	STEREO-MONO AUTOMATIC
	STEREO MANUAL

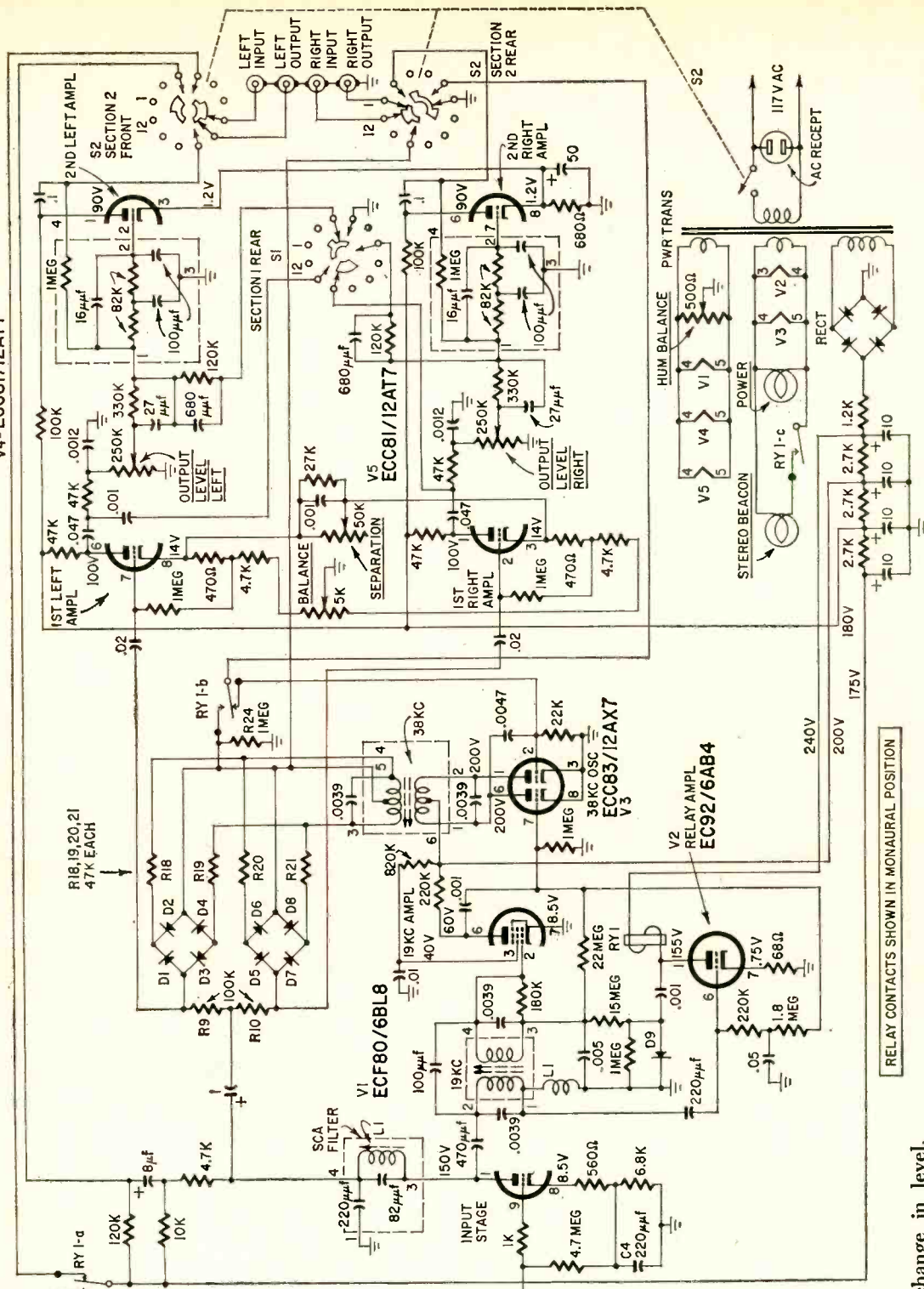

**FISHER'S MPX-100 ADAPTS** for different input levels with dual inputs. Each presents an impedance better than 20 megohms. The voltage divider is capacitance-compensated by C4. Gain of the first stage is increased about 4 db for stereo listening by relay contacts RY1-a to avoid an apparent change in level. The plate-circuit input stage (triode section of V1) filters out SCA in coil L1. The 19-kc pilot is fed to the pentode section, which applies it to synchronize V3, the push-pull 38-kc oscillator. At the same time, changes in operating conditions due to the 19 kc, alter bias on V2, triggering relay RY1. With S2 set to STEREO-MONO AUTOMATIC, contacts RY1-b short one grid of oscillator V3 in mono, leaving the switching-bridge ground connection "open" (through R24).

In stereo, the same contacts short the right side of the bridges to ground and allow the oscillator to operate, delivering a switching voltage through current-limiting resistors (R18 through R21) to the bridges. This short-circuits the signal fed through R9 and R10 to V4 and V5 on alternate half-cycles, separating left and right to these two channels. Common-cathode connections, with adjustments, provide separation and balance control. After level controls, feedback filter-

ing over the second half of V4 and V5, right and left output is delivered to the output jacks. The switching is such that, in the "off" position (shown), left and right inputs are connected directly to left and right outputs.

For mono, opening the ground connection at the right side of the bridges stops the switching operation, and allows the same signal to be fed to both V4 and V5 simultaneously, through R9 and R10.

# JUMPING TO CONCLUSIONS

Twelve ways to use jumpers to speed TV repairs

By MIKE WAYNE

EXPENSIVE TEST APPARATUS IS NEEDED for many jobs in the TV service shop. Sometimes, though, properly used inexpensive equipment is faster and more accurate than the electronic wonders. This is true of the jumper wire, not very expensive at best, but a most versatile piece of test equipment. Besides the obvious uses of substituting parts, connecting test speakers, etc., there are many other ways to use this piece of wire with a clip on either end. Let's look at a few examples.

## No high voltage

The horizontal amplifier tube is red hot. You suspect the oscillator, but is it the primary cause? A faulty phase-detector circuit could be causing the oscillator to run off frequency or not at all. Take a jumper and ground the sync input grid (Fig. 1). High voltage come back on? Then you have trouble in the phase detector. Better check the diodes or coupling capacitors. (Incidentally, you can ground the grid from the top

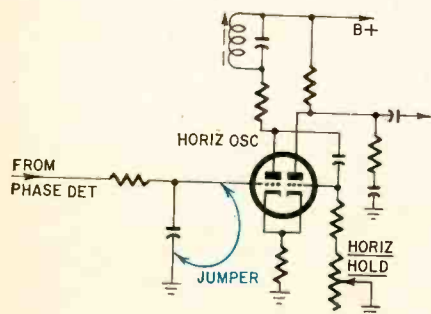

Fig. 1—Jumper divides the circuit. Determines whether phase detector is causing oscillator malfunction.

of the chassis if you use a test adapter socket.)

## Unstable horizontal oscillator

Let's now suppose you have a horizontal oscillator (multivibrator) that tends to take off; drops out of sync at the slightest provocation or wiggles, jiggles or otherwise cuts up. Better check to see that the oscillator circuit is adjusted properly. How? Connect a jumper across the ringing coil. Connect another from the sync input grid to ground. Now adjust the horizontal hold control until the picture floats by slowly. Remove the jumper from the ringing coil. Adjust the ringing coil until the picture again floats by. Remove the jumper from the sync input grid. Unless you have troubles in the circuit, the oscillator should now work perfectly. If the oscillator quits working with a jumper across the ringing coil, increase the size of R in Fig. 2 to 10,000 ohms and leave it in the circuit.

## Horiz oscillator squegging

Let's say you have a gunboating

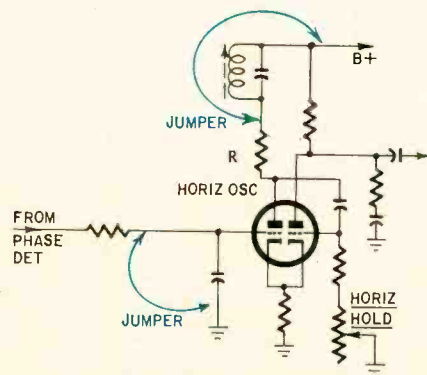

Fig. 2—Horizontal multivibrator adjustment is simplified with two jumpers.

(squegging) Synchronguide horizontal oscillator. You're in the home with no scope. You can make a fairly satisfactory adjustment with the help of a couple of jumpers.

Remove the sync signal by grounding it out with a jumper. (The grid of the sync clipper tube is usually a good place.) Connect another jumper across the phase coil (L2 in Fig. 3).

Adjust the horizontal frequency slug (L1) until the picture floats by (center the resistance control if there is one). Now remove the jumper from across the phase coil and adjust the phase coil until the picture again floats by. Unground the sync circuit. If the oscillator and control have no defective parts, the picture should lock in with virtually no instability. If it doesn't lock in you can start looking for defective components.

## Got a sync problem?

The sync clipper is one of those combination sync clipper and noise-cancelling circuits using a 6BU8, 6CS6, etc. You realize that the trouble could be something in the noise-cancelling cir-

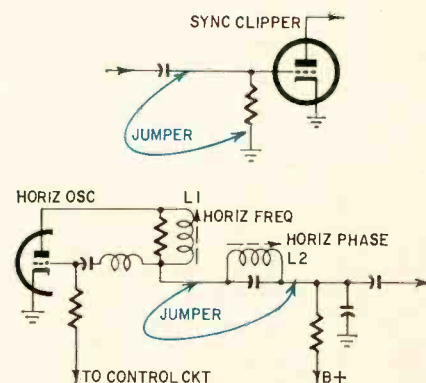

Fig. 3—Emergency adjustment of Synchronguide without a scope.



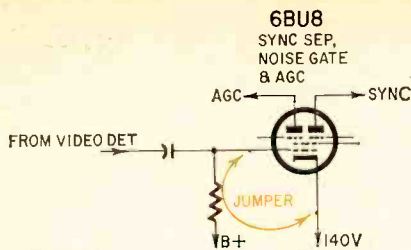

Fig. 4—Disabling the noise clipper.

cuit. How will you find out? You guessed it, a jumper! Connect it from the noise grid to cathode as shown in Fig. 4. This disables the noise canceller. If the sync still acts up, then you can concentrate on the sync-clipping portion of the circuit.

#### No agc voltage

It's a keyed agc circuit. Use a jumper here? Sure! Connect it from the grid

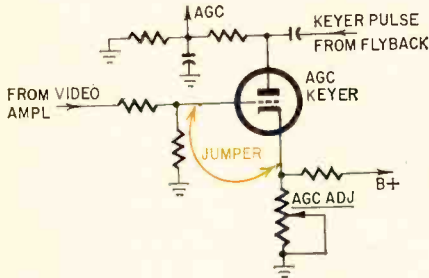

Fig. 5—Artificially keying an agc tube.

of the keyer to the cathode, as shown in Fig. 5. This zero-biases the keyer and you should have several volts negative on the plate of the keyer. If you don't, you have trouble in the keyer tube circuits, or else the keyer pulse isn't reaching the plate. On the other hand, if you *do* have negative voltage now, it's a sure sign that you have trouble in the biasing circuit and you know which way to look.

#### Sound bars

When you turn up the volume, do sound bars appear in the picture? Connect a jumper across the speaker voice coil (Fig. 6). Why? This will kill the speaker output. If you still have sound bars, you know it is probably improper bias or filtering in the audio circuits.

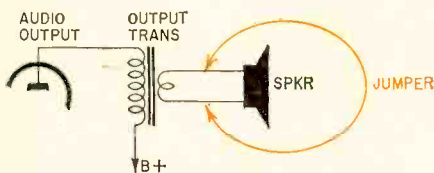

Fig. 6—Isolating the cause of sound bars.

If the sound bars are diminished, then something is loose or a tube is microphonic and the sound from the speaker is disturbing it.

#### Snowy picture

This is often caused by excessive (negative) agc voltage to the tuner because of an open delay resistor, R in Fig. 7. Check for this by connecting a jumper from the tuner agc terminal to ground. Clear the trouble? Then you

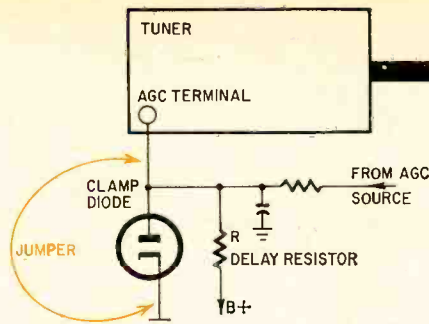

Fig. 7—Grounding agc to check delay resistor.

have excessive agc. Still snowy? Then the trouble is in the rf amplifier circuit or antenna.

#### No vertical deflection

Is it in the output stage or the oscillator? A jumper from the heater winding (hot side) to the output grid will produce deflection (distorted though it

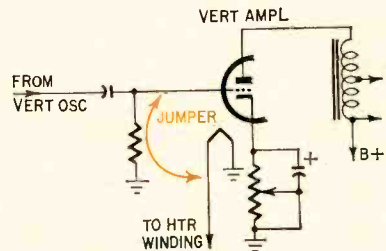

Fig. 8—Checking vertical output stage. is) if the output stage is operative (Fig. 8).

(In circuits where the bias would be upset drastically by a direct jumper, use a 0.25- $\mu$ f capacitor in series with the jumper or, better still, make up a capacitor jumper.)

#### Bright vertical bars

They're in the raster. Is it sweep trouble or are they being introduced into the video? A jumper tells you which. Simply short out the video input (Fig. 9). If the raster clears, you know you have either trouble in the video circuit or radiation from an unshielded flyback circuit. If the lines don't go

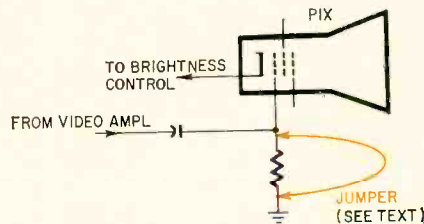

Fig. 9—Checking video troubles.

away, you have a horizontal sweep problem. Maybe a ringing yoke.

#### Fixed brightness

The brightness control has no effect. The picture tube checks OK. A jumper

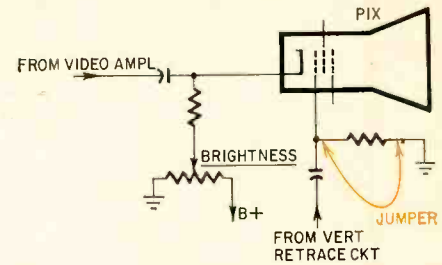

Fig. 10—Checking to see if retrace circuit is causing brightness control malfunction.

from grid to ground in the circuit of Fig. 10 will eliminate the vertical retrace circuit as a source of trouble. (It's often caused by a shorted capacitor in that circuit.)

#### Distorted sound

You suspect a leaky coupling capacitor—C in Fig. 11. You'd like to check it without disconnecting it first. Place a meter across the cathode resistor. Now ground the control grid with a jumper wire. Voltage go down? The capacitor

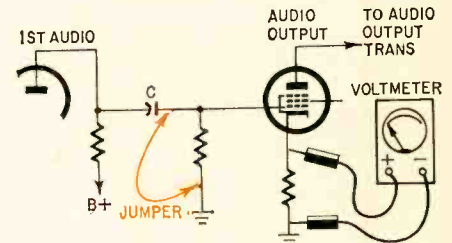

Fig. 11—Checking for leaky coupling capacitor.

is defective (leaky) since it is obviously causing the tube to draw more current.

#### High-voltage shock

Dislike getting shocked when you disconnect the picture-tube anode lead? This often happens even though you have shorted it out once or twice with a screwdriver. Connect a jumper, first to ground and then to the anode lead—you can't get shocked and even the most timid soul shouldn't be squeamish about removing the lead.

Of course this short article doesn't cover everything a jumper can be called upon to do (even a big book probably wouldn't hold all that could be written about the remarkable jumper), but it's a start—you take it from there. END

These simple jumper wires can save the technician a lot of time.

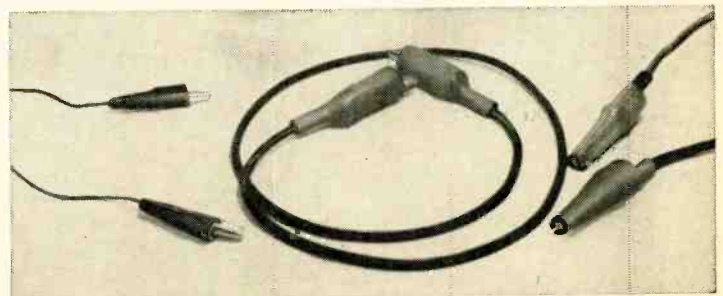

# STANDOFF!



Most people think Standoff means "keep your distance" ■ Any good Service technician knows a Standoff as a gadget to hold the lead-in away from the house ■ So... ?

Just this. Philco talks your language, Mr. Serviceman. We practically eat and sleep parts and service day in, day out—just like you! We know your problems intimately. We know that unless you make a profit, this Philco operation can never make a profit, either. Everything we offer must be of value to you.

This Standoff, for instance. It has been tested for heat . . . for cold. It is hot galvanized to be rust resistant, tested for tensile strength, for shear . . .

dozens of individual tests and inspections. It's typical of the pains that are taken to insure the quality of every part Philco makes or sells.

Look to Philco for Sales helps, Training aids, Programs, to help keep you the expert in your field. And look to Philco for parts that replace quickly and stay replaced. This means Quality! Your profits will follow as day follows night—and so will ours!

Standoffs, anyone?

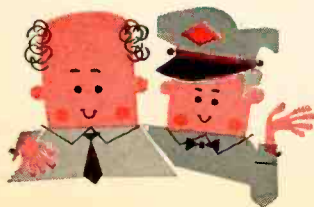

YOUR PHILCO DISTRIBUTOR has a complete selection of Philco tubes, Philco and universal capacitors, batteries, parts and accessories . . . for every service need. See him today!

PARTS & SERVICE OPERATIONS  
**PHILCO**  
A SUBSIDIARY OF *Ford Motor Company*

# RCA training at home can be the smartest investment you ever made

Look what you get in the Course in Radio and Electronic Fundamentals

**40 Fascinating THEORY LESSONS**



Containing all the basic principles of radio and electronics in easy-to-understand form

**40 EXPERIMENT LESSONS**



Each containing absorbing, practical experiments bound together in 20 books.

**40 SERVICE PRACTICES**

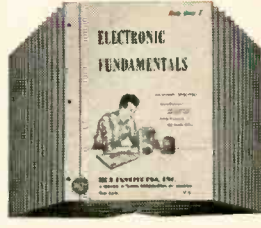

Full of practical, time-saving and money-saving servicing tips, bound into 20 books.

## PLUS ALL THIS AT NO EXTRA COST...

**15 KITS**

to build a Multimeter, AM Receiver and Signal Generator. Kits contain new parts for experiments, integrated so as to demonstrate what you learn in the lessons and to help you develop technical skills. Each kit is fun to put together!

**MULTIMETER**



A sensitive precision measuring instrument you *build* and *use* on the job. Big 4½" meter with 50 micro-amp meter movement. 20,000 ohms-per-volt sensitivity d-c, 6,667 a-c.

**AM RECEIVER**



Have the satisfaction of building your own radio receiver with this high-quality 6-tube superheterodyne set. Big 5" speaker, fine tone!

**SIGNAL GENERATOR**



A "must" for aligning and trouble-shooting receivers. Build it for your own use. 170 KC to 50 MC fundamental frequencies for all radio and TV work.

Also, comprehensive, fully-integrated home study courses in • *Television Servicing* • *Color Television* • *Automation Electronics* • *Transistors* • *Communications Electronics* • *Computer Programming*. Stake out your future in electronics with any one of this wide variety of courses.

Practical work with the very first lesson! Pay-only-as-you-learn! No long-term contracts to sign! No monthly installments required. Pay only for one study group at a time, if and when you order it!

SEND FOR FREE HOME STUDY CATALOG TODAY!

RESIDENT SCHOOL COURSES in Los Angeles and New York City offer comprehensive training in Television and Electronics. Day and Evening classes. Free Placement Service. Catalog free on request.



**RCA INSTITUTES, INC.**  
A Service of Radio Corporation of America • 350 W. 4th St., New York 14, N. Y. • 610 S. Main St., Los Angeles 14, Calif.

**RCA INSTITUTES, INC.** Home Study School, Dept. RE-62  
A Service of Radio Corporation of America  
350 West Fourth Street, New York 14, N. Y.

Without obligation, rush me the FREE 64-page illustrated booklet "Your Career in Electronics" describing your electronic home study training program. No salesman will call.

Name.....

Address.....

City..... Zone..... State.....

Veterans: Enter discharge date.....

**CANADIANS**—Take advantage of these same RCA courses at no additional cost. No postage, no customs, no delay. Send coupon to: RCA Victor Company, Ltd., 5581 Royalmount Ave., Montreal 9, Quebec.



The Most Trusted Name in Electronics

# SERVICE CLINIC

Conducted by  
**JACK DARR**  
SERVICE EDITOR

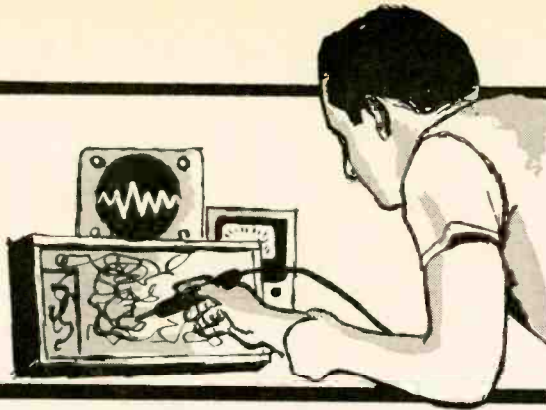

This column is for your service questions. We answer them free of charge and your name and address will be kept confidential if you wish. The main purpose is to help those working in electronics with their problems.

We've changed our target a little and are no longer restricted to TV. Radio, audio and industrial electronics problems are also grist for the mill. All letters get a prompt individual answer and the more interesting ones will be printed here. So if you have a service problem, send it here. We'll do our very best to help you solve it.

IF THE VERTICAL LINES AT THE TOP OF a TV picture pull to the right, you can bet that a service technician is going to see that set pretty soon. It is a minor complaint, but very annoying to viewers.

Fig. 1 is a drawing of a TV screen with a cross-hatch pattern and pulling to the right. Eight squares across the top of the picture, with a 53- $\mu$ sec scanning time per line, means about  $\frac{1}{8}$  of 53, or approximately 6- $\mu$ sec, to scan each square. The top line in Fig. 1 is late by about  $\frac{3}{4}$  of a square. If the trouble shows up as drawn, the next line is not quite as late, the next still closer to proper timing and, finally, after about 60 lines are scanned, the rest of the lines are on time.

If we connect a scope to the grid of the horizontal output tube through a low-capacitance probe and use the scope's internal sync, we'll see the familiar sawtooth or trapezoidal waveform of Fig. 2. Since the signal on the screen is the one which triggers the sweep inside the scope, a 6- $\mu$ sec delay won't show too much. The sweep will obligingly pull over to match it, and we'll still see a nice clean waveform, showing no signs of trouble.

If we could make the sweep absolutely constant with no variation, then we could detect the slowing down of the top lines of the raster. So, we use the scope's external sync input. For a reference sync signal, we can connect

to some point in the circuit where the station-signal horizontal sync is available; for instance, at the horizontal sync separator.

Now, with a stationary reference signal, the pattern will show up looking like Fig. 3. The 6- $\mu$ sec delay of the top lines will cause a displacement of the vertical lines of the pattern, and the typical thickening will show up.

This must be caused by some 60-cycle ac, since the trouble shows up at the top of the picture, every 1/60 second. If the signal causing the trouble is coming from the local 60-cycle power supply, pulling will appear in other parts of the picture at times. It is impossible to synchronize power-line frequency everywhere in the country. If the 60-cycle signal is coming from the station signal, in other words from the vertical sync pulses, then it usually appears at the top of the picture.

There are two possibilities: One, the vertical oscillator-output stage is loading the power supply, often the boost-voltage supply, so heavily that we get a momentary drop in voltage on every sync pulse—sort of an inverted surge. The drop in voltage supply to the horizontal oscillator causes a drop in frequency, and the top lines arrive late.

Two, some portion of the vertical

sync pulse is getting into the horizontal oscillator, phase comparator, etc.

To test for this, turn the set's brightness down, and disable the vertical oscillator. With the scope still connected to the horizontal output tube grid, switch in external sync. You can tell if the pulling disappears, because the thickening of the lines will go away.

Try checking the B-plus supply lines with a low-capacitance probe for any sign of vertical spikes or even sine-wave ac at 60 cycles. One rather unusual cause is cross-coupling in the yoke. However, most of these troubles are caused by bad electrolytic capacitors. Bridge each one, and, if they are parts of a multiple-section unit, disconnect each one and bridge one at a time. Leakage between units of multiple electrolytics is one very puzzling defect, so don't overlook it.

## Convert to 27-inch screen

*My customer wants to convert a Zenith 22L20 from its present 24CP4A CRT to a 27EP4. Can we do it?—G. P.,—West Chester, Pa.*

You should be able to. The 27EP4 actually calls for 2 kv less than the 24-inch tube. Same deflection angle, and the 27EP4 bulb diameter is really only 2-13/16 inches larger than the 24-inch. You'll probably have to add a 50- $\mu$ f 20-kv high-voltage filter capacitor, since the 27EP4 does not have an external conductive coating. With the reserve capacity in your sweep system, you should be able to sweep the extra inches without too much trouble. Set your horizontal linearity up for best linearity and minimum plate current and check the width setting. Also be sure you warn your customer of the cost of replacement CRT's.

## Transformer puzzle

*I have a vertical output transformer with the number 79B43-4. My distributor says that the number on this transformer has been changed to 79B391. When I tried it in the TV set, I get less sweep with the new transformer. The original transformer was a 79B29-1, and has three leads. I'm lost!—A. G.,—Union City, N.J.*

You forgot to give me the make of TV set but those numbers are unmistakable—it's an Admiral. Somebody

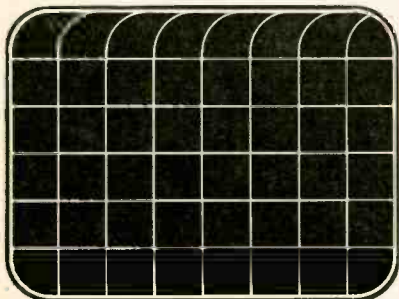

Fig. 1—Crosshatch pattern on TV screen reveals vertical pulling at the top of the picture.

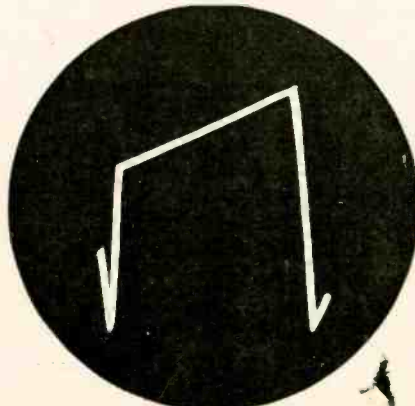

Fig. 2—Correct waveform on the grid of the horizontal output tube.

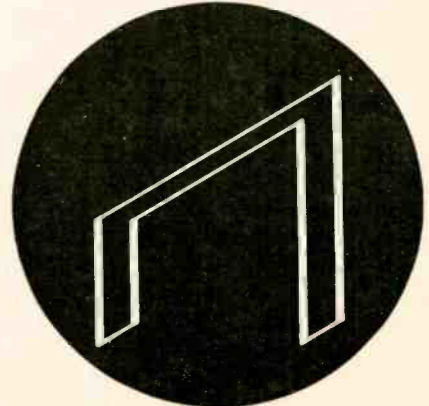

Fig. 3—Displacement of pattern caused by delay results in thickened vertical lines.

**"Now Pitching for New York, No. 33..."**

*"The Savoy Lounge proudly presents..."*



"My sermon for this morning deals with..."

**"WILL THE OWNER OF CAR 7Z-463 PLEASE..."**

*"FLIGHT 702 NOW LOADING AT GATE..."*

**"10...9...8...7...6..."**

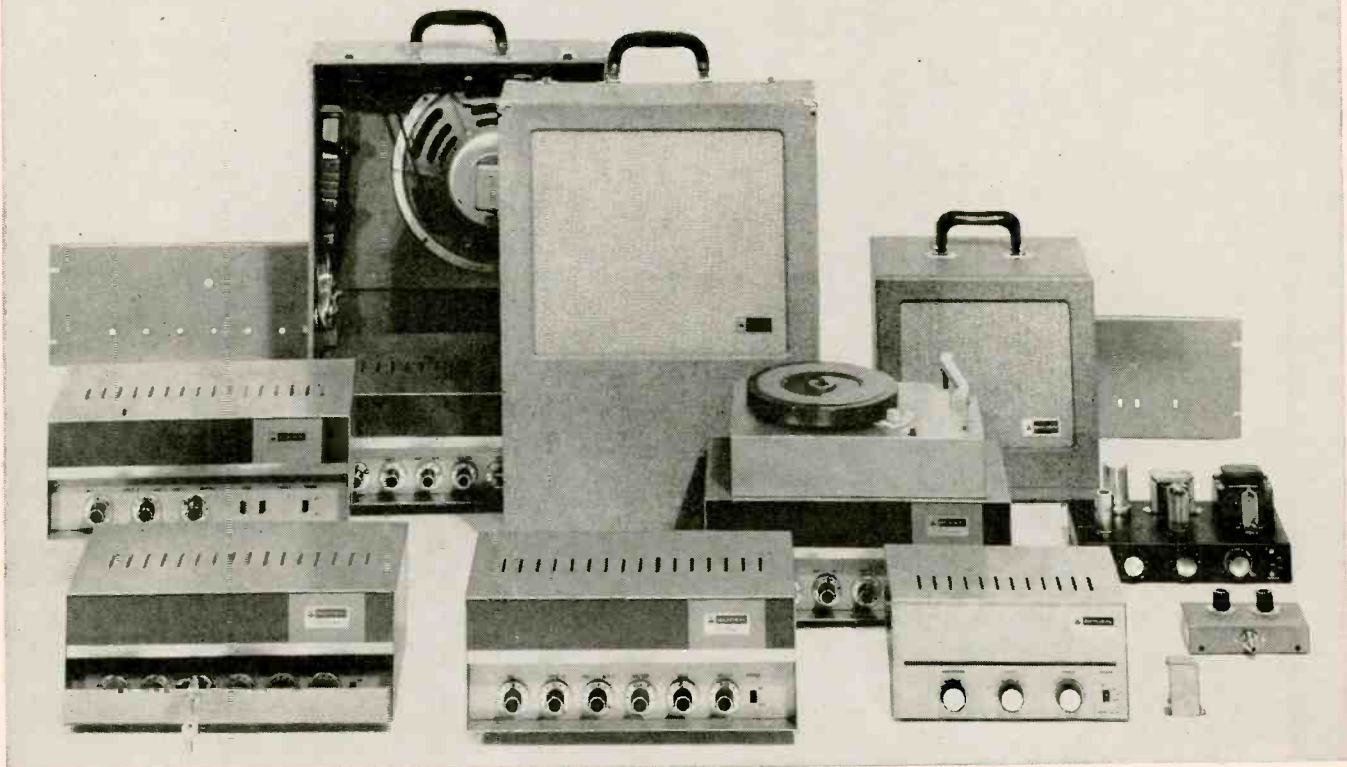

## the Sounds of the Sixties Sound Best thru New Bogen Challenger "CHB" P.A. Systems

**Versatility.** Whether you need P.A. to function above a stadium roar... or in the neighborhood recreation hall, there's a new CHB to fit your need. Ranging in power from 10 to 100 watts, CHB amplifiers are adaptable for indoor, outdoor, portable or mobile use. **Features and Accessories:** 4-speed phono, fastens to amplifier top • tamper-proof, front locking plate • continuous-duty circuitry • remote controller • circuit protection against accidental speaker-line shorting... and many more, previously featured in the exclusive BOGEN Flex-Pak line. **Reliability.** BOGEN's 30-year leadership in sound craftsmanship is your extra guarantee of rugged, dependable performance with minimum maintenance. In business, industry or government... most P.A. is by BOGEN—pioneer of the most significant developments in P.A. Write for CHB Catalog #311.

**BOGEN-PRESTO**   
DeskER-6, Paramus, N.J.—A Division of The Siegler Corporation

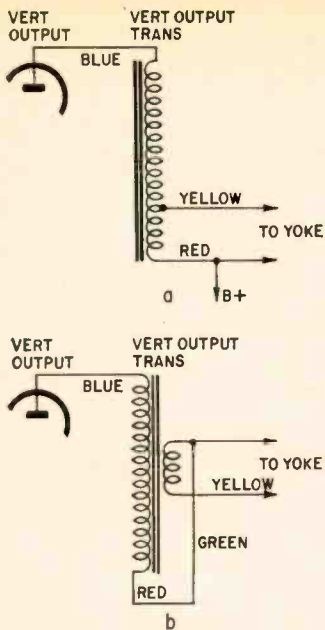

Fig. 4-a—Color coding of Admiral vertical output autotransformers. b—Standard transformer hooked up as autotransformer must have secondary winding in right phase. If picture is very small, reverse secondary connections.

else is mixed up, too. The 79B43-4 is a 15-to-1 autotransformer. The 79B39-1 is an 11-to-1 autotransformer, so you probably wouldn't get enough sweep, because of the impedance mismatch.

Standard color code on these transformers is blue for plate, red for B-plus and yellow for the yoke lead. The other yoke lead connects to B-plus (Fig. 4). In many cases, you can also use a dual-winding or standard transformer to replace an autotransformer by connecting the windings in the right phase. If you get the secondary reversed, you'll have a picture about 2 to 3 inches high.

#### Intermittent headache

*An RC 21T208 will run for about 2 hours, then pull in at the sides of the raster, start rolling vertically and black out. Turn it off for 5 minutes, and it'll go for another 2 hours. This is while the chassis is in the cabinet. Take it out and it'll run indefinitely!*—C. S. C., Cannel City, Kentucky.

This is obviously a thermal intermittent. The only difference between operation inside the cabinet and outside is the operating temperature. Therefore, take it out of the cabinet, and apply heat selectively. A standard heat lamp in a gooseneck desk lamp is a good source for the first test. Use a mask to confine the heat to a circle about an inch in diameter. Direct this on the vertical oscillator or output transformer first. From your description, I suspect some trouble there, such as intermittently shorted turns in the vertical output transformer. This stage is fed from the boost voltage, and any overload here would load down the boost, causing the shrinkage and probably the vertical rolling.

There are other suspects too. Check

the width and linearity coils by heating them up. Look to see if they are darkened or charred. They may have an intermittent short to the cores. The flyback is another good suspect. A drop in the boost voltage caused by flyback or high-voltage supply troubles could cause the rolling by changing the plate voltage on the vertical oscillator and output stages.

For a pinpoint check, apply heat with the tip of a soldering iron to all suspected parts in all these circuits. Also, check the damper-tube socket for an intermittent leakage.

#### Slow warmup

*The complaint is that a Dumont RA-165 is becoming progressively slower about producing a raster. Can you give me some advice about this?*—W. R. J., Toronto, Ont., Canada

The most frequent cause is a slow-heating picture tube. However, if the tube produces a good picture after it finally does get hot, it isn't too serious. The best thing to do is check the picture tube with a good tester; this will tell you whether the tube is weak. If it is, many times a "rejuvenation" will help in making it heat faster.

The tester will tell you whether using a brightener will help. We don't recommend installing brighteners until the tube's output has fallen so low that it is necessary to overheat the cathode to get enough beam current. Using brighteners on a normal tube will shorten its life of course.

Another possibility, of course, is a slow-heating horizontal output or (more likely) damper tube. You can check this by measuring the high voltage during warmup. If it comes up to its normal value quite a while before the screen shows a raster, then the CRT is slow. If the voltage comes up slowly, check the horizontal output and high-voltage sections.

Incidentally, time the actual warmup with a watch—never estimate. If the tube shows light within 1.5 minutes, it's nearly OK. Most people grossly overestimate the time!

#### Tuner trouble

*I have a Philco 22D4330 in the shop. Channel 10 comes in on channel 9. What is my trouble and how can I remedy it?*—F. B. Newark, Ohio.

This is caused by a misalignment or, more correctly, miscalibration of the tuner oscillator. This set uses an incremental inductance tuner. This means that there are basically only two oscillator coils used—one for the high channels and one for the lows. The switch in the tuner shorts out sections of the inductor until it is resonant on the desired channel.

Proper tuning procedure on these tuners is always to begin at the highest frequency channel, and tune the small brass screw visible through a hole in the front for best picture and sound. There will be one screw for each channel, usually numbered. Then tune the next lowest, and so on. If your channel 10 is the highest channel avail-

able locally, tune it first, then check the rest, tuning if required. If it is way off, move the channel 13 slug a quarter-turn, then go back to channel 10. You will find a marked change. A quarter-turn on channel 13 may have as much effect as five full turns on channel 10.

#### Horizontal instability

*This chassis has been pushing me around quite a bit. It will start in sync, run for about 5 minutes, then fall out. Tickle the horizontal oscillator transformer, and it runs from then on. I took all the old tubes out, put them in a bucket and started with a fresh batch off the shelf. This didn't do it, so I took those out, and put in another batch.*

*All voltages, waveforms and everything else are absolutely normal. Resistors and capacitors all check OK.*—R. C. S. Troy, N. Y.

I'm sorry to say that it looks as if you are blessed with a good thermal intermittent! From the time constant of the defect, I don't think it will be a tube; this sounds more like a heat-sensitive capacitor or possibly a resistor. When the trouble appears, try heating each capacitor and resistor in the frequency-controlling circuits: the shapers, coupling capacitors, capacitors across the ringing coil, etc. It will undoubtedly take you some time, but that is where it will be found.

A can of the "cooling compound" recently marketed is a great help in cases like this. It is a standard spray can like those used for cleaners, but it contains only the propellant. When sprayed on a suspected part, it cools it very rapidly, and the resultant temperature change will often dig out a stubborn intermittent. If any part seems to be heat-sensitive, try touching each part with the tip of a soldering iron, just long enough to raise its temperature above normal.

#### Replacement transformer

*I need a power transformer for a Tech-Master C-30 TV, but am unable to locate the parts here. Can you help me find a suitable replacement?*—G. S. H., Ontario, Canada.

A Triad R-61-BC will replace the power transformer in this set. This transformer has three 6.3-volt filament windings, two at 6 amperes, and a separate winding for the damper heater. To use this unit in the Tech-Master set, connect the two 6-amp windings in series, phasing them properly to give you the 12 volts needed (Fig. 5). END

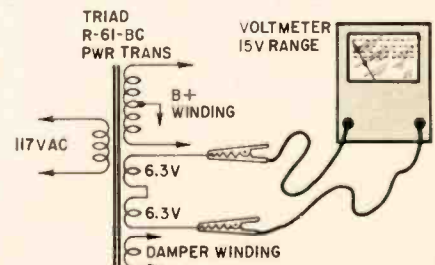

Fig. 5—Connect the two 6.3-volt windings in series adding to get the 12-volt winding needed in a Tech-Master C-30. The voltmeter shows when they are connected properly.

# LAFAYETTE

## AMERICA'S VALUE LEADER

### HI-FI · AMATEUR · CB · RADIO

#### NEW! LAFAYETTE STEREO FM MULTIPLEX ADAPTER KIT

**19<sup>50</sup>**

- Stereo Separation—30db @ 400 cps
- Less Than 1% Distortion
- Self-Powered
- Noise Filter (switchable)
- Prealigned Coils
- 3 Tubes—2 Dual, 1 Triple-Purpose Tube + Silicon Rectifier



Enjoy thrilling FM Stereophonic sound from any recent Lafayette Tuner or any other quality wide-band FM or FM-AM tuner with multiplex jacks. Hear the full range of audio frequencies in all the realism and magnificence of stereo sound by simply adding this low-cost Lafayette Multiplex adaptor kit. Engineered for anyone to build and operate, the KT-220 is easily connected to your tuner.

The KT-220 Multiplex adaptor is supplied complete with shielded cable for input and output connections; metal case and all parts plus the famous Lafayette detailed kit instruction manual. Front panel is finished in beige and ivory trim with contrasting beige and brown cabinet. Size 8½Wx4¾Dx 4¾" H. For 110-125 volts, 60 cycle AC. Shpg. wt., 4 lbs.

KT-220

Net 19.50

#### NEW! LAFAYETTE HE-20B CLASS D Deluxe CITIZENS BAND TRANSCEIVER



**109<sup>50</sup>**

NO MONEY DOWN

NOW WITH These ADDED FEATURES

- 8 Crystal — Control Receive Positions
- 8 Crystal — Control Transmit Positions
- Built-in 12 Volt Power Supply
- Efficient Pi-Network
- Improved Series Gate — Noise Limiter
- 14 Tube Performance — 3 Diodes
- Complete with crystals for Channel 9

Quality engineering, design, and features give this Deluxe transceiver a place all-its-own in the Citizens Band Field. Operating within the limits prescribed by the FCC, the HE-20B supplies you with a highly efficient 2-way radio-telephone communications system from your office, truck, auto, boat, store, home, etc. Size 12x5x8½". Shpg. wt., 14 lbs.

HE-20B

109.50

#### FAMOUS "MIGHTY 9" T.M. 9 TRANSISTOR PERSONAL PORTABLE

**19<sup>95</sup>**



- 9 Transistors, 2 Diodes, 1 Thermistor
- Lightweight, Shirt Pocket Size
- 4 Audio Stages
- Full Tone Speaker
- Complete with Leather Carrying Case, Batteries and Earphone

Lafayette's "Mighty-9" portable, the most powerful transistor radio, is the answer for those who want the best, without spending the most. Compare this portable with others selling for much more — compare feature for feature and you'll see why the Lafayette "Mighty-9" is your best buy. Size: 4½Hx3Wx1¼"D. Shpg wt., 2 lbs.

FS-91L

19.95

#### LOW COST 4-BAND SHORTWAVE BROADCAST RECEIVER In A Smartly Styled Durable Metal Cabinet



**49<sup>95</sup>**

NO MONEY DOWN

- Built-in "S" Meter
- AVC — Noiselimiter
- Electrical Bandspread
- 3 Short-Wave Bands, 1 BC Band
- Big 5 Inch Speaker
- BFO
- Phone Jack

Now, you can tune in the world with this fabulous, new Lafayette HE-40 BC-SW receiver, keep up to date with on the spots news coverage. Power packed superheterodyne circuit covers the broadcast band (550-1600KC) and shortwave from 1600 KC to 30 MC in four bands. The perfect radio for shortwave listeners. Features a precision electrical bandspread with slide rule band-spread dial; separate bandspread tuning condenser and calibrated "S" meter for accurate tuning. Powered by 4 tubes plus a selenium rectifier. Operates on 105-125V; 50/60 cycle AC/DC. Size 13½Wx 5¾Hx8¾"D. Shpg. wt., 12 lbs.

HE-40

Net 49.95

#### NEW! LAFAYETTE 4 TRANSISTOR PUSH-BUTTON TAPE RECORDER

No Money Down

**29<sup>95</sup>**

Complete with Microphone, Earphone 3" Reel of Tape, Empty Reel, Batteries

FOR HOME, SCHOOL, OFFICE

- Lightweight — A mere 2¼ lbs.
- Records and Plays Up to 20 Minutes With 1 Standard 3" Reel
- Pushbutton "Play," "Rewind," "Off"
- Battery Operated
- Completely Portable — Take it With You Anywhere

A real triumph in miniature recorders. Space age printed circuitry using a 4 transistor push-pull amplifier and built-in oval 2½x4" PM Speaker provides quality sound. Has all the most wanted features: convenient push-button Fast Rewind, Off and Play controls. Record safety interlock prevents accidental erasure of tape. Volume control is independent of "Off" Switch. Erases automatically in record position. In handsome two-tone plastic case. Dimensions: 8Wx3½Hx7¾"D. Shpg. wt., 4 lbs.

RK-133L

Net 29.95

## LAFAYETTE'S

NEW MAIL ORDER HEADQUARTERS  
111 JERICHO TURNPIKE  
(2 Blocks West of South Oyster Bay Rd.)

SYOSSET  
LONG ISLAND, NEW YORK



LAFAYETTE RADIO DEPT. JF-2  
P.O. BOX 10, SYOSSET, L. I., N. Y.

- Rush my FREE Lafayette Summer Catalog Supplement
  - Please send me # \_\_\_\_\_, Shipping Charges Collect
- I am enclosing \$ \_\_\_\_\_.

Name \_\_\_\_\_

Address \_\_\_\_\_

City \_\_\_\_\_ Zone \_\_\_\_\_ State \_\_\_\_\_

**FREE!**



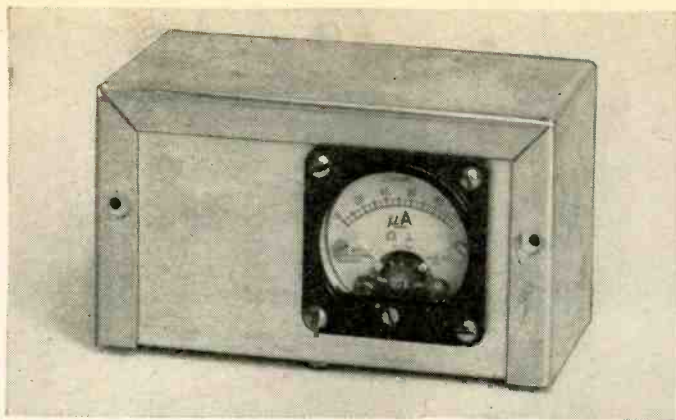

# expanded-scale voltmeter

0.4 volt makes the difference between zero and a full-scale reading

By I. QUEEN  
EDITORIAL ASSOCIATE

THIS METER CAN MEASURE SMALL DIFFERENCES in voltage. It ranges from about 0.9 to 1.2 volts dc. The tables with the circuit show typical calibrations.

The applied voltage lights a 6.3-volt pilot lamp. At the low voltage the light is very dim, but is enough to affect a cadmium sulphide photocell. This cell acts like a variable resistor, its output depending upon the light received and on the energizing voltage which is the dc being measured.

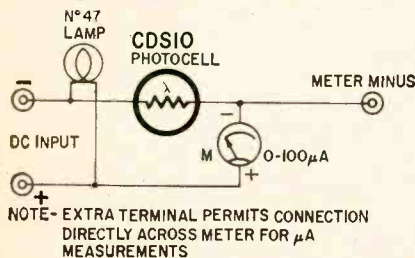

μA READING	INPUT VOLTS (dc)	μA READING	INPUT MA (dc)
10	.9	10	55
20	1.0	20	60
35	1.1	60	65
62	1.2	100	68
100	1.3		

Circuit of the simple unit along with typical calibration charts.

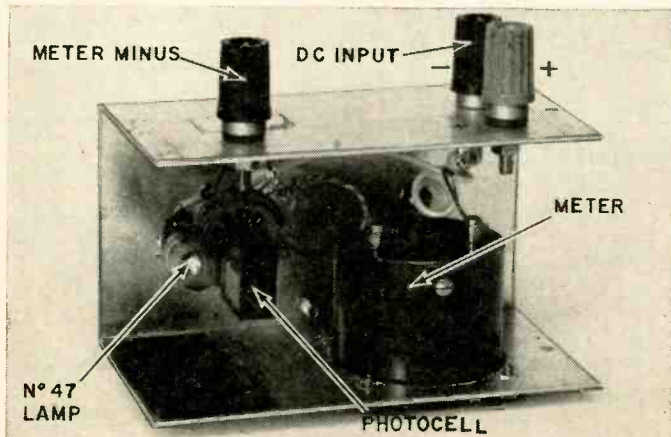

Interior of the expanded-scale meter.

The cell must be shielded from external illumination during measurement. All parts are housed inside a 4 x 2 3/4 x 2 3/4-inch metal box. The meter is 1 1/2 inches square.

Parts placement is not critical, except that the lamp must be quite close to the cell—about 1/2 inch away. For convenient mounting, clip the long leads of the cadmium sulphide cell and plug them into a nine-pin miniature socket. Also, with the aid of heavy wires, solder the lamp to convenient pins on the same socket. Thus the lamp-cell combination becomes a single, fixed unit that can be mounted inside the box. I found results improved when a metal-foil hood was placed over the assembly. It reflects more light from the lamp onto the cell.

This meter is useful for checking the condition of a rechargeable nickel-cadmium cell. These vary only a few tenths of a volt from full charge to discharge, making a conventional meter useless. With the expanded meter, the deflection is about one-third full scale for a difference of only 0.1 volt. Note, also, that the source being measured is loaded to some extent by the lamp, a desirable condition. For this reason, use reasonably heavy leads to measure the battery. A high resistance in the circuit will lower the true reading. END

# What's Your EQ? May Solutions

## Variable-Current Black Box

The circuit is as shown. To solve, first calculate the dc, which must be passing through a resistor of 25 ohms. Since the voltage-current product at

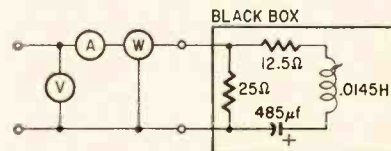

60 cycles equals the power, a series-resonant circuit is suggested. The current at 400 cycles permits the reactance to be calculated. Then the inductance, capacitance and resistance in the ac circuit can be found.

## An Easy One

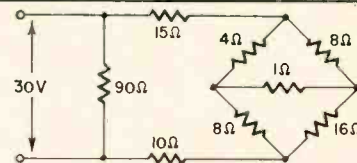

If we lay out the resistors in the pattern shown in the sketch, it becomes an obvious balanced bridge. So the drop across the 1-ohm resistor is zero.

## Iterative Network

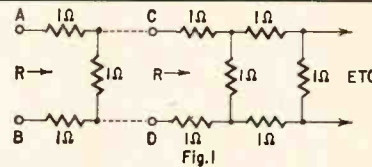

We can make this circuit (Fig. 1) more easily understandable by breaking it just after the first section and labeling the new inputs C and D. Since the lattice extends to infinity, we also see resistance R at points C and D. Now we can draw an equivalent circuit as in Fig. 2. This is a simple series-parallel combination which we can solve.

$$R = 1 + 1 + \frac{R}{R + 1}$$

The last term is the parallel combination of R and 1 ohm. Multiplying both sides of the equation (by R + 1 to get rid of the fraction, we get:

$$R \times (R + 1) = 2R + R + 2,$$

which is equivalent to:

$$R^2 - 2R - 2 = 0.$$

This works out to:

$R = 1 \pm (3)^{1/2} = 2.735$  ohms. The negative solution is an entirely different story, and not applicable to our present problem.



# FREE!

## WORLD'S BIGGEST KIT CATALOG!

**SEND FOR YOUR COPY TODAY!**

You'll find hundreds of low-cost, easy-to-build Heathkit products in this value-filled catalog . . . the world's largest and most complete! Over 250 different Money Saving kits are shown with complete descriptions, schematics, big photographs and full specifications. Send for your copy today! Save up to 50% of the cost of comparable products by doing the easy assembly yourself! All kits are fully guaranteed and available on no money down terms! Use the handy coupon below.

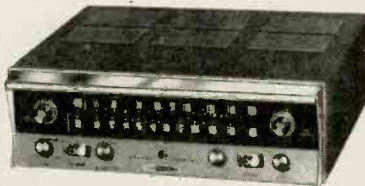

**DELUXE FM STEREO TUNER:** Brilliantly engineered. AM, FM and built-in FM Stereo Multiplex. Indicator light signals when FM stereo is being broadcast! Adjustable AFC and FM squelch; tuning meters, circuit boards.  
**Kit AJ-41**...no money down \$11 mo. **\$119.95**  
**Assembled AJW-41**, \$18 mo. .... **\$189.95**



**CB TRANSCEIVER:** Low-cost, two-way radio! Crystal controlled superhet receiver and transmitter; squelch and automatic noise limiter; Push-to-Talk microphone; built-in AC power supply; provision for plug-in DC supply.  
**Kit GW-12A (AC only)** 8 lbs. \$5 mo. **\$39.95**  
**Kit GW-12D (AC & DC)** 11 lbs \$5 mo. **\$44.95**



**MARINE RADIO TELEPHONE:** Factory wired and tested! 50-watt transmitter. 5 crystal-controlled transmit and receive channels. Covers 2-3 mc marine and standard broadcast bands. Built in vibrator power supply. An outstanding value! 25 lbs.  
**Assembled MWW-11A**, no money down, \$24 mo. .... **\$259.95**



**TUBE CHECKER KIT:** Latest design. Tests all tubes including Compactron, Nu-vistor, Novar and 10-pin miniaturess! Built-in roll chart. Individual tube element switches. Perfect for service. 11 lbs.  
**Kit IT-21**...no money down, \$5 mo. **\$44.95**



**SSB MOBILE AMATEUR TRANSMITTER:** 90 watt input, 80 through 10 meters, crystal bandpass filter, dual conversion heterodyne circuitry, automatic level control, switch selection of USB, LSB and CW, VOX or PTT operation. 19 lbs.  
**Kit HX-20**, No money down, \$19 mo. **\$199.95**

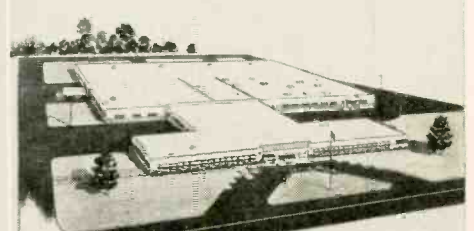

World's oldest and largest manufacturer of do-it-yourself electronic kits



**HEATH COMPANY**  
 BENTON HARBOR, MICHIGAN

All prices and specifications subject to change without notice.  
 JUNE, 1962

**HEATH COMPANY**  
 Benton Harbor 20, Michigan

Please send my free copy of the 100 page 1962 Heathkit Catalog

Name \_\_\_\_\_

Address \_\_\_\_\_

City \_\_\_\_\_ Zone \_\_\_\_\_ State \_\_\_\_\_

# RATAN- Harbor TV-Radar

*Any uhf TV set becomes  
a radar indicator with  
this new system*

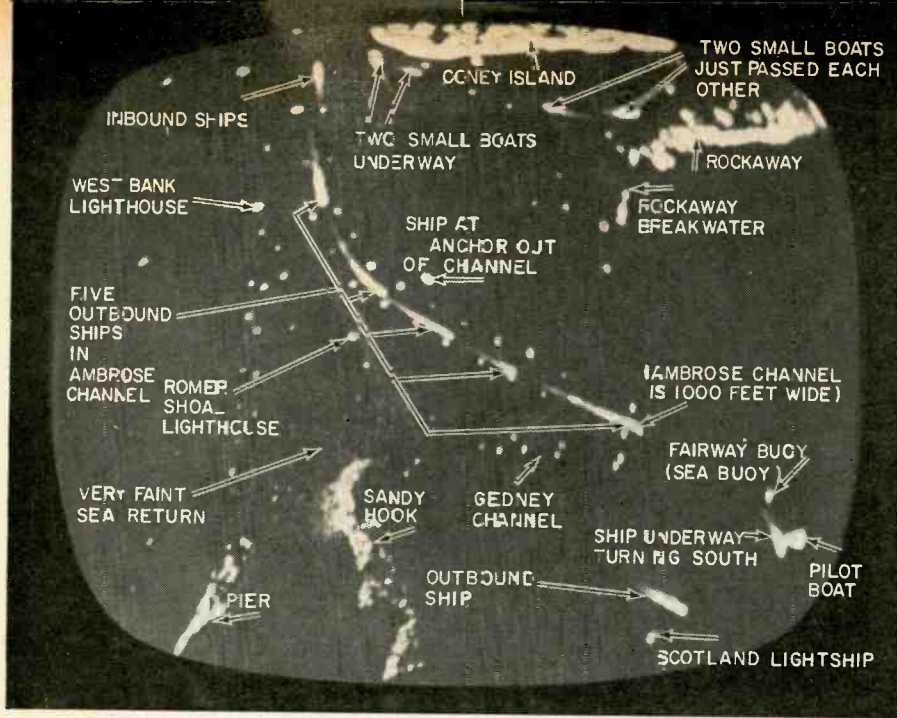

Area just outside New York Harbor, as seen on RATAN screen.

A NEW TYPE OF RADAR PRESENTATION may give the small boatman all the benefits of marine radar for the price of a portable TV receiver. Demonstrated recently by the Coast Guard to the technical press, the new system is called RATAN (*Radar and Television Aid to Navigation*). The pressmen saw a scene on the TV screens like the one shown in the photo here. Their own ship, the US Coast Guard Cutter Spencer, could be followed on the TV screen throughout the voyage from New York Harbor to Sandy Hook, off the coast of New Jersey.

The new system differs in several respects from conventional PPI (*Plan Position Indicator*) radar. Most important—to small boatmen, at least—is that the radar scope is any uhf TV receiver. The second point is that RATAN shows each ship in position on a map of the area, unlike the PPI scope, which shows your own ship standing still in the center of the universe, with everything else moving in relation to it. The third fea-

ture is that moving vessels show a "wake", due to the persistence of the scope trace. This persistence is controllable by the transmitter operator. Because of the "wake", moving objects can be distinguished from stationary ones. The direction in which a vessel is moving is easily noted and, within limits, its speed can be determined. The long-persistence screen produces another effect. Buoys not easily seen on a PPI scope, continue to come up in brightness until they are easily recognizable on the longer-persistence RATAN.

### How it's done

The secret of the new radar is an instrument that Raytheon calls a "scan-conversion unit." Part of this is a specially developed scan-conversion tube, a double-ended device. One end is a picture storage tube, on which the radar presentation (or any other TV picture) can be held any desired time. The other end is a flying-spot camera tube, which

scans the picture on the storage face and presents the signals to a uhf TV transmitter.

The scene shown at the Coast Guard demonstration was picked up with an ordinary radar—a Raytheon 1605—at the Coast Guard station at Sandy Hook. The conversion unit picked these signals up as a conventional PPI presentation, and fed them out as a TV raster to a uhf TV transmitter, working on channel 47 (671 mc).

RATAN has one limitation. It is what in Europe is called a "harbor radar," covering a fixed area around a permanent radar station. Larger ships would, in addition to RATAN, carry their own radar.

To the small boatman, the advantages are overwhelming. It gives him radar where he needs it most, and at a price he can afford—that of a portable TV. Further, he can understand the RATAN display much more easily than he could a PPI scope. He might have trouble identifying his own craft, but this can be solved in a number of ways. Possibly the easiest is by making what aviators call a procedural turn, and watching for the trace on the screen.

In crowded harbors or heavy fog, such maneuvers would have their disadvantages. A "position locator", a rotating, highly directional beam, so gated on and off that it would be visible to a viewer only when the antenna pointed in his direction, has been proposed. The boatman would see a white line from the transmitter crossing his own craft. This solution was proposed in a paper read to the IRE Convention by A. Roberts of General Precision, and it—or some similar device—may eventually be incorporated into the system. **END**



How display looks to boatman. Small circle of wire behind set is antenna.

Scan-conversion tube that changes PPI display into TV image.



# select the Blonder-Tongue home TV booster that's best for you

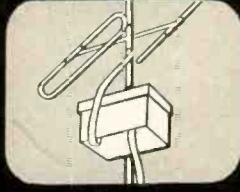
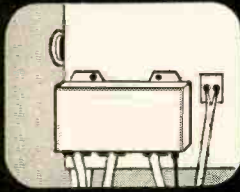

indoor or outdoor

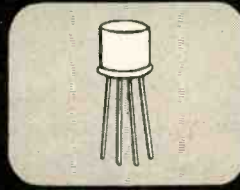
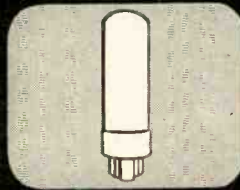

tubed or transistor

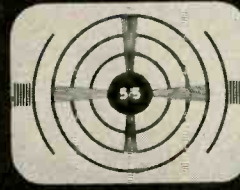
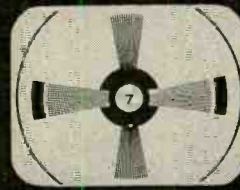

VHF or UHF

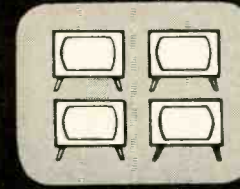
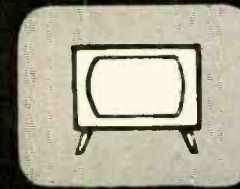

1 set or 4 sets

<sup>3</sup>Stripless terminals on all these Blonder-Tongue TV amplifiers assure positive electrical connection with the turn of a screw.

## new! IT-4 TRANSISTOR 4-SET TV/FM BOOSTER.



- excellent fringe area reception on 1 to 4 sets from a single antenna—low noise transistor circuit increases signal voltage from 3 to 8 times on a single set.
- A complete home TV system — improves reception on up to 4 TV or FM sets Exclusive built-in 4-set coupler.
- long term performance — long-life transistor means no heat dissipation problems, no tubes to burn out or replace.
- exclusive neutralizing circuit minimizes overload problems (in areas with strong local signals, however, use a tube powered booster such as the B-33 or B-24c).
- easy to install anywhere in the home. ....List \$33.00.

## new! B-33 LOW COST 3-SET TV/FM BOOSTER.



- excellent fringe area reception — frame-grid tube circuit provides high gain, low noise — more than doubles the signal voltage for a single set.
- sharp, clear pictures on up to 3 sets from a single antenna — when 3 sets are used, each set gets as much signal voltage as is picked up by the antenna. Excellent inter-set isolation — amplifies color signals.
- ideal where there are both strong and weak channels — a tubed amplifier minimizes the problem of overload.
- easy to install anywhere in the home. ....List \$19.95.

## 4 PERFORMANCE-PROVED VHF & UHF BOOSTERS

**MODEL AB-4-AC, Transistor Mast-Mounted TV/FM Booster w/remote AC power supply.** Provides brilliant reception on up to 4 TV or FM sets from a single antenna. Mast-mounting takes advantage of the optimum signal-to-noise ratio. ....List \$34.95.

**MODEL AB-4 with remote battery power supply.** ....List \$29.95.

**MODEL B-24c, 4-set TV/FM Booster.** Low cost home TV system uses rugged frame grid tube to provide signal power for as many as 4 TV or FM sets. ....List \$24.95.

**MODEL BTA, TV Booster.** Lowest cost booster on the market. Improves TV reception in prime or weak signal areas. ....List \$15.70.

**MODEL UB, UHF Booster.** Brings in UHF where all other methods fail. 5 models cover all channels from 14 to 83. ....List \$88.00.



For better TV reception — anywhere — see your Blonder-Tongue service-dealer. Write for literature.

engineered and manufactured by

# BLONDER-TONGUE

9 Alling St., Newark, N. J.

Canadian Div: Benco Television Assoc., Ltd., Tor., Ont. Export: Rocke Int'l. Corp., N. Y. 16—CABLES: ARLAB  
home TV accessories • closed circuit TV systems • UHF converters • master TV systems

**BUILD THE FINEST**  
*Professional Quality*  
 CUSTOMIZED  
**TV KIT**

On Easy "Pay As You Wire" Terms  
 Only \$15 for the Starting Package!

The  
**"PROFESSIONAL"**  
 Series—designed for  
 the perfectionist seeking  
 the finest in TV performance.  
 Easy to assemble. No technical  
 knowledge required. An ideal  
 "Learning" Kit with a Complete  
 Course of Study is available.

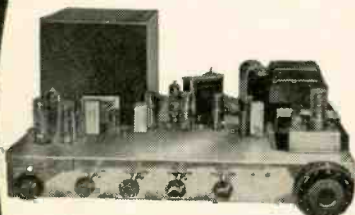

Also available:  
**WIRED  
 CHASSIS**  
 for custom  
 installations  
 with a choice  
 of vertical or horizontal  
 controls and the newest  
 19", 23" or 27"  
 Picture Tube.



*Beautiful Cabinets* —  
 designed to enhance sound quality and blend with  
 modern decor. For TV or combination TV and Hi-Fi.

**A few of the Professional Quality Features:**

Choice of push-pull 10-watt audio or output to  
 your Hi-Fi system . . . D.C. Restoration . . .  
 Ultra-linear sweep circuits . . . Newest Stand-  
 ard Coil Model PKO Automatic Fine Tuner . . .  
 Super-sensitivity for fringe areas . . . Complete  
 line of Accessories for Custom Installations.

**CHOICE OF 19", 23" or 27" CRT.** Prices  
 range from \$119 to \$199.

U.S. Armed Services and over 4000 schools and  
 colleges have selected Transvision Receivers for  
 educational television.

*Interested in Electronics?*

Learn the basic principles of elec-  
 tronics from the Course available with the Kit.

**ASSEMBLY MANUAL—\$2.00**

See how easy it is to assemble the Transvision  
 Kit. Cost of Manual refunded on purchase of Kit.



Grey Oaks Ave.  
 Yonkers, N. Y.  
 YO 5-6900

**START NOW — MAIL THIS COUPON —**  
 TRANSVISION ELECTRONICS, Grey Oaks Ave.,  
 Yonkers, N. Y., Dept. RE-T6.  
 Send FREE 8-page Catalog...  I enclose \$2 for Assembly  
 Manual, refundable on purchase of Kit.  
 I enclose \$15 for Starting Pkg. on pay-as-you-wire plan.  
 (Complete Kits range from \$119 to \$199.)

Name \_\_\_\_\_  
 Address \_\_\_\_\_  
 City \_\_\_\_\_ Zone \_\_\_\_\_ State \_\_\_\_\_

**EQUIPMENT REPORT**

# 2 New Tools for Transistor Servicing

*Heathkit IM-30 transistor checker and B & K model 960 tran-  
 sistor radio analyst*

By **WAYNE LEMONS**

A new self-powered transistor tester with features usually found only in more expensive testers, has been recently introduced by Heathkit. The model IM-30 checks dc beta and dc alpha, using a special bridge circuit. Bridge null is indicated on a zero-center, 10-0-10 microammeter. Lever switches set the different functions. The instrument checks for  $I_{CBO}$  and  $I_{EBO}$  leakage, collector-to-emitter shorts, dc gain and by calculation, ac current gain and ac and dc transconductance, base resistance and collector resistance. Diodes can be checked for forward and reverse current.

Other switches select collector voltage, leak voltage, leak current ranges, collector current ranges and

the correct polarity for p-n-p or n-p-n transistors.

A bias control across an internal 1.5-volt battery adjusts collector current to any desired value between 0 and 15 amps. The dc beta (gain in common-emitter circuit) control is calibrated in two ranges: 0-150 and 150-300. The dc alpha is also calibrated on this control in two ranges from 0-0.9966. High- and low-gain ranges are selected by a front-panel switch.

The IM-30 has external binding posts for using external batteries or power supplies for making gains and leakage tests at higher voltages than the internal 9-volt battery supply. Meter scales and ranges are included in the instrument to measure these external sources up to 50 volts. External



**The Heathkit IM-30 transistor checker on the job.**



**NEW LOW PRICES—ONLY CHANGE WE COULD THINK OF**

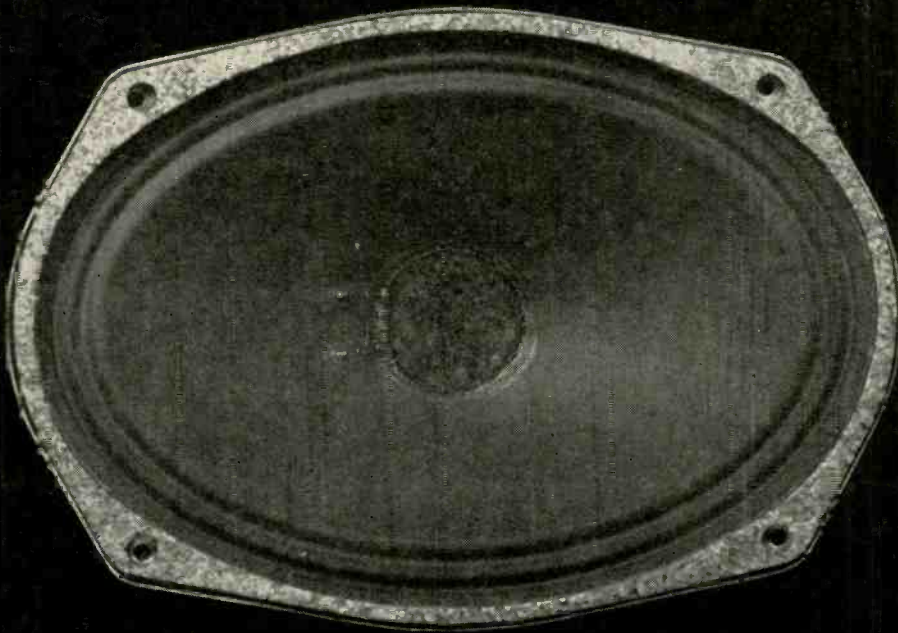

**TO MAKE THESE SPEAKERS SOUND BETTER THAN EVER!**

# simply say **Delco**

You've *always* been able to install Delco Auto Radio Speakers with complete confidence in their quality. Now you can sell this popular line at competitive prices as well!

And Delco hasn't sacrificed a single one of these outstanding features: Highest sensitivity for greater range of distortion-free sound from precision-engineered magnetic circuits • Extra-efficient, premium grade Alnico-V magnets • Continuous life testing program to assure dependable

performance under the most severe climatic conditions.

There's news in Delco *packaging*, too. Your choice 6 x 9's in new bulk-packs, 20 speakers to a carton, or individually boxed speakers if you like. Now that you can sell top quality Delco Auto Radio Speakers at new, competitive prices, better stock up and start cashing in! Call your supplier and—simply say Delco. **Delco Radio** Service Parts are distributed nationally through **United Delco**.

DELCO RADIO, Division of General Motors, Kokomo, Indiana

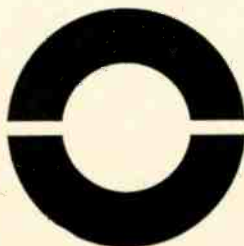

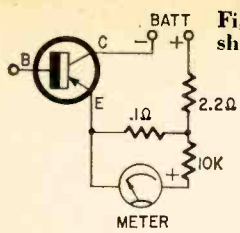

Fig. 1—IM-30 short test.

Fig. 2— $I_{CEO}$  leakage test, similar to short test except that meter ranges are much more sensitive.

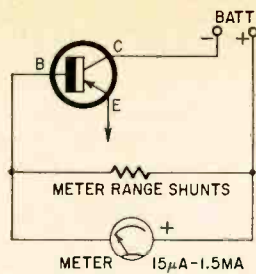
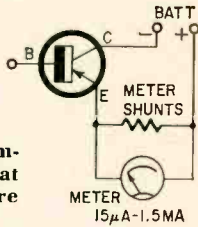

Fig. 3— $I_{CBO}$  leakage test. Collector-to-base with emitter open.

currents can be read in ranges of times 10 from 15  $\mu$ a to 1.5 ma.

### Using the IM-30

The IM-30 can be used in service shops to check all transistors including small signal, power, and special types (both p-n-p and n-p-n) for shorts, leakage, gain and other special tests if desired, as well as for checking diodes. Transistors are checked under actual dc operating conditions with voltages similar to those found in the transistorized equipment. The IM-30 is ideal for matching transistors. It is especially good for go-no-go production-line testing. You can set the unit for specified test conditions, check each transistor for shorts, and to see if leakage is within allowable limits.

To check gain, set up the desired bias conditions and set the gain test control for the minimum allowable gain. Pull the gain lever. The transistor under test will deflect the meter one way if the gain is low, the other way if the gain is higher. (Direction of meter indication is determined by whether the transistor is a p-n-p or n-p-n type.)

This looks like a good tester for service technicians, production-line testing, design engineers or just about anyone working with transistors. Fairly easy to assemble, it should take the casual kit builder no more than 8 hours. Just be careful to keep solder from running into the switch rotors. Solder with the terminals *down* so any stray solder will run out of rather than into the switch mechanism.

### B&K model 960

A new instrument that goes a long way toward solving the extra equipment problem for transistor radio service is the new B & K. They call it a Transistor Radio Analyst. It features a 0-12-volt power supply, tapped in 1.5-volt steps, and a single probe "in-circuit" transistor and stage tester. In addition, the model 960 provides a 2-band signal generator (250 to 2,200 kc), a 2,000-cycle audio generator, a vacuum-tube volt-ohmmeter; and an out-of-circuit transistor tester.

Fig. 7 is a simplified circuit of the rf-af signal generator. Half of a 12AU7 uses separately switched-in oscillator coils to cover 250 to 800 kc (band A) and 800 to 2,200 kc (band B). An RF OFF switch disables this circuit when it is not needed.

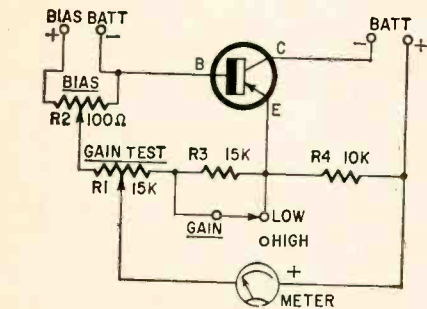

Fig. 4—Bridge gain test circuit. R3 extends beta range to 300 when switch is in the high position.

bias voltage terminals are also provided.

For transistor radios, the supply in the IM-30 is adequate. For video output and sometimes other transistors in transistor TV's, and for special-purpose and industrial transistors, a higher test voltage may be desirable. Occasionally, a transistor will check OK on a low-voltage test, but have excessive leakage at its rated or operating voltage. This is true even in transistor radios. The IM-30 lets you select the leakage voltage you want to use (which should always be approximately the operating voltage of the transistor in the set) in 1.5-volt steps up to 9 volts. Collector voltages for gain tests can also be selected in the same manner.

### Breakdown of tester circuits

Fig. 1 is a simplified circuit of the IM-30 SHORT test. This is made between collector and emitter with the base open. A low-resistance shunt across the meter, and a 10,000-ohm resistor in series with it, protect the meter from damage if the transistor is shorted.

Fig. 2 shows the  $I_{CEO}$  LEAKAGE test and is identical to the short test except that the meter shunt is selected by a front-panel switch to give a much more sensitive meter indication (15  $\mu$ a to 1.5 ma). An  $I_{CBO}$  LEAKAGE test measures leakage current from collector to base with the emitter open (Fig. 3).

Fig. 4 shows the GAIN measuring bridge circuit. In this test, the meter shows the difference between the voltage drop across R4 (10,000 ohms) and GAIN TEST control R1 (15,000 ohms). The gain control is adjusted until the voltage drops are the same—this is indicated by a zero (center) reading

on the meter. The farther the control must be turned toward the base, the greater the gain of the transistor. For gains above 150, resistor R3 (15,000 ohms) is switched in to extend the range from 150 to 300. The gain control is also calibrated in dc alpha. Alpha is beta divided by beta plus 1.

When beginning a transistor check, set the dc bias control until the

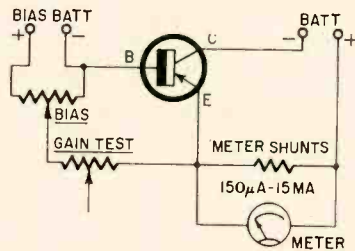

Fig. 5—Collector current is adjusted by bias control. Meter current ranges in multiples of 10 from 150  $\mu$ a to 15 ma.

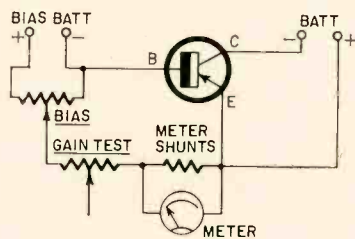

Fig. 6—Base current from 15  $\mu$ a to 1.5 ma can be read by this circuit.

collector current reads the desired value, usually about 5 ma for small-signal transistors. (Bias may be set so the collector current is most any reasonable value. It will have no effect on the gain reading.) Fig. 5 shows this collector-current test circuit. Fig. 6 is the simplified base-current circuit. Base

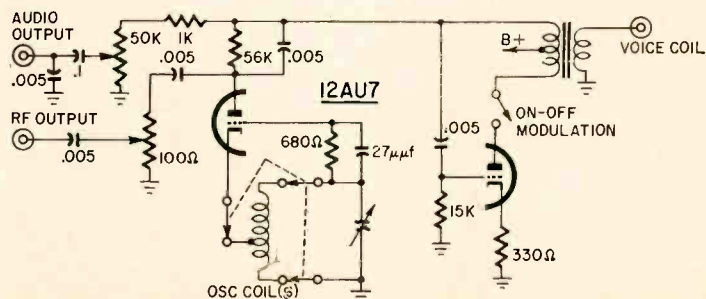
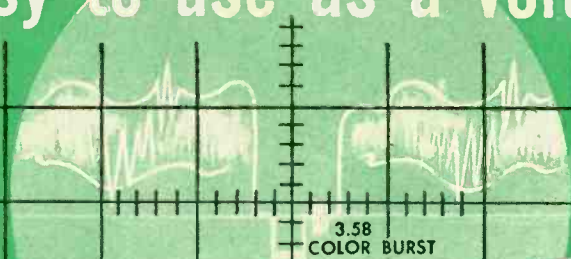

Fig. 7—Simplified circuit of rf-af generator in the B & K 960.

NEW, MODERN, PORTABLE... FOR THE MAN ON THE GO...

as easy to use as a voltmeter



- A new 3 inch Extended View Portable Scope with New Features and Performance Unmatched by even the most Costly 5 inch Oscilloscopes



Only 124<sup>50</sup> net

**NEW**

## SENCORE PS120 PROFESSIONAL WIDE BAND OSCILLOSCOPE

Lowest priced Wide Band 3 inch Scope anywhere. All hand wired.

Here it is, the scope that technicians, engineers and servicemen from coast to coast have been demanding. A portable wide band scope that can be used on the job anywhere, yet has the highest laboratory specifications for shop or lab. Cumbersome color TV sets, remote audio and organ installations and computers are just a few of the jobs that make owning a scope of this type so essential. Why consider a narrow band scope, when for only a few dollars more, this professional wide band sensitive scope equips you for any job.

• The PS120 provides features never before offered. Only two major controls make the PS120 as easy to use as a voltmeter. Even its smart good looks were designed for functional efficiency. New forward thrust design, creating its own shadow mask, and full width calibrated graph increase sharpness of wave form patterns. A permanent chromed steel carrying handle instead of untidy leather strap and a concealed compartment under panel for leads, jacks and AC

line cord make the PS120 the first truly portable scope combining neatness with top efficiency.

• Electrical specifications and operational ease will surpass your fondest expectations. Imagine a wide band scope that accurately reproduces any waveform from 20 cycles to 12 megacycles. And the PS120 is as sensitive as narrow band scopes... all the way. Vertical amplifier sensitivity is .035 volts RMS. The PS120 has no narrow band positions which cause other scopes to register erroneous waveforms unexpectedly. Another Sencore first is the Automatic Range Indication on Vertical Input Control which enables the direct reading of peak-to-peak voltages. Simply adjust to one inch height and read P-to-P volts present. Standby position on power switch, another first, adds hours of life to CRT and other tubes. A sensitive wide band oscilloscope like the PS120 has become an absolute necessity for trouble shooting Color TV and other modern circuits and no other scope is as fast or easy to use.

### SPECIFICATIONS

#### WIDE FREQUENCY RESPONSE:

Vertical Amplifier—flat within 1/2 DB from 20 cycles to 5.5 MC, down—3 DB at 7.5 MC, usable up to 12 MC.

Horizontal Amplifier—flat within —3 DB from 45 cycles to 330 KC, flat within —6 DB from 20 cycles to 500 KC.

#### HIGH DEFLECTION SENSITIVITY:

	RMS	P/P
Vertical Amplifier—Vert. input cable	.035V/IN.	0.1V/IN.
Aux. vert. jack	.035V/IN.	0.1V/IN.
Through Lo-Cap probe	.35V/IN.	1.0V/IN.
Horizontal Amplifier—	.51V/IN.	1.44V/IN.

#### HIGH INPUT RESISTANCE AND LOW CAPACITY:

Vert. input cable	2.7 Meg. shunted by approx. 99 MMF
Aux. vert. input jack	2.7 Meg. shunted by approx. 25 MMF
Through low cap. probe	27 Meg. shunted by 9 MMF
Horiz. input jack	330 K to 4 Meg.

#### HORIZONTAL SWEEP OSCILLATOR:

Frequency range—	4 ranges, 15 cycles—150 KC
Sync Range—	15 cycles to 8 MC—usable to 12 MC

#### MAXIMUM AC INPUT VOLTAGE:

Vertical input cable—	} 1000 VPP (in presence of 600 VDC)
Aux. vert. jack—	
Lo-Cap probe—	
Horiz. input jack—	

#### POWER REQUIREMENTS:

Voltage—	105-125 volts, 50-60 cycle
Power consumption—	On pos. 82 watts
	Stby. pos. 10 watts

SIZE: 7" wide x 9" high x 11 1/4" deep—weight 12 lbs.

The PS120 is a must for color TV servicing. For example, with its extended vertical amplifier frequency response, 3.58 MC signals can be seen individually.



**SENCORE**  
ADDISON 2, ILLINOIS

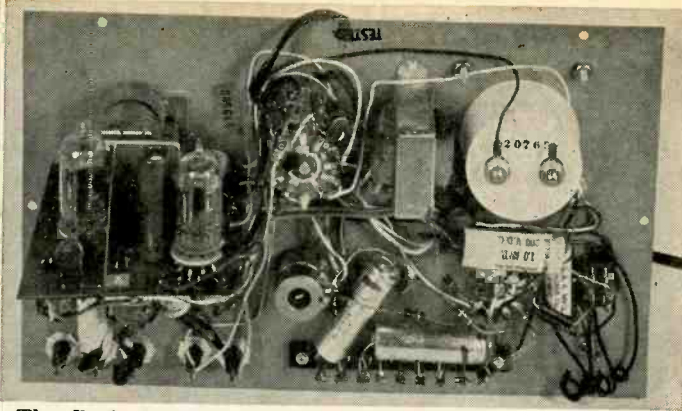
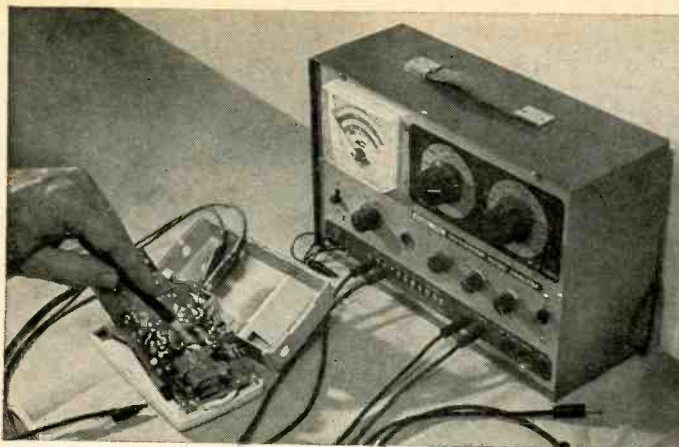

The B & K 960 transistor radio analyst tracks down a circuit fault (left). Back panel view above.

The af generator uses the other half of the 12AU7. The circuit constants are such that it oscillates at about 2,000 cycles. The audio can be taken off at the AUDIO OUTPUT jack for signal-tracing audio stages. A winding on the oscillator coil provides a low-impedance signal for testing speakers at the VOICE COIL jack. The audio also modulates the rf signal when desired.

The tapped, metered power supply is unusually versatile. Taps are provided in 1.5-volt steps along a low-resistance bleeder network (Fig. 8). These taps make it possible to test any radio, even those using a tapped battery power supply, and, since the supply is well filtered and low-impedance, motor-boating should be virtually eliminated.

(Higher-impedance test power supplies sometimes cause radios that rely on the battery as part of the filter system to motorboat.)

The power supply current meter has two ranges: 0-15 ma and 0-150 ma. They are selected by a front-panel switch. These are ideal ranges for checking almost any transistor radio.

Since nearly all transistor radios use 9 volts or less, the 12-volt maximum of this supply is adequate for just about any radio that will hit your shop.

The vtvm has two ranges: 0-1.5 and 0-15 volts. This will take care of all voltages you're likely to encounter in transistor service. The 1.5-volt range is ideal for checking bias.

The ohmmeter has only one scale.

It reads 1,000 ohms at center scale and has a full-scale reading of 1 megohm.

### The in-circuit test

The unique feature of the Model 960 is the "in-circuit" transistor and stage tester that utilizes only a single-wire test probe. Here's how to work it. Switch on the Analyzer and set the function switch to IN CIRCUIT. This switches the meter into a bridge circuit as shown in Fig. 9. Connect the radio to be tested to the power supply, observing correct polarity. Adjust the control marked IN-CIRCUIT METER SET until the meter reads in the green calibrate area. Switch the PNP-NPN switch to the type of transistor stage to be tested. Touch the IN-CIRCUIT TEST probe

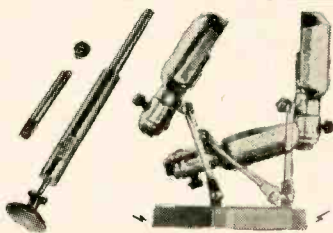

### SHORT CUTS FOR SERVICE PROFITS!

**FONO-MAGIC**—a liquid compound of Special Rubber and precious carbide particles forms a live rubber coating on metal phono drive parts... stops slipping and dragging caused by crystallized rubber drive wheels. Contents are equivalent to the replacement of 100 idler wheels; will not wear off. dealer net... \$1.95

**TROLMASTER**—cleans and lubricates TV-Radio controls in 60 seconds from the front of set without removing chassis or back from cabinet. Solid brass construction. dealer net... \$3.95

**MAGNA-LITE**—superpowerful magnet clamps light to chassis, transformers, brackets, etc. Does away with flashlight servicing. 3-way swivel action puts light exactly where needed. net... \$5.95

**HUMI-KUP 2 SET COUPLERS**—hermetically sealed for outdoor installation; all inductive circuitry; skin packaged for self service sales. List \$3.95. dealer net... \$1.95

**KLEENTROL MAGIC SOLVENT**—approved by C.A.A.; contains no Carbon-Tet: non-flammable; will not harm finishes of wood, metal, or acetate parts. net (5-oz. spray can incl. injector tube) \$1.25 pint size... \$1.95 net.

**CARDIO MASTER**—super powerful magnetic device designed to hold a portable transistor radio in the area of a car's windshield and make it operate as a car radio. List Price \$4.95 dealer net \$2.97

**METAL STROBE**—handy all metal speed determining tool that lasts a lifetime; 4 speed design. dealer net... .99

**NU-SHAFT**—repairs broken clock-radio shafts without removing set from cabinet. Kit includes 7 Nu-Shafts and 21 replacement knobs of asst. colors. net... \$1.95

Sold at better jobbers everywhere—Detailed literature upon request. Write Dept. P-10  
**R-COLUMBIA PROD. CO., INC.** 2008 St. Johns Ave. Highland Park, Ill.

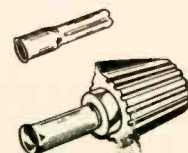
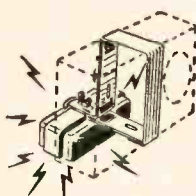

Now Available! EASY-TO-ASSEMBLE

## FAIRCHILD KITS

### FAIRCHILD 412-1K Turntable Kit

For the astute audiophile who dreams of owning only the finest... this famous FAIRCHILD 412-1K

Turntable Kit is exactly like the FAIRCHILD 412, its assembled counterpart, including locked-in synchronous 33 1/3 speed, 8 lb. turntable and exclusive FAIRCHILD Double-Belt Drive. With mounting board. KIT \$74.95; Assembled \$95.00



### FAIRCHILD COMPANDER® Model 510K

Dynamic Realism in kit form! Acclaimed by audio experts, the FAIRCHILD COMPANDER restores to playback the dynamic realism that is necessarily controlled in recording or broadcast. Can also be used as a compressor for background music. KIT \$59.95; Assembled \$75.00



### FAIRCHILD 440-2K Turntable Kit

A single-belt drive, two-speed, 33 1/3 and 45 rpm. turntable; characteristics similar to the famous FAIRCHILD 412. Kit includes fast speed change, the FAIRCHILD Speed Sentinel, low low rumble and almost immeasurable wow and flutter. With mounting board. KIT \$58.00; Assembled \$69.95

All these FAIRCHILD KITS are available at your audio dealer. Write for complete details.

## FAIRCHILD

RECORDING EQUIPMENT CORPORATION  
10-40 45th Ave., Long Island City 1, N. Y.



to the base of the transistor. This should increase transistor current. (The probe supplies a negative voltage for p-n-p transistors and a positive voltage for n-p-n's.) Since the meter is in a balanced circuit, even a slight increase in overall current will deflect it up scale —if the transistor and its dc circuit are operative. If the meter *doesn't* deflect up scale, either the transistor or its dc circuit is defective.

Although this in-circuit test does

not tell absolutely whether a stage is good, it certainly indicates if the stage is bad. For example, if the meter deflects up scale in an i.f. stage, you know that the dc circuit of the stage is good and that the transistor responds to bias. It does not tell you whether the gain of the transistor or stage is adequate. On the other hand, if there were no up-scale deflection, you would be certain that either the transistor or the dc circuit was defective. Then it

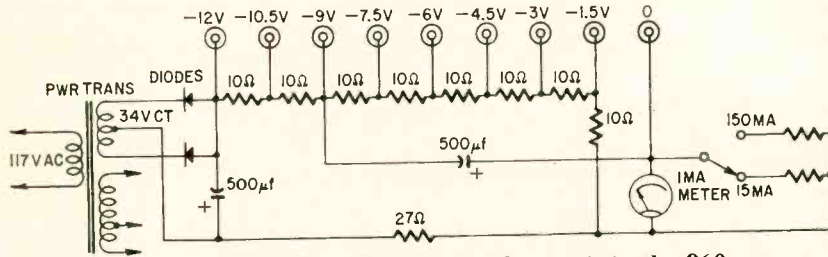

Fig. 8—Metered power supply circuit in the 960.

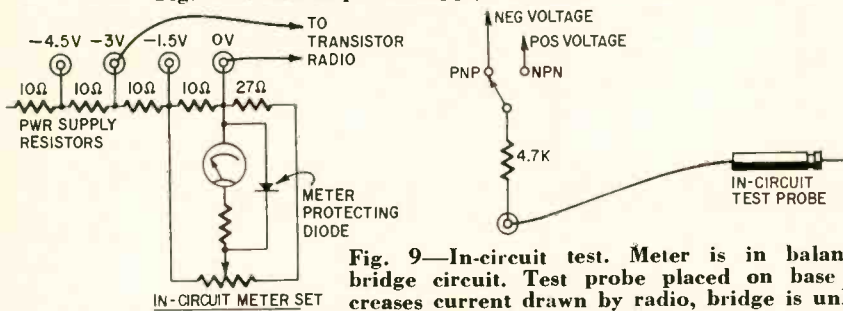

Fig. 9—In-circuit test. Meter is in balanced bridge circuit. Test probe placed on base increases current drawn by radio, bridge is unbalanced and meter reads up scale.

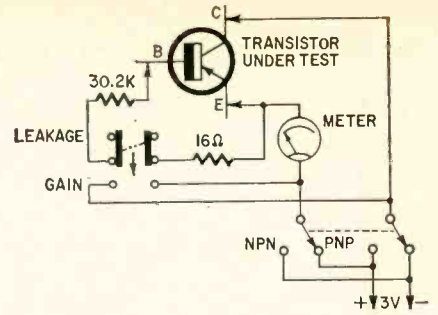

Fig. 10—Out-of-circuit transistor leakage-gain test.

would simply be a matter of pinpointing the specific bad part in that stage.

#### Out-of-circuit test

The model 960 also has an out-of-circuit test on the front panel. A simplified circuit is shown in Fig. 10. With the switch in the LEAKAGE position, an  $I_{CBO}$  (current from collector to emitter with base open) test is made. With the switch in the GAIN position, the transistor is forward-biased through the 30,200-ohm resistor, and a meter shunt is switched in. The meter reads emitter current and is calibrated in dc beta (gain).

The B & K unit looks like a good instrument for anyone servicing transistor radios. We checked out several radios with it as our sole test instrument. In every case tried, we were able to find the trouble without resorting to any other equipment. **END**

# ALL NEW SENCORE component substitutor



MODEL RC121

## All your favorite Sencore Substitution Time-Savers in One Compact Unit

A complete range of carbon resistors, wire wound power resistors, capacitors, electrolytics, and universal selenium and silicon rectifiers.

Imagine, all of these hard to locate parts at your finger tips for on the spot substitution. Say goodbye to messy, crumpled parts, unnecessary unsoldering and soldering of components for testing purposes only. Save valuable servicing time and be sure, by substituting.

NEW . . . each section operates independently with a value close enough for every substitution need. Components in each section are isolated from chassis and from the other sections. For example, a complete power supply can be constructed using the RC121 Components only.

NEW . . . dual electrolytics provided. A new circuit enables you to substitute up to 25 single electrolytic values or 9 duals. Exclusive surge protector provides protection on both singles and duals for both you and the circuit.

You save space and money. Equivalent Sencore substitution-pieces purchased individually (H36, PR111, RS106, ES102) cost you \$54.00

RC121 (all hand wired, all American made) only **3995**  
RC121K (Kit) . . . . . 27.95

Now in stock at your Sencore Distributor. See him today!

**SENCORE**  
ADDISON 2, ILLINOIS

# MIDGET 4-channel CB R/C receiver

*A packaged amplifier unit makes  
this tiny receiver practical*

By E. L. SAFFORD, JR.

**T**HE Centralab TA-12-B, a tiny packaged amplifier, makes possible a very small four-channel radio-control receiver for 27 mc. Requiring only 1.5 to 1.75 volts to operate (a penlight, mercury or wet cell) and only a hair larger than a standard reed decoder, the receiver can be used in model airplanes, model trains or very small model boats.

The relative size of the TA-12-B can be seen in the photos. It consists of four transistors in a high-gain, very stable circuit, with provisions for a volume control. Its circuit and frequency response curve are shown in Fig. 1. Six wire leads provide the connections. A metal cover shields the circuitry. It can be mounted in any position. The output, 0.5 mw, is large enough to drive any power stage. Its price is high, but the unit is small!

### Receiver operation

Although the receiver to be described here can be used as either a single- or multichannel type, tones are required. In the single-channel application, any tone from 300 to 1,000 cycles will give good performance. The relay is a Jaico 100-ohm type requiring about 12 ma to close and open-

ing at 8 ma. Without signal, the 2N109 (Fig. 2) draws about 15 ma; with signal, about 5 ma.

For multichannel operation, the relay is converted into a reed decoder. Small pieces of a wristwatch spring are so positioned over the pole piece that when tones of 200, 225, 250 and 280 cycles per second are received, each reed vibrates, the shortest with the highest frequency and the longest with the lowest frequency. As each reed vibrates, it touches a fixed contact positioned above it, making an intermittent connection that can make a second relay or transistor operate. The second relay or transistor causes motors, escapements or other power devices to furnish physical motion. Reed tones must be exact and are governed by the length of the pieces of watch spring.

### Circuit details

The superregenerative detector stage is a simple, straightforward, standard circuit using a Philco AO-1 transistor (Fig. 3). The coil is wound on a ¼-inch slug-tuned CTC form. The audio voltage output is developed across the 1,000-ohm resistor in the lead to the negative 1.5-volt line. Since the amount of superregeneration is small, I used an oscilloscope to test the operation of this part of the circuit.

Connect scope leads across the 1,000-ohm resistor.

When the power is off, the scope line should be thin and narrow. With power connected to the receiver and the stage working, the line on the scope will broaden, indicating the presence of rf. The widened line may be from ¼ to ½ inch higher than the one without power. If a transmitter is turned on and a tone transmitted, you can see the modulation on the wider picture when the receiver is properly tuned.

The two 47,000-ohm resistors and .001-μf disc capacitors form a quench filter for the input. A second quench filter, a 5.6-μf 6-volt capacitor, is placed across a 27,000-ohm resistor at the TA-12. (The 5.6-μf capacitors are not available everywhere. In most cases, 5-μf or 6-μf units should do the job satisfactorily. — *Editor*). This gives a good, pure sine wave for tones up to about 600 cycles. Use a smaller capacitor if higher-frequency tones are to be received.

The 2N109 stage is straightforward. Base bias resistor (R8) may be any value from 5,000 to 10,000 ohms. The lower value gives a higher static current and is better for single-channel operation. Be sure to connect the 5.6-μf coupling and filter capacitors with the polarity shown. Also, do not

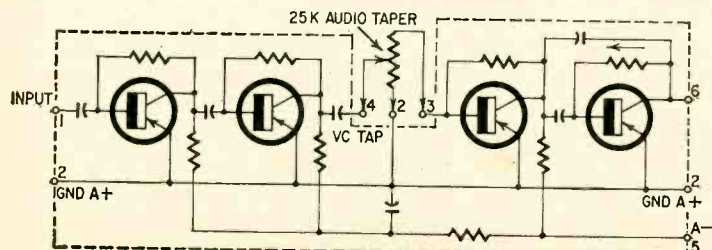
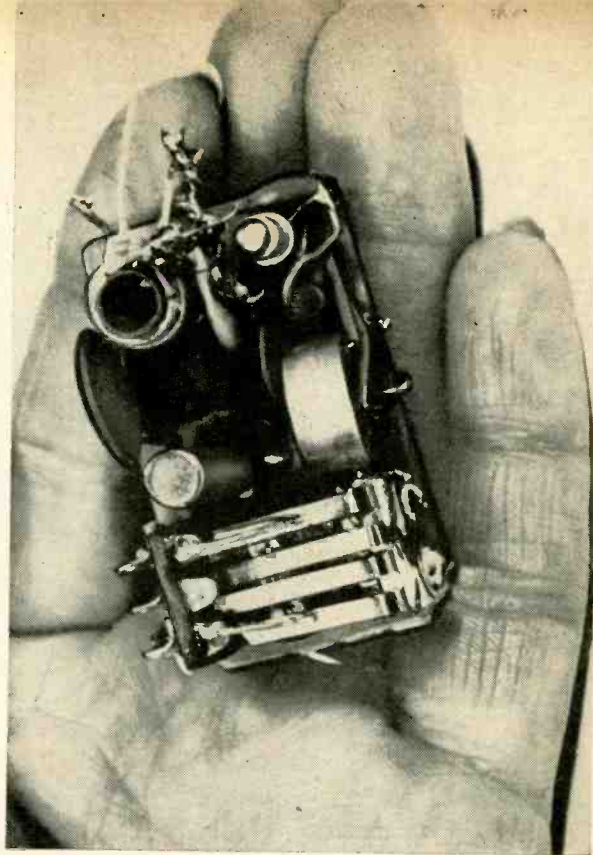
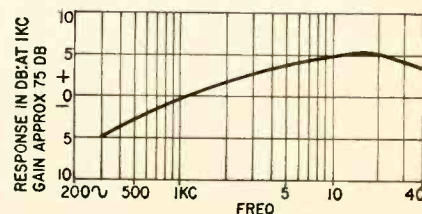

Fig. 1—Circuit of the TA-12-B, a packaged 4-transistor amplifier and its frequency response chart.



# Find it and Fix it in 1/2 the time!

EASILY SOLVES "TOUGH DOGS"... INTERMITTENTS... ANY TV TROUBLE



MODEL 1076

## TELEVISION ANALYST

BLACK & WHITE AND COLOR

*Just As Easy to Use As a VOM!*

**By Easy Point-to-Point Signal Injection, You see the Trouble on the TV Screen and Correct it—Twice as Fast and Easy!**

Simplified technique stops lost hours never recovered on "tough dogs", intermittents, and general TV troubleshooting. This one instrument, with its complete, accurate diagnosis, enables any serviceman to cut servicing time in half... service more TV sets in less time... satisfy more customers... and make more money.

With the Analyst, you inject your own TV signals at any time, at any point, while you watch the generated test pattern on the picture tube of the television set itself. This makes it quick and easy to isolate, pinpoint, and correct TV trouble in any stage throughout the video, audio, r.f., i.f., sync and sweep sections of black & white and color television sets—including intermittents. No external scope or waveform interpretation is needed. Checks any and all circuits—solves any performance problem. Gives you today's most valuable instrument in TV servicing—proved by thousands of professional servicemen everywhere.

Available on Budget Terms. As low as \$30.00 down.

Net, \$29995

### SIMPLIFIES COLOR TV SERVICING, TOO

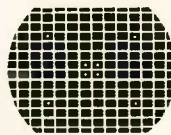

Enables you to troubleshoot and signal trace color circuits in color TV sets, or facilitate installation.



Generates white dot, crosshatch and color bar patterns on the TV screen for color TV convergence adjustments.



Generates full color rainbow display and color bar pattern to test color sync circuits, check range of hue control, align color demodulators. Demonstrates to customers correct color values.

### Time-Saving, Money-Making Instruments Used by Professional Servicemen Everywhere



Model 960 Transistor Radio Analyst



Model 360 V O Matic Automatic VOM



Model 375 Dynamatic Automatic VTVM



Model 700 Dyna-Quik Tube Tester



Model 440 CRT Rejuvenator Tester

See Your B&K Distributor or Write for Catalog AP20-E



### B & K MANUFACTURING CO.

Division of DYNASCAN CORPORATION

1801 W. BELLE PLAINE AVE. • CHICAGO 13, ILL.

Canada: Atlas Radio Corp., 50 Wingold, Toronto 19, Ont.

Export: Empire Exporters, 277 Broadway, New York 7, U.S.A.

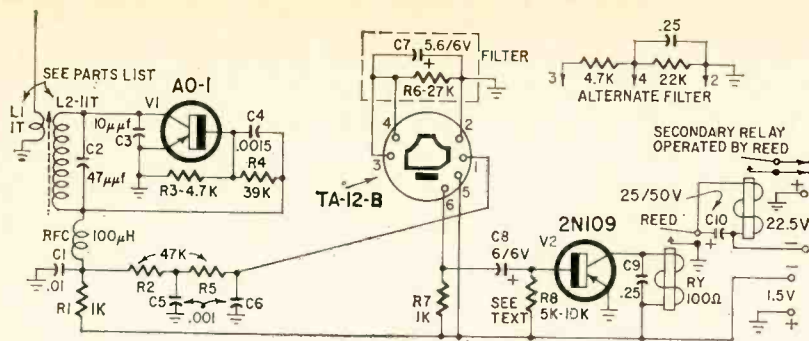

Fig. 2—Circuit of the complete 4-channel receiver.

- C5, C6—001  $\mu$ f, ceramic
- C7, C8—5.6  $\mu$ f, 6 volts, miniature electrolytics (Solid Tantalum Texas Instruments capacitor available from Lafayette Radio and Allied Radio)
- C9—0.25  $\mu$ f, ceramic
- C10—25  $\mu$ f, 50 volts, electrolytic
- All capacitors 6 volts or higher
- L1—1 turn No. 28 enameled wire spaced  $\frac{1}{16}$  inch on CTC (Cambridge Thermionic Corp.) LSM  $\frac{1}{4}$  inch red dot coil form with core. Winding length  $\frac{1}{2}$  inch.
- RFC—100  $\mu$ H
- RY—100 ohms (Jaico relay coil or relay, Jaidinger Mfg. Co., 1921 W. Hubbard St., Chicago 22, Ill.)
- V1—AO-1 (Philco)
- V2—2N109
- Batteries 1.5 and 22.5 volts
- Miscellaneous hardware

- Miniature transistor amplifier (Centralab TA-12-B)
- R1, R7—1,000 ohms
  - R2, R5—47,000 ohms
  - R3—4,700 ohms
  - R4—39,000 ohms
  - R6—27,000 ohms

- R8—5,000 to 10,000 ohms (see text)
- All resistors  $\frac{1}{4}$ -watt 10%
- C1—0.01  $\mu$ f, ceramic
- C2—47  $\mu$ f, ceramic
- C3—10  $\mu$ f, ceramic
- C4—0.015  $\mu$ f, ceramic

omit the 0.25- $\mu$ f relay or reed bypass or reduce its value as this will cause trouble.

### Reed-unit construction

To convert the Jaico 100-ohm relay into a four-channel reed decoder, the following steps are necessary. First, carefully remove the relay armature and the bradded solder lug on the back of the relay frame. Next file down the top of the frame where the armature was pivoted until it is smooth and level and even with the top of the coil. Carefully remove the normally closed fixed contact from the front of the relay frame.

Cut a small piece of metal from a coffee can, about  $\frac{3}{8}$  inch long and  $\frac{1}{4}$  inch wide. Sand it bright. Bend it tightly together so it is  $\frac{3}{8}$  by  $\frac{1}{8}$  inch in size. Position it on top of the pole piece as shown in Fig. 4-a. Hold it

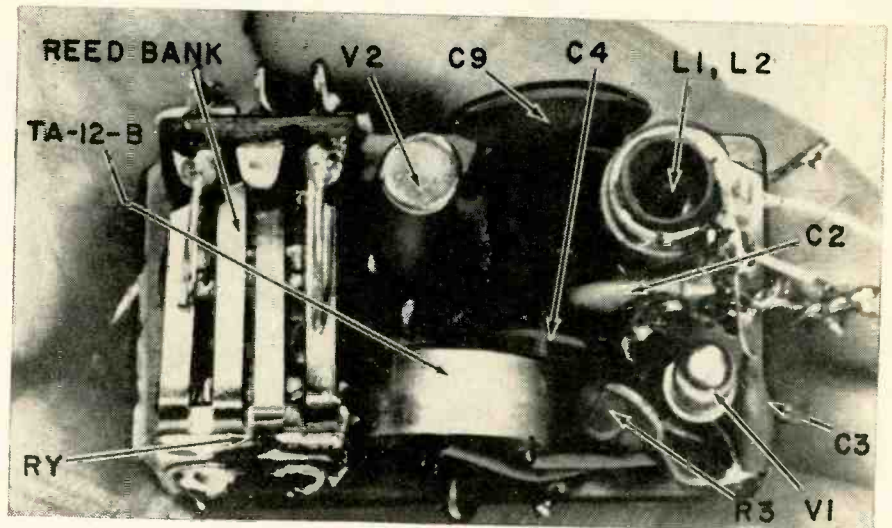

Top chassis view of the midget receiver.  
Other side of the receiver's chassis.

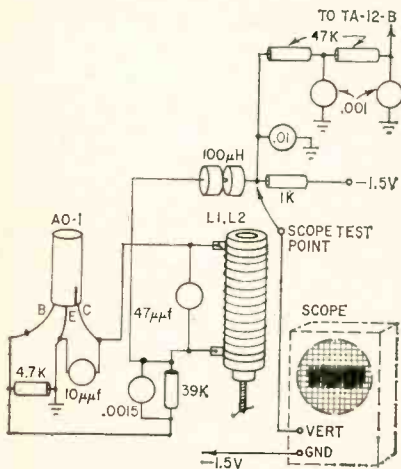
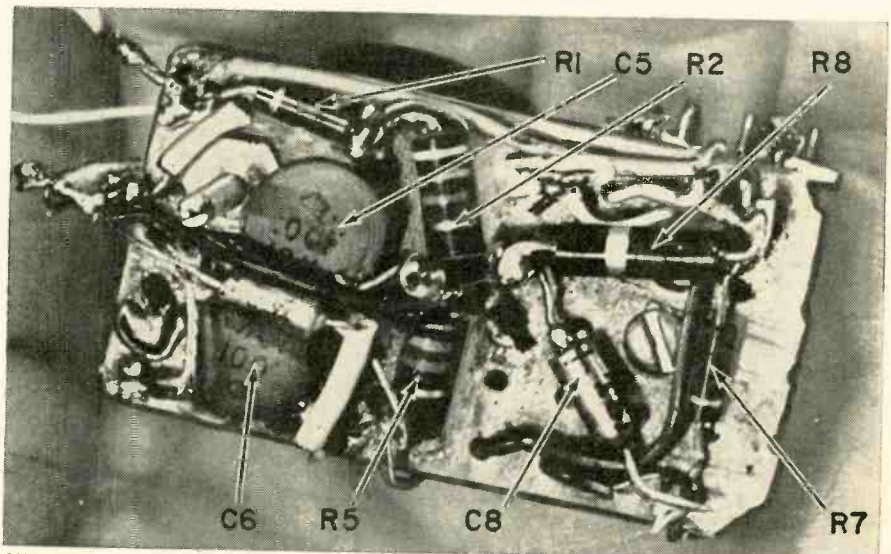

Fig. 3—Pictorial diagram of the receiver detector set up for oscilloscope test for superregeneration.

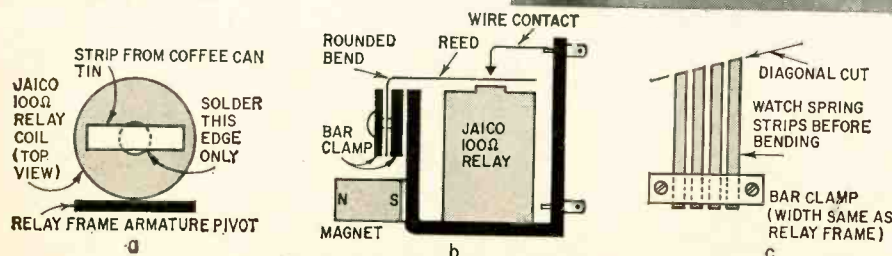
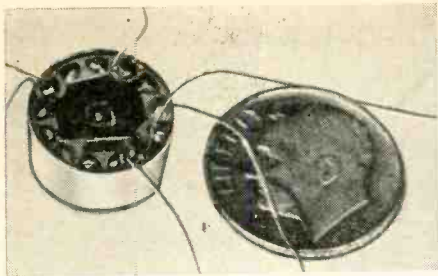

Fig. 4—Details of reed unit construction.

tight against the pole top and solder just the front edge. Be very careful to keep solder from running under the metal strip. Solder between the pole top and the strip will seriously impair the reed unit's performance. The metal strip must touch the pole top tightly. Now get a wristwatch spring. We used one from an old Timex watch. Straighten it out and sand both sides



One thin dime is larger than a TA-12-B amplifier.

bright. Cut four 1 1/8-inch pieces. Bend these 1/4 inch from one end, rounding the bend as in Fig. 4-b. The longer part should now be at least 3/4 inch long. Clamp the short ends between two small soft iron bars and file the inside of the bar smooth so it will fit tightly and firmly against the relay frame (Fig. 4-b).

Cut the long ends of the watch-spring strips diagonally as in Fig. 4-c. The sharper the diagonal, the wider the reed frequencies separate. The flatter the cut, the closer the reed frequencies. Then position the long part of the reeds 1/16 inch above the metal strip you soldered to the relay's pole piece.

Pressing the reed clamp bars tight against the relay frame, solder the edges to hold the bar in place. Do not let solder run between the bar clamp and the frame.

I found that positioning a small magnet like those in a dime store pot holder, as shown in Fig. 4-a, increases the reed vibration amplitude significantly. Try both ends of the magnet against the frame as one end will work better than the other.

When the proper tones are transmitted, and yours will be right around my values if you use the length reeds specified, the reeds will vibrate a full 1/16 inch up and 1/16 inch down. Now you can position fixed contacts over the reeds, above the pole piece, to complete the intermittent contact.

#### Reed-decoder improvement

The reed decoder can be improved if the magnet can be cut and positioned between the spring clamp bars and the

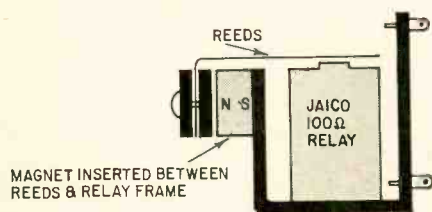

Fig. 5—Modification to improve the reed unit.

frame as shown in Fig. 5. For those who would like to build the receiver but not the reed unit, use the Min-X reed decoder, with a 200-ohm coil, obtainable through hobby shops. You can get 8 to 10 channels with this commercial item.

Any commercial radio control tone-type transmitter can be used with the receiver, provided its tones can be adjusted to the reed frequencies. END

# FEED-BAK STABILIZER

MODEL 8961

Designed for building-block installation, the Feed-Bak Stabilizer has screw terminals for input and output at 600 ohms, + 4 dbm unbalanced, with plug-in sockets for line-balancing transformers.

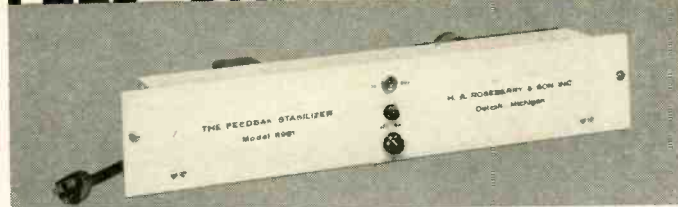

The Model 8961 Feed-Bak Stabilizer allows gain increases of from 6 to 12 db over level at which ringing occurs in a PA system operating in a space with irregular frequency response. Response is electronically flattened by shifting all frequencies 5 cps, thus avoiding regeneration and build-up of signal components at response peaks. There is no discernible altering of acoustical quality.

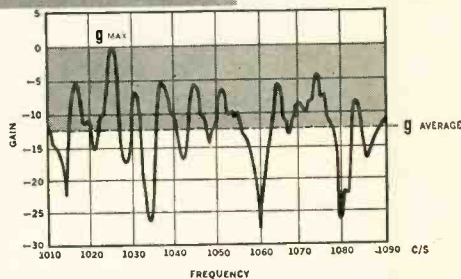

Solid line: typical room response across 1010 to 1090 cps range. Dotted line: typical efficiency of Feed-Bak Stabilizer in flattening room response by shifting peaks 5 cps.

**H. A. ROSEBERRY and SON, Inc.**

12750 MANSFIELD  
DETROIT 27, MICH.

ELECTRONIC AND COMMUNICATIONS ENGINEERS

## ORGAN SERVICING

End sticking keys, leaky condensers and rust—with electric DAMPP-CHASER® Organ Dehumidifier. Write for Dealer prices and specs. on letterhead. Damp-Chaser, Inc., Box 1641, Hendersonville, N. C.

## TAPE RECORDERS



HI-FI COMPONENTS  
SLEEP LEARN KITS

Unusual Values  
Free 1962  
Catalog  
**DRESSNER,**

**MERITAPE**  
Low cost, high  
quality recording  
tape, in boxes or cans.

1523RE Jericho Tpke, New Hyde Park, N.Y.

## YOUR NAME...

or any words... custom made for you, in raised white letters, on self sticking rugged vinyl tape. Choice of ten colors, or clear. Send 25¢ each, with Stamped self-addressed envelope.

**NAME TAPE**

Dept. 2 300 E. Tioga St. Phila., Pa.



## OUT OF SPACE?

You bet we'd be... if we were to tell you all about AUDION's 'Out of this World Hi Fi Values'.

Write for  
free  
Catalog

**audion**  
25-E Oxford Road  
Massapequa, New York

# TAPE HEADS DO WEAR OUT!

You'll never notice it—at first. But, gradually sound quality and high frequency response is lost as your tape heads wear. Sooner or later, your tape recorder loses its capability for peak performance.

**HAVE YOUR DEALER GIVE YOUR HEADS AN EXPERT CHECK!** Your dealer will test your heads... and, if needed, recommend the proper Nortronics heads for replacement. Ask him about the new Nortronics laminated heads... you'll hear the difference with Nortronics heads!

Send for **NEW** booklet "Head Care and Wear" Tells how to get maximum performance from your tape recorder

In addition, NORTRONICS provides the most complete line of kits for converting monophonic and 2 track stereo to 4 track stereo. Ask your dealer.

**Nortronics**

Send for **NEW** booklet "Head Care and Wear"

**NORTRONICS, COMPANY, INC.**  
Golden Valley, Minneapolis 27, Minn.

Enclosed is 15¢ for "Head Care and Wear"

Name \_\_\_\_\_  
Address \_\_\_\_\_  
City \_\_\_\_\_ State \_\_\_\_\_  
I own a \_\_\_\_\_ tape recorder

**SPOT CHECK  
HEADS IN  
2 MINUTES!**



- look for
- A. grooves or spots worn on surface of head
- B. a thin vertical black line dividing either poles

# soldering shortcuts

BY JOHN A. COMSTOCK

Many electronic technicians spend about half of their servicing time soldering and unsoldering circuit components. Because of this, much valuable time is wasted solving problems which crop up during various soldering jobs.

Here are several selected soldering shortcuts that will prove helpful. They will save time, trouble, and effort.



When replacing a defective part, how do you mark the location so you solder the replacement to the right lugs? Try color-coding the lugs with food coloring. A brush dipped in water removes the coloring quickly.



How do you shunt iron heat to avoid overheating delicate components? You could use various gadgets such as test clips, metal paper clamps, etc. Generally, a small pair of long-nose pliers with a rubber band around the handle works best.

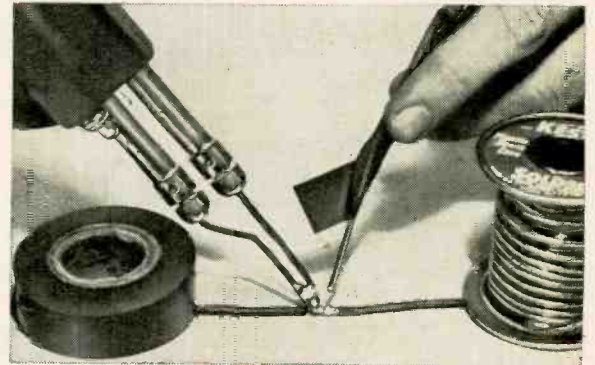

If a live circuit can't be disrupted while you solder, avoid shocks by wrapping solder with plastic electrician's tape. This also keeps finger grease, which sometimes hampers adhesion, off the solder.

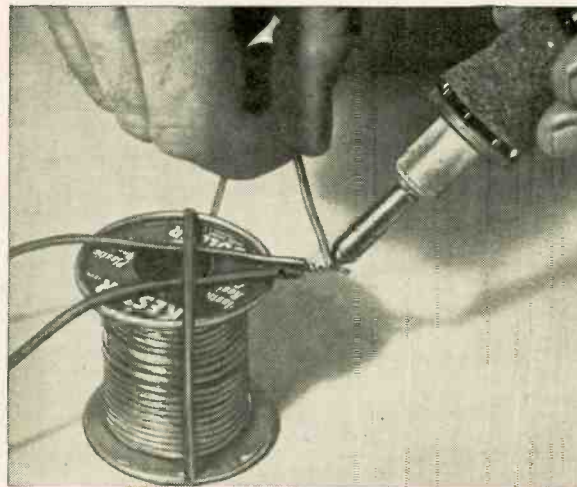

The technician's No. 1 problem is the need for a third hand to hold parts and wires. When they can be pinned down outside the circuit, a rubber band around the spool of solder will do the trick.



When small-gage wire solder is not available for work on transistors or printed circuits, hammer solder flat. This reduces solder's melting temperature and allows use of smaller iron and less part-damaging heat.

If you pick up your soldering gun, squeeze the trigger and discover the tip doesn't heat in the normal time, tighten tip-holding nuts or screws. If spotlights don't light, check for a blown or loose bulb.

END



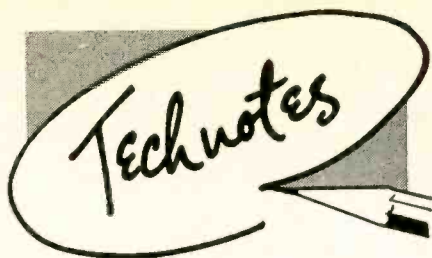

### PANEL MOUNTED METER ACCURACY

A meter intended for mounting on an iron panel will not give the same reading when it is removed from the panel. If the series or shunt resistors for the meter must be adjusted, do so with the meter mounted on the panel.

This also holds true for meters used on small portable meter cases. The meter should be a unit intended for such duty. Do not use such a meter too close to a massive iron structure or readings will not be accurate.—*Warren Roy*

### RCA CTC4, CTC5, CTC7 COLOR CHASSIS

Whenever the focus control goes on one of these chassis, install a 56,000-ohm 1-watt resistor in series with the arm of the replacement pot. If you use an RCA replacement part, you'll find that it is slightly different from the original and a variation on the mounting is needed.

Clip off the locating tab on the replacement pot. It won't line up with the locating hole in the chassis. This means you must be sure that the mounting nut is securely tightened. You will also find that the control terminals cannot be inserted through the mounting board. Instead, solder a short piece of bus wire to each terminal. These wires can then be inserted into the proper mounting board holes. (Fig. 2).

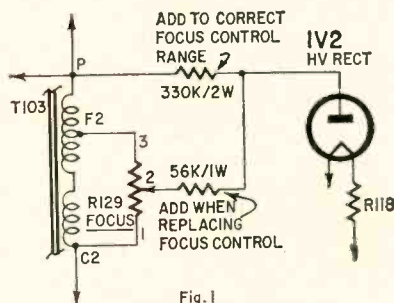

Fig. 1

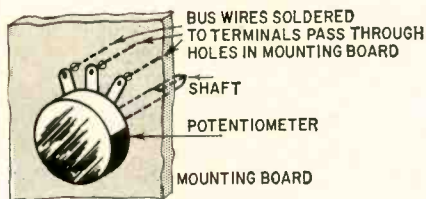

Fig. 2

After installation, if you find that the ranges of the focus control allows proper focus near the maximum clockwise position, add a 330,000-ohm 2-watt resistor as shown in Fig. 1—*RCA TV Service Tips*

### STEELMAN TRANSITAPE MODELS 7111-A, -B

*Symptom:* Short battery life, slow tape speed.

With a tape in place and running, the motor should draw about 100 ma. Greater current drain indicates improper flywheel pressure, a sticky pressure roller, too much pressure on the pressure pads or, once in a great while, an unsatisfactory motor.

The flywheel is the large brass wheel. Use your fingers and the holes in the casting to check for smooth rotation and end play. The wheel should have an endwise movement of .005 inch. This distance is barely but definitely discernible to the fingers. If necessary, loosen the rear-bearing lock nut, and back the bearing off. Try again. Too much end play will cause slippage (speed loss), and too little play will increase motor load needlessly.

Bring the bearing up very gently. It is made of sapphire

**Try This Handle!**

It's the New

# VACO

## Bull Driver



Here's the best handle you've ever seen on a screw driver!

Try it for grip. Ah! Real Comfort. Try it for ruggedness! Feel how that big handle lets you apply more power! Tough jobs go fast, easy!

The blade? It's made of the finest heat treated chrome vanadium steel to far exceed U. S. Torque Standards for strength.

Technicians have asked for this better, bigger handled driver and now VACO, America's Leading Screw Driver Manufacturer, has made it available. Try a Bull Driver today. There is nothing else like it!

**35%  
Bigger  
Handle**

**35%  
More  
Power**

**100%  
More  
Comfort**



Look For This Display At Your Jobbers

VACO COMPAR-O-GRAPH lets you COMPARE Bull Driver with a standard screw driver. See and feel the powerful difference!

VACO PRODUCTS COMPANY, 317 East Ontario St., Chicago 11, Ill.

In Canada: Vaco-Lynn Products, Ltd. and Atlas Radio Corp.

# SUPERIOR'S NEW MODEL 85 TRANS-CONDUCTANCE TYPE TUBE TESTER

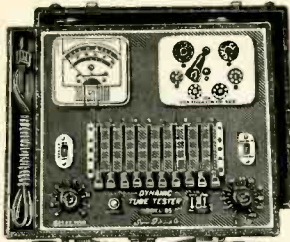

Model 85—Trans-Conductance Tube Tester, Total Price \$52.50  
 Terms: \$12.50 after 10 day trial, then \$8.00 monthly for 5 months if satisfactory. Otherwise return, no explanation necessary.

● **FREE FIVE (5) YEAR CHART DATA SERVICE.** Revised up-to-date subsequent charts will be mailed to all Model 85 purchasers at no charge for a period of five years after date of purchase.

Model 85 comes complete, housed in a handsome portable cabinet with slip-on cover. Only \$52.50

**SHIPPED ON APPROVAL  
 NO MONEY WITH ORDER—NO C.O.D.**

Try it for 10 days before you buy. If completely satisfied then send \$12.50 and pay balance at rate of \$8.00 per month for 5 months—No interest or finance charges added. If not completely satisfied, return to us, no explanation necessary.

MOSS ELECTRONIC, INC. All prices net, F.O.B. N.Y.  
 DEPT. D-933, 3849 Tenth Ave. New York 34, N. Y.  
 Please rush Model 85. If satisfactory, I will pay on terms specified. Otherwise I will return tester.

Name \_\_\_\_\_  
 Address \_\_\_\_\_  
 City \_\_\_\_\_ Zone \_\_\_\_\_ State \_\_\_\_\_

priced from \$109.50...  
 HAND-HELD, MOBILE, BASE STATION

## 2-WAY RADIO

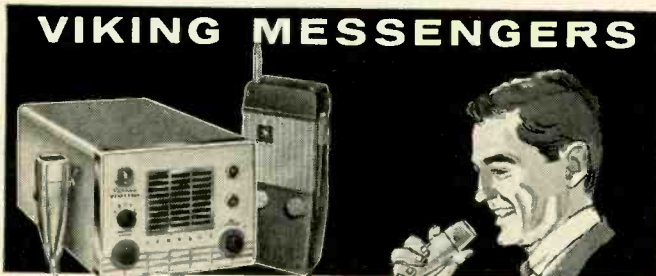

Now, 3 feature packed Johnson Messengers...  
 outperforming everything else in the field!

Compact, hand-held 100 milliwatt or 1 watt "Personal Messengers". Rugged and reliable—11 transistors, 4 diodes! Superheterodyne receiver and exclusive tuned RF amplifier gives twice the sensitivity and 40% more range than similar units with conventional circuitry—more output than similar units with same rated inputs!

For mobile or base stations—performance proved Viking "Messenger" punches your signal across the miles! High efficiency design makes full use of maximum allowable legal power. Excellent receiver sensitivity and selectivity. Automatic "squelch" control—5 channel coverage. Only 5 1/2" x 7" x 11 1/2", easy to install anywhere!

WRITE TODAY  
 for  
 information packed  
 4 Color Catalog



**E.F. JOHNSON COMPANY**

1105 10th Ave. S.W., Waseca, Minnesota

Please rush "Messenger" details to:

NAME \_\_\_\_\_

ADDRESS \_\_\_\_\_

CITY \_\_\_\_\_ STATE \_\_\_\_\_

Manufacturers of the world's most widely used personal communications transmitters.

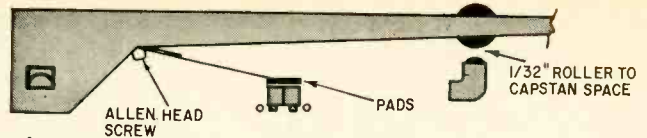

and too much pressure will crack it.

To check the pressure applied to the tape by the pressure arm, run the tape through and check motor current. Now lift the arm by hand, and observe the change in motor current. Stop the machine and test for roller freedom by turning the black rubber roller with your fingers. If it sticks or does not turn freely, replace with Steelman part No. 700047 and shaft No. 700067.

If the roller is satisfactory, check the pressure pads by watching them as you raise the pressure roller 1/16 inch from the capstan. After this distance the pads should leave the tape. If necessary, adjust by loosening the Allen-head screw found under the other end of the pressure arm (see diagram).

Note that, while too much pressure on the tape will reduce motor battery life considerably, too little pressure will cause erratic record and playback. Normal motor battery life is about 50 hours with intermittent Transistor operation.—Max Alth

### DuMONT RA-306

The set developed an intermittent loss of height. Monitoring the B-boost line showed it was affected whenever the height would shrink. The B-plus to the vertical oscillator is fed by bootstrap B.

Monitoring the B-boost at flyback terminal 3 showed

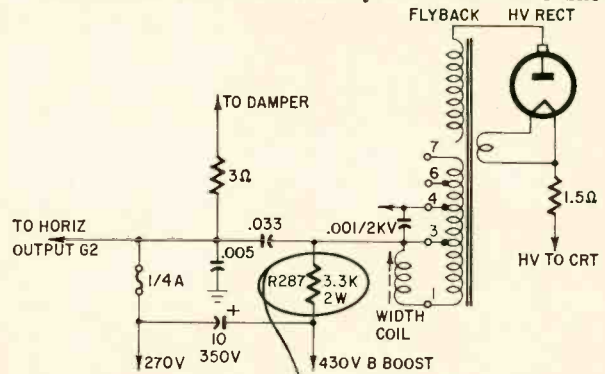

REPLACE WITH 5W UNIT

no appreciable change in B-boost with the height change. R287, the 3,300-ohm resistor in the B-boost line, was checked and its value was found to be off. Replacing the resistor put an end to this intermittent. We used a 5-watt replacement to prevent any recurrence.—Warren Roy

### FOCUS PRECAUTIONS

Both the focusing and ion-trap magnets affect the electron beam. Any appreciable adjustment of the focus magnet should be followed up by a readjustment of the ion-trap magnet.

Some TV sets have a funnel to help guide the screwdriver to the focus adjustment screw. If the screwdriver slips, it may move the ion-trap magnet slightly. If only a slight change is made, it may not be noticed immediately. As a general precaution, make it a rule always to check the adjustment of the ion trap after any focus adjustment.—Joe Shane

END

### WE BUY INDUSTRIAL TECHNOTES

RADIO-ELECTRONICS wants Industrial Technotes. These should cover equipment (including closed-circuit television) actually used in industrial work, or technotes on counters, controls and other apparatus whose users are largely industrial. Unillustrated Technotes pay \$5; circuit diagrams raise the price to \$9 and acceptable photos are worth \$7 each. Send your technotes from industry to Technotes Editor, RADIO-ELECTRONICS, 154 W. 14th St., New York 11, N. Y.



# NEW PRODUCTS

**TRANSISTOR AUDIOMETER, model ZA-100-T.** Portable, single-channel diagnostic hearing testing device, powered by eight Z-9 mercury batteries, one ZM-401. Automatic mercury shutoff switch; test meter indicates battery condition. Temperature-compensated circuitry includes transistor thermistor-stabilized Wien-bridge oscillator, tone interrupter switch with rise and decay time of 0.005-0.150 second, tone interrupter reverse switch. Masking control calibrated in levels of total sound intensity above .0002 dyne/sq cm. Continuously rotating frequency-selector dial, frequency accuracy within  $\pm 3\%$ . Measures frequencies 125-8,000 cycles air



conduction, 250-4,000 cycles bone conduction. 10% in. wide x 7 in. high 6% in. deep. 8 1/2 lbs. 2 TDH-39 headphones with MX41/AR cushions, headband, yokes, cord, bone-conduction receiver.—Zenith Radio Corp., 6001 W. Dickens Ave., Chicago 39, Ill.

**6-METER VFO, model HE-61.** Shielded tuning components, high-Q Clapp oscillator circuit. Operates in 4-4.5 mc range, output frequency 8 mc. Ferrite tuned coil output approximately 10 v. Use with any transceiver having standard 8-mc crystal. Cable with 5-prong power plug for units with correct input, instructions



for units without; cable and standard crystal plug for vfo input. Illuminated dial calibrated 50-54 mc. Single-knob planetary drive mechanism. Tube complement: 12BA6 oscillator, 0A2 voltage regulator.—Lafayette Radio Electronics Corp., 111 Jericho Turnpike, Syosset, N. Y.

**TRANSISTOR TESTER, model No. 36,560.** Tests p-n-p, n-p-n, power transistors, diodes and rectifiers. Measures Ico, beta gain, in and out of

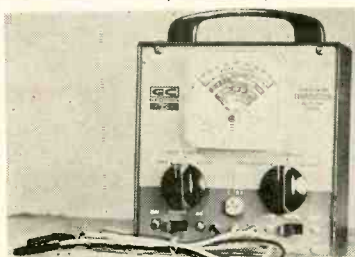

circuit. Short, leakage, gain tests. Wide-angle meter, transistor socket for out-of-circuit tests, zero adjustments on meter.—GC Electronics, 400 S. Wyman St., Rockford, Ill.

**VFO, model HG-10.** Covers 80-2 meters with each band separately calibrated on rotating drum type slide-rule dial. 28-1 gear-drive

vernier tuning. Epoxy-coated coils on ceramic forms for high stability. Double-bearing tuning capacitor. Heavy steel chassis, cathode-follower output. Spot switch for off-the-air tuning. Circuit designed for grid-block keying with manufacturer's DX-60, or cathode keying with other transmitters.—Heath Co., Benton Harbor, Mich.

**SELF-SERVICE TUBE TESTER, model 201-L.** Tests more than 1,200 types including nuvistors, compactrons, Novars, 10-pin, series-string, OZ4, 1-volt, electron-ray, hi-fi and foreign and 6 and 12-volt auto radio vibrators. Will



accommodate new types introduced in the future. Storage compartment holds over 600 tubes.—Mercury Electronics Corp., 111 Roosevelt Ave., Mineola, N. L.

**PORTABLE SOLID-STATE SCOPE, type 765, PortaScope.** Sensitivity 5 mv/cm, bandwidth 25 mc. Interchangeable dual plug-in range de-25 mc, 3 db down; additional plug-ins available

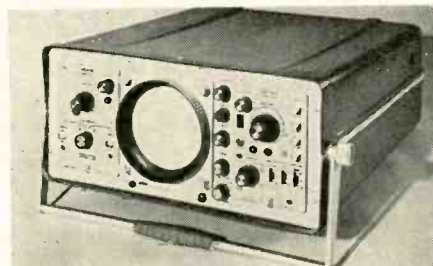

later. 27 lb (5 lb each plug-in). Model 766, bench type; model 767, rack-mounted.—Allen B. DuMont Labs., 750 Bloomfield Ave., Clifton, N. J.

**DC POWER SUPPLIES, Model EC-1, for**



**NOW  
YOU CAN BUILD  
A FINE  
Schober Organ  
FOR ONLY  
\$550**



You can assemble this new Schober Spinet Organ for \$550 — or half the cost of comparable instruments you have seen in stores. The job is simplicity itself because clear, detailed step-by-step instructions tell you exactly what to do. And you can assemble it in as little as 50 hours.

You will experience the thrill and satisfaction of watching a beautiful musical instrument take shape under your hands. The new Schober Electronic Spinnet sounds just like a big concert-size organ — with two keyboards, thirteen pedals and magnificent pipe organ tone. Yet it's small enough (only 38 inches wide) to fit into the most limited living space.

You can learn to play your spinet with astounding ease. From the very first day you will transform simple tunes into deeply satisfying musical experiences. Then, for the rest of your life, you will realize one of life's rarest pleasures — the joy of creating your own music.

For free details on all Schober Organs, mail the coupon now. No salesman will call.

THE *Schober Organ* CORPORATION

43 West 61st Street, New York 23, N. Y.

Also available in Canada and Australia.

**MAIL THIS COUPON TODAY**

The Schober Organ Corporation

Dept. 25-19  
43 West 61st Street  
New York 23, New York

Please send me FREE booklet and other literature on the Schober Organs.

Please send me the HI-FI demonstration record. I enclose \$2 which is refundable when I order my first kit.

Name.....

Address.....

City..... Zone... State.....

warmup, demonstration and checkout operations. Adjustable power source for mobile and marine AM and FM radio, 12-volt dc supply for lab research. Ripple 0.5% at 5 amps. Ampere output 0-5 adc. 3-position voltage adjustment switch, pilot light and wingnut output terminals. *model EC-2*, for auto radio and transistor portable servicing. Ripple 0.5% at 5 amps. Dc output 0-16 volts and 0-5 amps continuous. Variable voltage adjustment, voltmeter/ammeter, meter function switch, pilot light and insulated output binding posts.—*Electro Products Labs*, 4500 Ravenswood Ave., Chicago 40, Ill.

**TUBE CHECKER, Kit IT-21.** Checks all common tube types including compactron, Novar, nuvistor, 10-pin miniatures. Tests for quality on basis of total emission, and for shorts, leakage, open elements and filament continuity. Quality read on multi-colored meter scale. Multiple



filament voltages, adjustable cathode current, variable meter sensitivity and individual tube-element switching. Thirteen 3-position lever switches allow checking each tube element individually for open or short conditions. Roll chart, line adjust control.—*Heath Co.*, Benton Harbor, Mich.

**IN-CIRCUIT CAPACITOR TESTER, Realistic model TK-112.** Tests papers, mylars, ceramics, micas and tubulars for shorts or open. Direct measurement of electrolytic capacitor values, 4 to 400  $\mu$ f. All indications on EM84 eye tube. Coaxial cable with insulated alligator clips. Single



sequential test connects leads once for open or short reading. Short test reveals shorted capacitors with current shunting resistance as low as 10 ohms.—*Radio Shack Corp.*, 730 Commonwealth Ave., Boston 17, Mass.

**MINIATURE IF TRANSFORMERS, Part Nos. RTC-9284 to RTC-9295:** hollow hexagonal-hole cores for double or single-ended tuning. Mounted with snap fasteners attached to shields

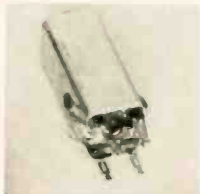

for positive ground connection without extra soldering. 262- and 455-kc input and output units, 4.5-mc input and interstage, plus 4.5-mc ratio detector. *Part Nos. RTC-9266 to RTC-9307:* With ground lugs for printed-circuit boards.—*Stancor Electronics Inc.* 3501 W. Addison St., Chicago 18, Ill.

**CAPACITANCE CHECKER, model 691.** 4 ranges for testing capacitors from 10  $\mu$ f to 1,000  $\mu$ f. Leakage tests for polarized and unpolarized units. Power factor test for electrolytics from 0-60%. Low-voltage bridge for checking electrolytics in transistor circuits.—*Jackson*

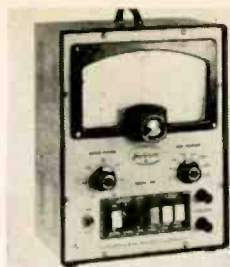

*Electrical Instruments Co.*, 124 McDonough St., Dayton, Ohio.

**SOLDER DISPENSER, Weller Kormat.** Speeds soldering by delivering solder to connection, even in tight corners. Keeps solder clean.

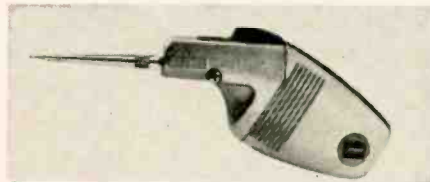

Protects heat-sensitive components from thermo-shock, as aluminum probe absorbs part of soldering heat. Takes solder 15 to 22 gauge. Holds solder in handle, or can be connected to external spool of solder.—*Weller Electric Corp.*, 601 Stone's Crossing Rd., Easton, Pa.

**SUPER CONTACT CLEANER, no 8680.** Heavy-duty contact cleaner with silicone addi-



tive, in 6-oz spray can.—*GC Electronics*, 400 So. Wyman St., Rockford, Ill.

**FM MULTIPLEX TUNER, model LT-81.** Sensitivity 2  $\mu$ v, 20-db quieting. Grounded-grid low-noise front end, triode mixer, 8-gang tuning



capacitor, tuned dual limiters, Foster-Seeley discriminator. Afc and nfc defeat, precision tuning meter. Response 20-20,000 cycles  $\pm$  1/2 db. Stereo separation 30 db, less than 1% harmonic distortion. Antenna input 300 ohms.—*Lafayette Radio Electronics Corp.*, 111 Jericho Turnpike, Syosset, N. Y.

**FM MULTIPLEX ADAPTER KIT, model KT-220,** for manufacturer's recent tuners or any quality wide-band FM or FM/AM tuner with



or without multiplex jacks. Prealigned coils. Self-powered, may be remotely connected to a tuner. Separation 30 db, 400 cycles. Distortion below 1%. Noise-limiter slide switch, on-off power slide switch with pilot light, separation control. Tubes: 12AU7, 6BN8, 12AX7, plus sili-

con rectifier. Shielded cable. All necessary components.—*Lafayette Radio Electronics Corp.*, 111 Jericho Turnpike, Syosset, N. Y.

**CB TRANSCEIVER, model TRC-5.** 117 vac, for base station, mobile or industrial operation. Voice signal 2 watts rf, frequency stability  $\pm$ .005%. 5 transmitting channels, front-panel switch. Superhet receiver tunable over entire band from 26.9 to 27.3 mc, plus single crystal-controlled receiver channel. High-impedance, ceramic push-to-talk mike with coiled cord.

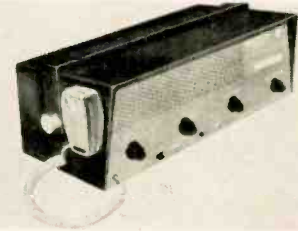

Transmitting and receiving crystals available for all CB channels, plus converters from 6 and 12 vdc.—*Radio Shack Corp.*, 730 Commonwealth Ave., Boston 17, Mass.

**CB TRANSCEIVER, model DN-348.** Receiver section: 5-tube superhet circuit with rf stage, squelch, noise limiter. Front-panel variable tuning dial selects any CB channel. I.f. 455 kc, sensitivity 1/2  $\mu$ v for 6-db signal-to-noise ratio. Selectivity 5 kc at 6 db down from peak response. Audio response 300-2,500 cycles,  $\pm$ 3 db. Input impedance 50 to 70 ohms. Transmitter



section: 5-watt nominal power input to final rf amplifier, nominal power output 3 watts. Operating frequency within .005% of crystal frequency over ambient temperature range of -20 to +130°F. AM plate modulation automatically limited to less than 100%. Output impedance 50-70 ohms.—*Daystrom Products Corp.*, Box 167, St. Joseph, Mich.

**VHF RADIO RECEIVER, model CRX-2 (illus).** FM reception 151-174 mc, for public service, land transportation, industrial communications, marine use. *Model CRX-1,* narrow-band, triple-conversion FM receiver, range 30-50 mc. *Model CRX-3,* dual-conversion AM receiver, range 108-135 mc, may be used for satellite communications. All units have built-in speaker, terminal strip for external speaker and internal-external speaker switch, adjustable squelch con-



trol, tuning control, channel-selector switch, antenna connector, ground legs, transformer power supply for 105/120 volts, 50/60 cycles ac. 13 1/2 in. x 5 7/8 in. x 8 3/4 in.—*Hallierafters Co.*, 4401 W. 5th Ave., Chicago 24, Ill.

**TV AMPLIFIER, model CAP-2.** For channels 2-13 and medium-level signal distribution in

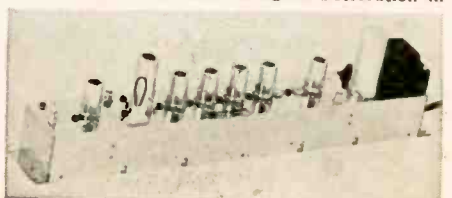

# Superior Performance

These two words . . . perhaps more than all others, describe the

## **INTERNATIONAL MODEL 100 EXECUTIVE CITIZENS BAND TRANSCEIVER**

Superior performance is the product of efficient design, precision engineering, top quality components and construction. From interior to the clean attractive lines of its exterior, the Model 100 gives you that extra measure of reliability.



### **Check these outstanding features . . .**

Crystal filter for minimizing adjacent channel interference. Built-in calibration circuit • 12-position crystal controlled transmit channel selector • Front panel microphone jack • Provision for connecting external speaker and S/meter • Tunable dual conversion superheterodyne receiver covering all 23 channels. • Two crystal controlled receive positions • Push-to-talk operation • Three way power supply for 6/12 vdc and 115 vac • Five watts plate input • Certified tolerance  $\pm .005\%$  • Brown cabinet with brown and silver panel • Dimensions: 5½" H. x 8½" W. x 9" D.

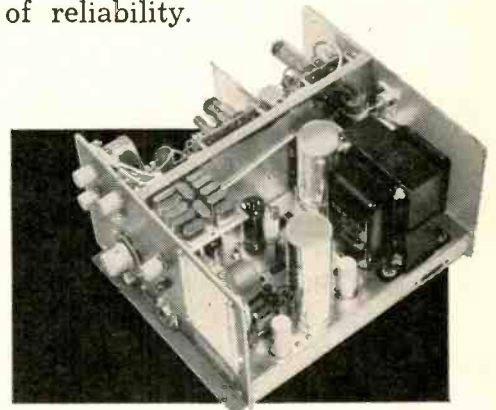

Complete with 1 transmit crystal, 1 receive crystal, new style ceramic microphone and coil cord **\$199.50**

### **External S/Meter and Speaker**

This external S/meter and speaker is the perfect companion for the Model 100. Constructed with the same clean lines and fine craftsmanship. Utilizes a high impedance vacuum tube volt meter circuit. Connects to socket on rear of transceiver. S/meter reads in three ranges.

Complete with interconnecting cable **\$49.50**



18 NORTH LEE • OKLAHOMA CITY, OKLAHOMA

The next time you visit your International dealer ask him for a demonstration of the Model 100 Executive and the system-engineered accessories. A complete catalog of International equipment and crystals may be obtained by writing International Crystal Mfg. Co.

community TV systems, educational and industrial installations. Gain 65 db with age disabled. Recommended output: Picture carrier 3 volts, sound carrier 1 volt. Input and output impedance 75 ohms; supply voltage 117 volt, 60 cycle, 40 watts.—Benco Television Associates, Ltd., 27 Taber Rd., Rexdale, Ontario, Canada.

**PORTABLE TV CONSOLE, model ST-1, Porta-Studio** for schools and industry. Transistorized camera and mike for audio and video reception. Combined with modulator into complete

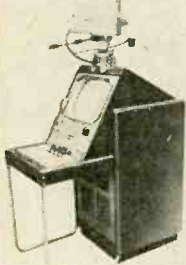

CCTV system, originating any channel from 2 to 13. Lighting equipment and 17-inch monitor. **Model ST-2:** two camera inputs, lights for two cameras and two 8-inch monitors.—Blonder-Tongue Labs., 9 Alling St., Newark, N. J.

**REPLACEMENT FLYBACKS** for Motorola TV sets. Stancor part No. **HO-342** replaces 24C740969 and 24C742676 in 50 Motorola models and chassis. **HO-343** replaces 24C744042 in 119

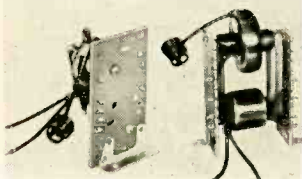

models and chassis. **HO-344** replaces Motorola 24K748397 and 24K754273-Z in 279 models and chassis.—Stancor Electronics Inc., 3501 Addison St., Chicago 18, Ill.

**FM-TV INDOOR ANTENNA, Brite-Site.** 5 feet when open, works when mounted out of



sight. Vinyl plastic, silver printed circuit.—RCA, Parts & Accessories, PO Box 654, Camden 2, N. J.

**FM-TV ANTENNAS, Combine series. Metropolitan Combine No. 1:** 40-in. square boom, 2 elements low-band TV, 3 elements collinear high-band TV, all-directional halo element on FM. **Suburban Combine No. 2:** 70-in. square boom,

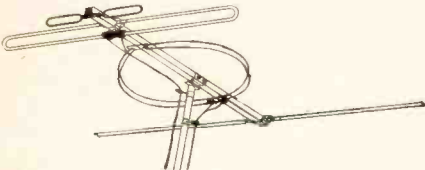

4 elements low-band TV, 10 elements collinear high-band TV, 3-element directional on FM. **Fringe Combine No. 3:** 100-in. square boom, 5 elements low-band TV, 15 elements collinear high-band TV, 4 elements directional on FM. All units require 2 separate transmission lines, no couplers, pre-assembled snapout construction.—Finney Co., 34 W. Interstate, Bedford, Ohio.

**10-ELEMENT YAGIS.** High-band units give continuous and overlapping frequency coverage

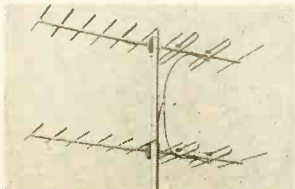

in 112- and 305-mc ranges, high gain, low vswr. Aluminum alloy tubing, heli-arc welded construction. **Model Y-102** for vhf communication fre-

quencies, **Y-103** for vhf plus high-band TV channels.—Taco, Box 38, Sherburne, N. Y.

**STEREO PREAMP-CONTROL CENTER, model PR2.** 15 inputs, 14 separate controls. Phonomix switch, loudness and volume controls,



phasing switch, equalized tape head inputs, separate recorder inputs, switched high-low cutoff filters and pure rectified dc on all filaments.—Bogen-Presto Co., PO Box 500, Paramus, N. J.

**STEREO RECEIVER KIT, model KU-45 Audio Center.** Combines AM/FM multiplex stereo tuner and 32-watt stereo amplifier. Dynamic side-band regulation reduces over-modulation and fringe-area distortion; afc locks in FM broad-



cast signal, prevents drift. Point-to-point wiring, prewired and prealigned FM front-end assembly. Push-button on-off switch, regular or reversed stereo switch, dual-concentric clutch type bass and treble controls. Amplifier Section: 32 watts continuous sine-wave power output; response  $\pm 1$  db, 30-16,000 cycles at rated power; harmonic distortion 1.0% at rated power; hum and noise better than -75 db; output impedances 4, 8, 16 ohms each channel, 8 and 16 ohms center channel. Tuner Section: FM sensitivity  $2\frac{1}{2}$   $\mu$ v usable IHFM sensitivity, 30-db quieting; i.f. bandwidth 200 kc, 3 db down; AM sensitivity 3  $\mu$ v, 10-db signal-to-noise ratio.  $4\frac{1}{4}$  x  $16\frac{1}{2}$  x 13 in. Supplied with parts, tubes, wire, solder, built-in AM loopstick and FM folded-dipole antennas.—Allied Radio Corp., 100 N. Western Ave., Chicago 80, Ill.

**AMPLIFIER/SPEAKER, model S-2300.** 8-watt push-pull amplifier, 8-in. woofer,  $3\frac{1}{2}$ -in. tweeter, built-in crossover network. Operates on any 117-volt, ac power supply, 50/60 cycles, 60

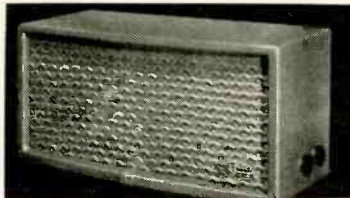

watts. Separate bass and treble controls, multi-purpose jack, for audio connection with sound source. Response 20-15,000 cycles; harmonic distortion less than 1%; hum and noise 55 db below rated output.—H. Herbert Orr Enterprises Inc., 714 Wesley St., Opelika, Ala.

**HI-FI TURNTABLE, Rondine 2, model R, 33 $\frac{1}{3}$  rpm only (illus.). Model R 320,** turntable with S-320 pickup arm. **Model R 320A,** turntable with AP-320 automatic pickup arm. Solid cast-aluminum turntables have hysteresis synchronous

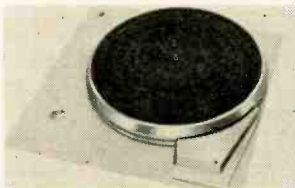

motor, noise level 57 db below average recording level, wow and flutter 0.15%. Minimum size for cabinet installation with stereo pickup arm  $15\frac{1}{2}$  x  $14\frac{1}{2}$  in. Height above deck 3 in., depth below deck  $4\frac{1}{2}$  in.—Rek-O-Kut Co., 38-19 108th St. Corona 68, N. Y.

**PICKUP ARM, model BTD-12S,** for 12-in. hi-fi turntables. Independent turntable leveling, resonant frequency below 16 cycles with ordinary

pickup cartridges, lower with high-compliance cartridges. Precision cueing device, integral with arm, for lowering and lifting arm without touching it. Adjustments: static balancing with damped counterweight for overall cartridge weights of 5-19 grams; spring-applied stylus force with knob calibrated from zero to 8 grams; vertical height (range 1% in.). Stylus overhang (range 7/16 in.) individually set for each cartridge. Vertical pivot design keeps stylus in vertical plane for each height adjustment. Bearing



friction below 1/10 gram in any direction at stylus. Arm  $12\frac{1}{2}$  in. overall, with mounting board for manufacturer's TD-124 and TD-121 turntables.—ELPA Marketing Industries, Thorens Div., New Hyde Park, N. Y.

**HI-FI SPEAKER SYSTEM, series AS-51.** 2 Jensen speakers, 8-in. woofer, compression type tweeter with flared horn. Range  $\pm 5$  db, 50-12,000 cycles. Built-in 1,600-cycle crossover network. Control adjusts power level of tweeter.

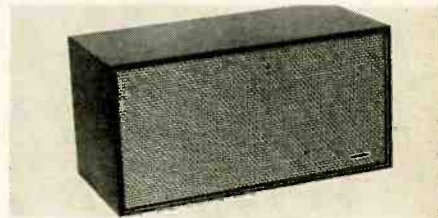

Speaker impedance 16 ohms, power rating 25 watts. Used with hi-fi amplifiers with as low as 3 watts output. Vertical or horizontal mounting.—Heath Co., Benton Harbor, Mich.

**COLUMN SPEAKER, Uniline CS-3.** 6 elliptical speakers, 2 tweeters. Response 150-10,000 cycles; vertical dispersion 22°, horizontal dis-



persion 120°. Power capacity 25 watts, impedance 16 ohms.  $48$  x  $7\frac{1}{2}$  x  $8\frac{3}{4}$  in.—University Loudspeakers, Inc., 80 S. Kensico Ave., White Plains, N. Y.

**MINIATURE DRY BATTERIES,** 44 types, for transistorized circuits. 8 power ratings from 3 to  $13\frac{1}{2}$  volts,  $1\frac{1}{2}$ -volt increments. Wafer Cell

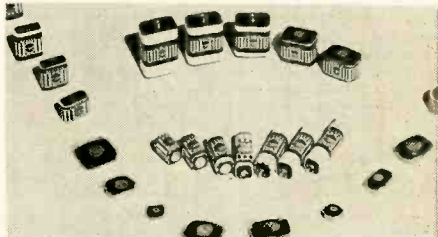

construction, sandwich of artificial manganese dioxide mix between disc-electrodes of zinc and carbon, heat-sealed in airtight ploidium envelope.—Burgess Battery Co., Freeport, Ill.

**WEATHERPROOF SPEAKER, Mini-**



# SPECIAL INTRODUCTORY OFFER

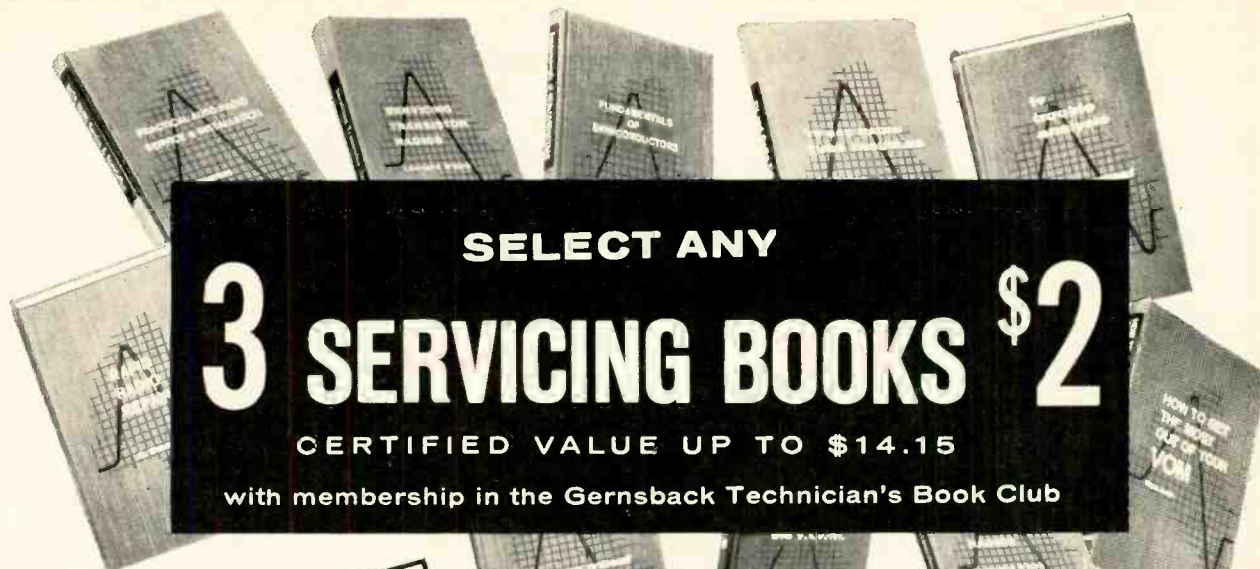

**SELECT ANY**  
**3 SERVICING BOOKS \$2**  
 CERTIFIED VALUE UP TO \$14.15  
 with membership in the Gernsback Technician's Book Club

**NO-RISK GUARANTEE**—if not satisfied return the books and cancel membership.

## WHY THIS SPECTACULAR OFFER?

Gernsback Library is making this offer to persuade more members to join the helpful Technicians Book Club. As striking as this offer is—it is only an introduction to the many advantages club members receive. The club gives you the chance to acquire at bargain prices—books by top technical writers on how to master fundamentals, learn new techniques that will help you get and stay ahead in electronics.

Here's the technical book buy of the year—not a collection of old or outdated volumes—but new books taken from the top of the Gernsback list of best sellers. Priced up to \$4.95 each—total value \$14.15.

## WHAT THE CLUB OFFERS YOU

- Selection of the best modern electronics books by first-rank authors.

- Tremendous savings on each book—Club prices range from \$3.25 up for books regularly priced at \$4.60 and more.
- Chance to select one or more valuable books per month.
- Opportunity to buy books not always available in your community.
- Attractive volumes—carefully printed—handsomely cloth bound.
- Preselection privilege. A newsy bulletin regularly describes each selection and the alternates in detail.
- Budget-coddling payments. You agree to accept as few as four additional books a year. You pay for the books only *after* you receive them—and then only at the special club price—discounts up to 27%.

Highlights from books you will be able to select in coming months

- What you need to know about modern TV.
- All about transistors.
- Math for the electronic technician.
- Getting more out of the oscilloscope.

- Complete book on electricity for technicians.
- Picture book to help you solve tough TV problems.

## HOW TO JOIN

- Mail the coupon below and start membership with any 3 of the books listed below. **SEND NO MONEY.** We'll bill you \$2—plus a few cents handling and mailing. If you're not satisfied with the books send them back and membership is cancelled.
- Each month you will receive a bulletin describing the choice of the month and alternates.
- You may select one or more books per month, or reject all books in a given month.
- You agree to accept only 4 additional books in the next 12 months. You may cancel anytime after that.
- Mail in the coupon below to Technicians Book Club, Dept. 42, 154 West 14th St., New York 11, N. Y. **SEND NO MONEY NOW** (unless you wish).

-----Choose the 3 books you want below for only \$2.00-----

- RAPID TV REPAIR.** By G. Warren Heath—Lists hundreds of tough TV problems alphabetically for quick and easy reference. Tells how to find 'em and fix 'em in minutes. Save servicing time with troubleshooting charts.
- THE VTVM.** By Rhys Samuel—Tells how the VTVM works, describes meter scales, probes, alignment, servicing. Offers dozens of new ideas on using the VTVM.
- TV & RADIO TUBE TROUBLES.** By Sol Heller—This new sure-fire symptom analysis method helps you trace any TV tube trouble to the source in minutes. A great servicing time saver.
- PRACTICAL AUTO RADIO SERVICE.** By Jack Greenfield—Covers transistor, hybrid FM and AM models. Compares auto with home radio servicing. Covers removal, installation, troubleshooting, power supplies, interference, suppression, tuner theory, etc.
- FUNDAMENTALS OF SEMICONDUCTORS.** By M. G. Scroggie—Thorough rundown on theory and practical applications of all kinds of

semiconductors—transistors, diodes, photocells, solar generators, Hall effect devices, and others. Application of principles in practical devices.

- SERVICING TRANSISTOR RADIOS.** By Leonard D'Airo—Ins and outs of the specialized knowledge needed to handle these tricky sets. Theory, instruments to use, pitfalls to avoid, alignment, hints on how to handle transistors.
- RAPID RADIO REPAIR.** By G. Warren Heath—An alphabetized "instant" guide to finding tough troubles in FM, transistor, hybrid auto sets and other modern receivers.
- SERVICING COLOR TV.** By Robert G. Middleton—Get ready for the color breakthrough! This book answers all your questions about chroma circuits, matrix testing, the flyback system test equipment. Contains numerous troubleshooting charts.
- HOW TO GET THE MOST OUT OF YOUR VOM.** By Tom Jaski—Get more mileage out of this versatile instrument. How to choose, build, work with and extend the use of the VOM.

## TECHNICIAN'S BOOK CLUB

Gernsback Library Dept. 62C  
 154 West 14th Street, New York 11, N. Y.

## ONLY 3 BOOKS TO A MEMBER PLEASE

Enroll me as a member of the G/L Technician's Book Club. Start my membership with the 3 books I've checked at the left for only \$2.24 (including postage). Each month send me a brochure describing the current selections which I may purchase at special discount prices if I wish. I understand that my only obligation is to purchase just 4 additional books within the next 12 months, and that I may cancel anytime thereafter. I also understand that I may cancel immediately, simply by returning these first 3 books within 10 days.

THIS OFFER GOOD IN U.S.A. & CANADA ONLY

NAME \_\_\_\_\_  
 ADDRESS \_\_\_\_\_  
 CITY \_\_\_\_\_ ZONE \_\_\_\_\_ STATE \_\_\_\_\_

**ANATOMY CLASS FOR DOCTORS  
OF RADIO AND TV**

**ABSENCE OF "GRID EMISSION"  
AND GAS DEMONSTRATES  
GOOD HEALTH OF TUNG-SOL  
IF AMPLIFIER TUBES**

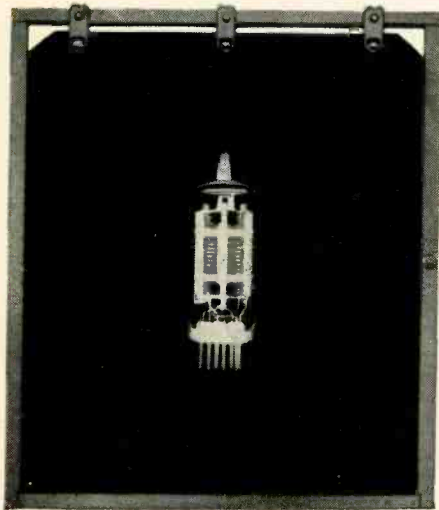

Radio and TV doctors know that IF amplifier tubes must be physically sound in order to enjoy a healthy long life. Because they operate in a high impedance circuit, internal cleanliness is vital to avoid gas distress. Grid emission, which displays identical symptoms, likewise must be carefully avoided. Tung-Sol's exacting engineering standards and rigid quality control in every step of manufacture assure vigorous long life. Tung-Sol IF amplifier tubes are made in a humidity-controlled, dust-free atmosphere. The operator's hands never touch the cathode coating. Gas evacuation and metal heating are done with critical precision by means of the most advanced equipment.

**GOOD MEDICINE FOR PROFITS**

One of the most highly recommended medicines for profits in radio and TV service business is the prescribing of tubes that are reliable. Cuts radio and TV set hospital visits. You can rely on Tung-Sol tubes. Here are some of the more popular Tung-Sol IF amplifiers: 1U4; 6AG5; 3AU6; 4AU6; 6AU6A; 12AU6; 3BA6; 4BA6; 6BA6; 12BA6; 3BC5; 4BC5; 6BC5; 6BH6; 6BJ6; 3CB6; 4CB6; 6CB6; 3BZ6; 4BZ6; 6BZ6; 12BZ6; 3DK6; 4DK6; 6DK6; 12AC6; 12BL6; 12AF6; 12EK6; 12EZ6; 18GD6A; 18FW6A



**TUNG-SOL**

the first name to ask for when ordering  
**IF AMPLIFIER TUBES**

TUNG-SOL ELECTRIC INC., NEWARK 4, N. J.

**Speaker.** Compact, weatherproof, dustproof. Self-contained steel enclosure. For use as extension, test, PA, intercom, or paging unit. Withstands extremes of humidity, temperature or shock. Provision for installing volume control and on-off switch.—Minneapolis Speaker Co., 3806 Grand Ave. So., Minneapolis 9, Minn.

**"LITTEL" KEY SWITCH, model MLK, 6 or 12 stations.** Key switches supported by common pivot rod of nickel-plated brass wire. Requires 2-3/32 in. depth behind mounting panel. 3-position lever type switch, or 2-position switch with

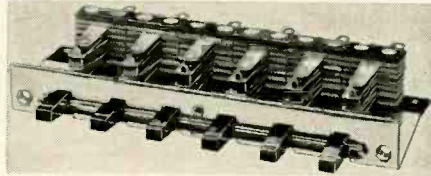

momentary or locking action. Choice of contacts: silver rated at 3 amps, 120-volt ac noninductive load. Palladium contacts on special order.—Switchcraft, Inc., 5555 N. Elston Ave., Chicago 30, Ill.

**SCREWDRIVERS** on rack display card. 3/16 x 4-in. and 1/4 x 4-in. round blade, No. 2 Phillips screwdriver, bonus driver with overall



length 2 1/2 in. Fluted, plastic handles, Vanadium steel blades.—Vaco Products Co., 317 E. Ontario St., Chicago 11, Ill.

**SURGISTOR, 1000 series.** Protects all tubes, silicon rectifiers, fuses, pilot bulbs and electrolytic capacitors from in-rush currents, by connection in series with power lead. Line



voltage initially reduced to one-third normal for about 10 seconds: full line voltage automatically restored by self-contained thermal switch.—Wuerth Products Corp., 1931 Moffett St., Hollywood, Fla.

**BATTERY ELIMINATOR/CHARGER, model P-25.** Eliminates need for batteries in transistor equipment during test and repair, simulates weak



battery conditions. Adjustable dc voltage, continuously variable, 0-25 vdc to 100 ma dc. Automatic center tap for transistor radios without output transformers. ±1.5-vdc fixed tap. Monitors voltage and current, recharges nickel cadmium batteries.—Pacotronics Inc., 70-31 84th St., Glendale 27, N. Y.

**FUSE PULLER** makes it easy to replace



fuses in hard to get at locations. One end takes long fuses, the other end short ones. Nylon molding resists grease, oil and other chemicals.—Bussman Mfg. Div., McGraw-Edison Co., St. Louis 7, Mo.

**WIRELESS INTERCOM, model FW-40** is an all-transistor 2-station system. Plug units into

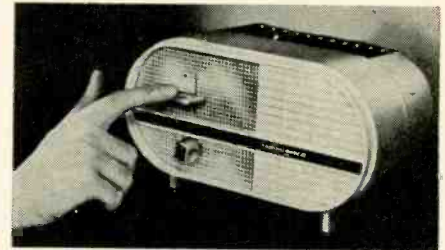

ac outlets. No warmup, no connecting leads. Additional single-station units can be added.—Fannon Electronic Industries Inc., 439 Frelinghuysen Ave., Newark 14, N. J.

All specifications are from  
manufacturer's data

**NEW  
LITERATURE**

CATALOGS • BOOKLETS • CHARTS

**INDUSTRIAL CATALOG.** 20-page, 2-color booklet offers printed circuitry, connectors, hardware, semiconductor products, industrial components, test instruments, communications equipment and technical books. Many illustrations. Request on company letterhead.—Allied Electronics, 100 N. Western Ave., Chicago 80, Ill.

**TECHNICAL BOOKLIST.** 32-page 2-color catalog contains data on 147 books on electronics, TV, radio, audio, computers, electricity, etc., with subject index.—Howard W. Sams & Co. Inc., Technical Book Div., 2201 E. 46 St., Indianapolis 6, Ind.

**PLANNING MASTER TV SYSTEMS.** 28-page manual gives detailed design information on various systems. Includes data charts and many illustrations.—Blonder Tongue, 9 Alling St., Newark, N. J.

**ULTRASONIC MACHINING** explained in 16-page illustrated *Bulletin 2-300*. Describes applications in drilling, slicing, engraving, trepanning and shaping hard and brittle materials. Full specs for manufacturer's impact grinders, plus tables of cutting rates for materials cut by ultrasonic techniques.—Raytheon Co., Commercial Apparatus & Systems Div., c/o Donald W. Hawes, 225 Crescent St., Waltham 54, Mass.

**STEREO HI-FI BROCHURE, AL-1302-3.** 3-color foldup booklet features mikes, tuners, amplifiers, speakers and speaker systems. Illustrated section covers recommended component arrangements.—Altec Lansing Corp., 1515 S. Manchester Ave., Anaheim, Calif.

**ELECTROMAGNETIC RELAYS** shown in 16-page *Catalog 62*. Illustrated sections feature high-performance, power, special-purpose, general-purpose, and telephone types, with full engineering data.—Potter & Brumfield, Technical Information Section, Princeton, Ind.

**TEST LEADS AND COAX CABLES** pictured in 4-page ordering guide. Shows shielded, unshielded and twisted pair, plus clips, ends, plugs, lugs and leads. Contains prices, testing specs and modifications.—Angler Industries Inc., 75 Winthrop St., Newark 4, N. J.

**STEREO HI-FI KITS, 8 models,** pictured in 4-page leaflet, with full specs. Also available leaflet on kit or assembled marine radio equipment, 6 units, with photos and specs.—Daystrom Products Corp., Box 167, St. Joseph, Mich.

**PHOTOCONDUCTOR DEVICES.** 4-page, 2-color leaflet describes special features, applications of manufacturer's photoconductor line. Gives technical data on one sample type.—Sylvania Electric Products Inc., 1100 Main St., Buffalo 9, N. Y.

# If you were not among the 10,123 kit-builders who received this first issue



...you're missing something

**RUGGEDIZED YAGIS**, over 100 types in ranges 30-500 mc, detailed in 16-page *Catalog 600*. Data include specific frequency, weight, nominal half-power beam width (degrees) for E and H planes, number of driven elements, maximum VSWR, maximum power input, nominal gain above isotropic source. Contains data on stacking systems, coaxial stacking lines, mounting kits for Yagis, skewing information for increased E-plane beam width, power-handling capability and wind-load specifications. Specs given on high-gain uhf screen antennas and special-purpose Yagis.—Technical Appliance Corp., Sherburne, N. Y.

**KIT BUILDER'S GUIDE**. Full-color 6-page leaflet shows complete line of amplifier and tuner kits, with specs for each. Includes full-page color photo of kit as supplied. Finished products pictured on cover.—H. H. Scott, Inc., Dept. P, 111 Powdermill Rd., Maynard, Mass.

**GENERAL CATALOG**. 264 pages of electron components and systems. Capacitors, resistors, test instruments, amateur gear, etc.—Dixie Radio Supply Co. Inc., 1900 Barnwell St., Columbia, S. C.

**THERMISTORS**. 13-page glossy catalog gives definition, manufacturing process, characteristics and application data on 13 types. Many illustrations and diagrams.—Nucleonic Products Co. Inc., 1601 Grande Vista Ave., Los Angeles 23, Calif.

Any or all of these catalogs, bulletins, or periodicals are available to you on request direct to the manufacturers, whose addresses are listed at the end of each item. Use your letter-head—do not use postcards. To facilitate identification, mention the issue and page of RADIO-ELECTRONICS on which the item appears. UNLESS OTHERWISE STATED, ALL ITEMS ARE GRATIS. ALL LITERATURE OFFERS ARE VOID AFTER SIX MONTHS.

## BARGAIN CURRENT INDICATOR

A 150 to 250-ma pilot lamp can be used to effectively adjust horizontal amplifier drive and similar circuits for minimum current. A fuse substitute is made from a piece of dowel and the ends of a blown fuse. The newer twistlock fuses are a bit more difficult to substitute but it is still possible. Drill a hole through the end caps of the fuse for

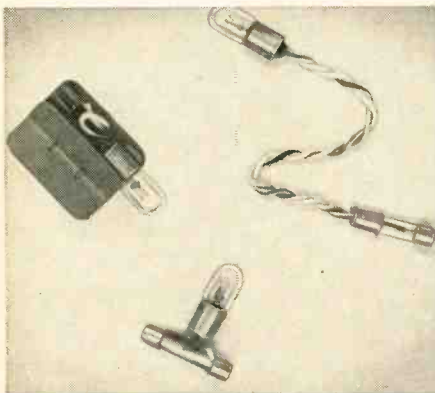

the inner contact wire. The dimmer the lamp, the lower the value of current passing through it.

a. The photo shows: dowel replaces glass fuse body.

b. The pilot lamp is held in one end of the snap-on fuse holder. Jumper makes the connection to the center contact.

c. Top wire is soldered first so heat will not affect insulation of wire through hole that makes contact with bottom contact.—Elmer Carlson

The first issue of the quarterly R·A·E Journal has now been received by more than 10,000 members of the R·A·E Society—the national organization devoted to the interests of radio, audio, and electronic kit-builders. From initial reports, the Journal is a resounding success. Comments from Society members say: "Bravo"—"Something we have really needed"—"It's a must for kit-builders"—"Filled with wonderful, original ideas."

The R·A·E Journal is available *only* to members of the Society. You can't buy a copy anywhere. However, more copies are being mailed out daily. You can have one, too. So read on.

### WHY THE FIRST ISSUE OF THE JOURNAL SCORED A BULL'S EYE

Under the direction of Milton B. Sleeper, one of the radio-audio pioneers and a recognized authority on kit design, the R·A·E Journal is devoted exclusively to the interests of kit-builders (no record reviews or articles on music).

The new issue contains ten articles and departments on kit designs, kit construction, system planning, Society activities, and related subjects. The Journal serves beginners as well as advanced enthusiasts with how-to articles, reports, and comments written in a clear, concise manner, profusely illustrated with drawings and photographs handsomely printed on fine paper.

It is filled with original ideas, plans, and information on interesting things you can do with simple tools and a kitchen table for a workshop.

When the Journal gets into controversial subjects, no holds are barred. Parts of the "Notes and Comments" and "Members' Roundtable" might be labeled "Too Hot to Handle!" Altogether, you will find the R·A·E Society's Journal unique, stimulating, authoritative.

Most valuable of all are the articles on new kits—kits unlike any you have ever seen because they incorporate developments and practices borrowed from precision instruments and military equipment, but in practical form, suited to home construction.

### THE FIRST R·A·E KITS

The first R·A·E kits will be available in August. The overall design, assembly and wiring methods, appearance of the finished instruments, and even the instructions and diagrams are totally unlike any now available. *They are not instruments in kit form that*

were originally designed for factory production-line assembly. R·A·E kits are designed by kit-builders, specifically for kit-builders.

### R·A·E SOCIETY MEMBERS SERVE ON THE ADVANCE-TEST PANELS

Before a new R·A·E kit is released, it will be pre-checked by Society members in this way: Ten prototypes will be given to 10 members, some of whom are beginners, some advanced enthusiasts and professionals. Each will assemble his kit and report on his experiences. In return, he will keep the finished kit, without charge. A new panel will be chosen for each new kit; no member may serve twice. Any Society member may apply to serve on an Advance-Test Panel. No purchase of equipment is necessary.

### YOU ARE INVITED TO JOIN THE R·A·E SOCIETY

Whether you are a beginner or an experienced kit-builder, you are invited to join the R·A·E Society. Details of the Society's activities are published in the Journal. Annual dues of \$1.00 entitle you to all privileges of membership, to receive four issues of the quarterly Journal, and to qualify for service on an Advance-Test Panel.

Use the coupon below or your own stationery. Read the UNCONDITIONAL GUARANTEE in the coupon.

TO GET THE FIRST ISSUE OF THE JOURNAL, RUSH YOUR MEMBERSHIP APPLICATION TODAY!



R·A·E SOCIETY  
(sponsored by R·A·E  
Equipment, Inc.)  
Housatonic Station 4  
Great Barrington, Mass.

Yes, I want to participate in the R·A·E Society's activities. I enclose \$1 as my membership dues for one year. I understand that I will receive a Membership Card, the quarterly Journal issues for one year, and may qualify to serve on the Advance-Test Panel.

Name \_\_\_\_\_  
Street \_\_\_\_\_

City & Zone \_\_\_\_\_ State \_\_\_\_\_

I understand that I am not required to purchase any R·A·E kits to enjoy membership privileges. I am a  Beginner  Experienced kit-builder  Professional

UNCONDITIONAL MONEY-BACK GUARANTEE  
If I am not completely satisfied after I receive and examine my first issue of the Quarterly Journal, my money will be refunded promptly on request. No extra charge outside the USA.

# "ONE DOLLAR" buys

As much as \$15 worth - Everything Brand New and sold to you with a money back guarantee.

**10% OFF & FREE GIFT ON PURCHASE OF \$10 OR OVER (ON DOLLAR BUYS)**

- |   |   |   |   |
|---|---|---|---|
| <input type="checkbox"/> \$15.00 RADIO PARTS "JACKPOT" handy assortment             | <input type="checkbox"/> 100 - ASSORTED 1/2 WATT RESISTORS some in 5%       | <input type="checkbox"/> 15 - ASSORTED ROTARY SWITCHES regular \$15 value   | <input type="checkbox"/> \$15.00 TELEVISION PARTS "JACKPOT" best buy ever         |
| <input type="checkbox"/> 1 - 5" PM SPEAKER alnico #5 magnet                         | <input type="checkbox"/> 70 - ASSORTED 1 WATT RESISTORS some in 5%          | <input type="checkbox"/> 10 - 6' ELECTRIC LINE CORDS with plug  | <input type="checkbox"/> 25 - ASSORTED TV COILS 1.F. video, sound ratio, etc.     |
| <input type="checkbox"/> 1 - 4" PM SPEAKER alnico #5 magnet                         | <input type="checkbox"/> 35 - ASSORTED 2 WATT RESISTORS some in 5%          | <input type="checkbox"/> 4 - 50' SPOOLS HOOK-UP WIRE 4 different colors   | <input type="checkbox"/> 1 - \$10 INDOOR TV ANTENNA hi-gain, 3 section, tiltproof |
| <input type="checkbox"/> 1 - 3" PM SPEAKER alnico #5 magnet                         | <input type="checkbox"/> 40 - ASST. PRECISION RESISTORS in 1 percenters     | <input type="checkbox"/> 25' - INSULATED SHIELDED WIRE #20 braided metal jacket   | <input type="checkbox"/> 5 - TV CHEATER CORDS with both plugs                     |
| <input type="checkbox"/> 1 - 3 1/2" TWEETER SPEAKER for Hi-Fi                       | <input type="checkbox"/> 10 - ASSTED WIREWOUND RESISTORS 5, 10, 20 watt     | <input type="checkbox"/> 32' - TEST PROD WIRE deluxe quality, red or black  | <input type="checkbox"/> 65' - STANDARD ZIP CORD #18 2-conductor brown or Ivory   |
| <input type="checkbox"/> 5 - SETS SPEAKER PLUGS male & female, wired, long leads    | <input type="checkbox"/> 50 - ASSORTED TUBULAR CONDENSERS .001 to .47       | <input type="checkbox"/> 50 - STRIPS ASSORTED SPAGHETTI handy sizes   | <input type="checkbox"/> 65' - MINIATURE ZIP CORD 2 conductor, 101 uses           |
| <input type="checkbox"/> 3 - AUDIO OUTPUT TRANSFORMERS 50L6 type                    | <input type="checkbox"/> 50 - ASST. CERAMIC CONDENSERS some in 5%           | <input type="checkbox"/> 100 - ASSORTED RUBBER GROMMETS best sizes  | <input type="checkbox"/> 100' - TWIN TV LEAD-IN WIRE 300 ohm, heavy duty          |
| <input type="checkbox"/> 2 - AUDIO OUTPUT TRANSFORMERS 50L6 push-pull               | <input type="checkbox"/> 50 - ASST. MICA CONDENSERS some in 5%              | <input type="checkbox"/> 50' - HI-VOLTAGE WIRE for TV, special circuits, etc.   | <input type="checkbox"/> 50' - FLAT 4-CONDUCTOR WIRE many purposes                |
| <input type="checkbox"/> 3 - AUDIO OUTPUT TRANSFORMERS 6K6 or 6V6 type              | <input type="checkbox"/> 35 - ASST. DISC CERAMIC CONDENSERS popular numbers | <input type="checkbox"/> 200' - BUSS WIRE #20 tinned for hookups, special circuits, etc.  | <input type="checkbox"/> 20 - ASSORTED TV KNOBS ESCUTCHEONS, \$20 value           |
| <input type="checkbox"/> 2 - AUDIO OUTPUT TRANSFORMERS 6K6 push-pull                | <input type="checkbox"/> 35 - DISC CERAMIC CONDENSERS 5000 mmf              | <input type="checkbox"/> 200' - HOOK-UP WIRE any color of your choice   | <input type="checkbox"/> 15 - ASSORTED STANDARD TUNER VHF STRIPS                  |
| <input type="checkbox"/> 3 - AUDIO OUTPUT TRANSFORMERS 3Q4, 3Q5, 3S4                | <input type="checkbox"/> 25 - ASSORTED MICA TRIMMER CONDENSERS              | <input type="checkbox"/> 250 - ASST. SOLDERING LUGS best types and sizes  | <input type="checkbox"/> 6 - ASSORTED STANDARD TUNER UHF STRIPS                   |
| <input type="checkbox"/> 3 - I.F. COIL TRANSFORMERS 456kc, most popular type        | <input type="checkbox"/> 50 - 100K 1/2 WATT RESISTORS 10%                   | <input type="checkbox"/> 1 - LB SPOOL ROSIN-CORE SOLDER 40/60   | <input type="checkbox"/> 1 - 70° FLYBACK TRANSFORMER incl. Schematic Diagram      |
| <input type="checkbox"/> 3 - I.F. COIL TRANSFORMERS 456kc transformer type 3/4x3/4" | <input type="checkbox"/> 50 - 220K 1/2 WATT RESISTORS 10%                   | <input type="checkbox"/> 600 - ASST. HARDWARE KIT screws, nuts, washers, rivets, etc.   | <input type="checkbox"/> 1 - 90° FLYBACK TRANSFORMER incl. Schematic Diagram      |
| <input type="checkbox"/> 2 - G.E. #RTL-1431.F. COIL TRANSFORMERS 456kc w/flange     | <input type="checkbox"/> 50 - 470K 1/2 WATT RESISTORS 10%                   | <input type="checkbox"/> 100 - ASST. RUBBER FEET FOR CABINETS best sizes  | <input type="checkbox"/> 1 - TV VERTICAL OUTPUT TRANSFORMER 10 to 1 ratio         |
| <input type="checkbox"/> 3 - I.F. COIL TRANSFORMERS 10.7mc for FM                   | <input type="checkbox"/> 50 - ASSORTED FUSES popular sizes 3AG, 4AG, etc.   | <input type="checkbox"/> 200 - ASST. SELF TAPPING SCREWS #6, #8, etc.   | <input type="checkbox"/> 1 - TV VERTICAL OUTPUT TRANSFORMER 16 to 1 ratio         |
| <input type="checkbox"/> 3 - I.F. COIL TRANSFORMERS 262kc for Auto Radios           | <input type="checkbox"/> 20 - TUBULAR CONDENSERS .001-600v                  | <input type="checkbox"/> 150 - ASST. 6/32 SCREWS & 150 - 6/32 HEX NUTS  | <input type="checkbox"/> 1 - VERTICAL BLOCKING TRANSFORMER standard type          |
| <input type="checkbox"/> 4 - OVAL LOOP ANTENNAS assorted popular sizes              | <input type="checkbox"/> 20 - TUBULAR CONDENSERS .005-600v                  | <input type="checkbox"/> 150 - ASST. 8/32 SCREWS & 150 - 8/32 HEX NUTS  | <input type="checkbox"/> 2 - RATIO DETECTOR COILS 4.5mc or 10.7mc                 |
| <input type="checkbox"/> 3 - LOOPSTICK ANTENNAS hi-gain, ferrite, adjustable        | <input type="checkbox"/> 15 - TUBULAR CONDENSERS .047-800v                  | <input type="checkbox"/> 150 - 6/32 HEX NUTS & 150 - 8/32 HEX NUTS  | <input type="checkbox"/> 2 - TV SOUND I. F. COILS 4.5mc or 21.25 mc               |
| <input type="checkbox"/> 3 - VARIABLE CONDENSERS superhet 420/162 mfd               | <input type="checkbox"/> 15 - TUBULAR CONDENSERS .47-400v                   | <input type="checkbox"/> 8 - ASST. LUCITE CASES hinged cover, handy for parts   | <input type="checkbox"/> 2-SOUND DISCRIMINATOR COILS 4.5mc or 10.7mc              |
| <input type="checkbox"/> 3 - ASST. SIZES RADIO CHASSIS PANS drilled & plated        | <input type="checkbox"/> 20 - TUBULAR CONDENSERS .61-600v                   | <input type="checkbox"/> 4 - TOGGLE SWITCHES SPST, SPDT, DPST, DPDT   | <input type="checkbox"/> 25 - ASSORTED TV PEAKING COILS all popular types         |
| <input type="checkbox"/> 10 - RADIO OSCILLATOR COILS standard 456kc                 | <input type="checkbox"/> 15 - TUBULAR CONDENSERS .1-600v                    | <input type="checkbox"/> 6 - ASST. SLIDE SWITCHES SPST, DPDT, etc.  | <input type="checkbox"/> 4 - ASST. TV ION TRAPS for all type TV Receivers         |
| <input type="checkbox"/> 3 - 1/2 MEG VOLUME CONTROLS with switch, 3/8" shaft        | <input type="checkbox"/> 15 - TUBULAR CONDENSERS .25-600v                   | <input type="checkbox"/> 6 - ROTARY SWITCHES 2 positions, DPDT  | <input type="checkbox"/> 4 - TV CENTERING RINGS fits on back of deflection yoke   |
| <input type="checkbox"/> 5 - 1/2 MEG VOLUME CONTROLS less switch                    | <input type="checkbox"/> 10 - HI-VOLTAGE CONDENSERS .007-1800v              | <input type="checkbox"/> 35 - MICA CONDENSERS 20 - 5 mmf and 15 - 25 mmf  | <input type="checkbox"/> 4 - TV CENTERING RINGS fits on neck of picture tube      |
| <input type="checkbox"/> 5 - 50K VOLUME CONTROLS less switch                        | <input type="checkbox"/> 10 - ASST. RADIO ELECTROLYTIC CONDENSERS           | <input type="checkbox"/> 35 - MICA CONDENSERS 20 - 100 mmf and 15 - 250 mmf   | <input type="checkbox"/> 5 - TV PICTURE TUBE SOCKETS wired with 20" lead          |
| <input type="checkbox"/> 5 - ASST. 4 WATT WIREWOUND CONTROLS                        | <input type="checkbox"/> 5 - ASST. TV ELECTROLYTIC CONDENSERS               | <input type="checkbox"/> 35 - MICA CONDENSERS 20 - 470mmf and 15 - 680mmf   | <input type="checkbox"/> 5 - TV HI-VOLT ANODE LEADS 20" length                    |
| <input type="checkbox"/> 10 - ASSORTED VOLUME CONTROLS less switch                  | <input type="checkbox"/> 4 - ELECTROLYTIC CONDENSERS 40-150v                | <input type="checkbox"/> 35 - MICA CONDENSERS 20 - 820mmf & 15 - 1000mmf  | <input type="checkbox"/> 12 - ASSORTED GRID CAPS for 1B3, 1X2, 6BG6, 6BQ6, etc.   |
| <input type="checkbox"/> 5 - ASSORTED VOLUME CONTROLS with switch                   | <input type="checkbox"/> 2 - ELECTROLYTIC CONDENSERS 50/50-150v             | <input type="checkbox"/> 35 - MICA CONDENSERS 20 - 2000mmf & 15 - 2500 mmf  | <input type="checkbox"/> 3 - TV CARTWHEEL CONDENSERS 20 kv - 500 mmf              |
| <input type="checkbox"/> 100 - VOLUME CONTROL HEX NUTS fits 3/8" bushing            | <input type="checkbox"/> 5 - ELECTROLYTIC CONDENSERS 25-50v                 | <input type="checkbox"/> 35 - MICA CONDENSERS 20 - 3300mmf & 15 - 4700mmf   | <input type="checkbox"/> 2 - TV CARTWHEEL CONDENSERS 30 kv - 500 mmf              |
| <input type="checkbox"/> 10 - SURE-GRIP ALLIGATOR CLIPS 2" plated                   | <input type="checkbox"/> 4 - ELECTROLYTIC CONDENSERS 10-450v                | <input type="checkbox"/> 35 - CERAMIC CONDENSERS 20 - 5 mmf and 15 - 10 mmf   | <input type="checkbox"/> 3 - HY RECTIFIER SOCKETS for 1B3 Tube, mounted           |
| <input type="checkbox"/> 1 - GOLD GRILLE CLOTH 14"x14" or 12"x18"                   | <input type="checkbox"/> 2 - ELECTROLYTIC CONDENSERS 40/40-450v             | <input type="checkbox"/> 35 - CERAMIC CONDENSERS 20 - 25 mmf and 15 - 47 mmf  | <input type="checkbox"/> 1 - TV FOCALIZER adjustable for any ohmage               |
| <input type="checkbox"/> 10 - SETS PHONO PLUGS & PIN-JACKS RCA type                 | <input type="checkbox"/> 4 - ELECTROLYTIC CONDENSERS 100-50v                | <input type="checkbox"/> 35 - CERAMIC CONDENSERS 20 - 36 mmf and 15 - 82 mmf  | <input type="checkbox"/> 1 - SILICON RECTIFIER 750ma, 500PIV                      |
| <input type="checkbox"/> 20 - ASST. PILOT LIGHTS #44, 46, 47, 51, etc.              | <input type="checkbox"/> 4 - ELECTROLYTIC CONDENSERS 80-400v                | <input type="checkbox"/> 35 - CERAMIC CONDENSERS 20 - 100mmf & 15 - 150mmf  | <input type="checkbox"/> 2 - SILICON RECTIFIERS 500ma, 400PIV                     |
| <input type="checkbox"/> 10 - PILOT LIGHT SOCKETS bayonet type, wired               | <input type="checkbox"/> 30 - FP ELECTROLYTIC COND. MOUNTING WAFERS         | <input type="checkbox"/> 35 - CERAMIC CONDENSERS 20 - 250mmf & 15 - 470mmf  | <input type="checkbox"/> 3 - SILICON RECTIFIERS 350ma, 260 PIV                    |
| <input type="checkbox"/> 50 - ASSORTED TERMINAL STRIPS 1, 2, 3, 4 lugs              | <input type="checkbox"/> 5 - DIODE CRYSTALS 2-IN-1 1-IN34, 1-IN60, 1-IN64   | <input type="checkbox"/> 5 - ASSORTED TUBES Radio, TV, Industrial   | <input type="checkbox"/> 3 - TV ALIGNMENT TOOLS Assortment #1                     |
| <input type="checkbox"/> 100' - FINEST NYLON DIAL CORD best size, .028 gauge        | <input type="checkbox"/> 5 - DIODE CRYSTALS 2-IN34 1-IN60, 1-IN69, 1-IN82   | <input type="checkbox"/> 4 - TUNGSOIL 1U4 TUBES also serves as 1T4  | <input type="checkbox"/> 3 - TV ALIGNMENT TOOLS Assortment #2                     |
| <input type="checkbox"/> 50 - ASST. RADIO KNOBS screw and push-on types             | <input type="checkbox"/> 3 - SELENIUM RECTIFIERS 2 - 65ma and 1 - 75ma      | <input type="checkbox"/> 3 - SYLVANIA 35W4 TUBES factory cartoned   | <input type="checkbox"/> 3 - TV ALIGNMENT TOOLS Assortment #3                     |
| <input type="checkbox"/> 100 - ASSORTED KNOB SET-SCREWS best sizes                  | <input type="checkbox"/> 2 - SELENIUM RECTIFIERS 1 - 100 ma and 1 - 250 ma  | <input type="checkbox"/> STANDARD BRAND TUBES 024, 1B3, 1X2, 5U4, 5Y3, 6AC7, 6AU6, 6AX4, 6CB6, 6CG7, 6J6, 6K6, 6SN7, 6U8, 6X6, 12AT7, 12AU7, 12AX4, 60L6. Each Tube | <input type="checkbox"/> 3 - TV ALIGNMENT TOOLS Assortment #4                     |
| <input type="checkbox"/> 25 - ASSORTED RADIO DIAL POINTERS popular types            | <input type="checkbox"/> 2 - SELENIUM RECTIFIERS 2 - 1N2                    |   | <input type="checkbox"/> 3 - TV ALIGNMENT TOOLS Assortment #5                     |
| <input type="checkbox"/> 25 - ASSORTED CLOCK RADIO KNOBS in colors                  | <input type="checkbox"/> 2 - SELENIUM RECTIFIERS 1 - 65ma and 1 - 450ma     |   |   |
| <input type="checkbox"/> 50 - ASSORTED SOCKETS all type 7 pin, 8 pin, 9 pin         | <input type="checkbox"/> 20 - ASST. TUBE SHIELDS for 7 pin and 9 pin Tubes  |   |   |
| <input type="checkbox"/> 25 - ASSORTED PRINTED CIRCUIT SOCKETS best types           | <input type="checkbox"/> 100 - ASSORTED TUBE CARTONS                        |   |   |
| <input type="checkbox"/> 20 - INSTRUMENT POINTER KNOBS popular screw type           | <input type="checkbox"/> 5 - 9 V RADIO BATTERIES similar to Eveready #218   |   |   |

**HANDY WAY TO ORDER** - Simply pencil mark items wanted (X in square is sufficient), enclose with money order or check. You will receive a new copy of these offers for re-orders.

**ON SMALL ORDERS** - Include stamps for postage, excess refunded. **LARGER ORDERS** shipped express charges collect.

**BROOKS RADIO & TV CORP., 84 Vesey St., Dept. A, New York 7, N.Y.** TELEPHONE CO. 7-2359



# NEW TUBES and SEMI-CONDUCTORS

EVER SEE A QUADRUPLE DIODE IN A 9-PIN envelope? You will in just a few moments. It will be followed by a 10.7-mc FM i.f. transistor, a compactron mobile communications tube, a couple of i.f. pentodes and a forced-air cooled metal-ceramic communications tube.

## 6JU8

A quadruple diode in a 9-pin miniature envelope. It is intended for use

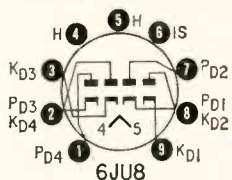

in phase-detector and noise-immune color-killer circuits of color TV receivers, and in FM stereo multiplex equipment.

Maximum ratings of the RCA 6JU8 are:

PIV <sub>p</sub>	300
I <sub>p</sub> (peak ma)	54
I <sub>out</sub> (dc ma)	9
V <sub>htr-cath</sub> (peak)	
(htr neg with respect to cath)	300
(htr pos with respect to cath)	300

## 2N1747

A p-n-p germanium MADT unit designed for 10.7-mc FM i.f. and limiter applications and for AM/FM i.f. stages

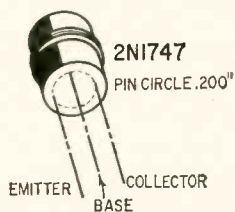

which are only used for FM i.f. signals. It is intended for use in 6-volt auto and 6 to 9-volt portable radios.

Absolute maximum ratings of the Philco 2N1747 are:

V <sub>CB</sub>	20
V <sub>CEB</sub>	20
V <sub>EB</sub>	0.5
I <sub>C</sub> (ma)	50
P <sub>total</sub> (mw)	60

## 7984

This a compactron version of the

# SAVE CUSTOMERS MAKE MONEY

THE INDUSTRY'S STANDARD

Most Widely Used Today by Professional Servicemen

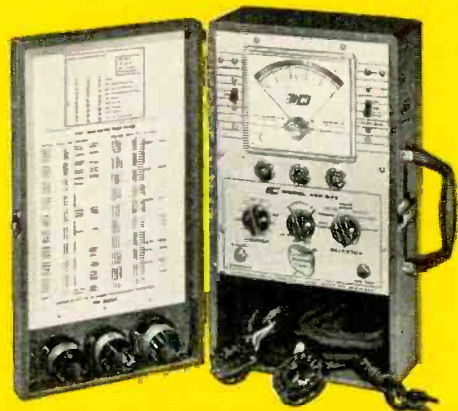

## FAMOUS DELUXE B&K CRT 440



For Black & White and Color

"Most valuable and useful" . . . "Wouldn't be without it" . . . "Pays for itself over and over again" . . . servicemen say. Quickly checks and corrects television picture tube troubles in a few minutes right in the home without removing tube from set. Gives new life to weak or inoperative tubes. Checks for leakage, shorts, open circuits and emission. Removes inter-element shorts and leakage. Repairs open circuits and low emission. Restores emission and brightness. Life Test checks gas content and predicts remaining useful life of picture tube. Makes new tube sales easier. Completely self-contained. Rich leatherette-covered carry-case. Net, \$74.95

- TESTS AND REJUVENATES all picture tubes at correct filament voltage from 1 to 12 volts.
- TESTS AND REJUVENATES 110° tubes and the new 19" and 23" tubes
- TESTS AND REJUVENATES color picture tubes. Checks each gun of color tube separately

### UP-DATE YOUR B&K CRT WITH THESE ACCESSORIES

Subscribe to New Picture Tube Information Service

- Model C40 Adapter. For use with previous Models 400 and 350 CRT's—to test and rejuvenate TV color picture tubes and 6.3 volt 110° picture tubes. Net, \$9.95
- Model CR48 Adapter. For use with previous Models 400 and 350 CRT's—to test and rejuvenate 110° picture tubes with 2.34, 2.68, and 8.4 volt filaments. Net, \$4.95

See Your B&K Distributor, or Write for Catalog AP20-E

**B & K MANUFACTURING CO.**  
1801 W. BELLE PLAINE AVE • CHICAGO 13, ILL.  
Canada: Atlas Radio Corp., 50 Wingold, Toronto 19, Ont.  
Export: Empire Exporters, 277 Broadway, New York 7, U.S.A.



### WANT TO SELL?—buy? trade? find out?

RADIO-ELECTRONICS Classified Ads can bring you results. Only 50¢ a word—minimum 10 words. Send copy with check or money order to:  
RADIO-ELECTRONICS, 154 West 14th Street, New York 11, N. Y.

## fix ELECTRIC APPLIANCES \$3 TO \$5 AN HOUR

FREE BOOK tells about it. Our complete, easy profitable spare-time or full-time business that pays \$3-\$5 hour—right at home! 400 MILLION Appliances now in use. People need them fixed. YOU make good money doing

it. Our complete, easy course trains you for top earnings. At no extra charge you get time-saving Appliance Tester. Get FREE Book, FREE Sample Lesson! Mail coupon NOW.

**NATIONAL RADIO INSTITUTE, Appliance Div.**  
Dept. FF2, Washington 16, D.C.

Send FREE Book, FREE Appliance Repair Course Lesson.

Name.....

Address.....

City..... Zone..... State.....

## CONVERT TO COLOR TV

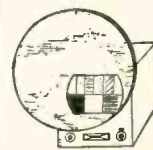

**COLORDAPTOR**—A simple 10-tube circuit and rotating color wheel converts any size B & W TV to receive compatible color.

**COLORDAPTOR**—Easily attached to any TV set, does not affect normal operation, often built from parts experimenters have on hand. **BRILLIANT COLOR!**

Complete booklet—gives theory of operation, all construction details, schematic, and sample color filters. \$195

Essential Parts Kit—Includes all special parts—coils, delay line, crystal, color filters. Add \$1.00 for sets over 16". \$19.95

**COLORDAPTOR** 1798 Santa Cruz, Menlo Park, Calif.

Discover the exciting world of communication electronics with these

**NEW**  
**Basic Communication Kits**

Here are Kits anyone can use to acquire knowledge of communication electronics.

**Starter Kit** contains all parts necessary to experiment with communications circuitry and construct two control boxes with headphones and microphones, two speech amplifiers and one transistorized voltmeter. Only \$34.95 (including comprehensive manual).

**AM Radio Add-On Kit** lets you assemble an AM transmitter and an AM receiver for use with Starter Kit (above) to experiment with radio frequency modulation, detection and two way wireless communications. Only \$15.00.

**Modulated Light Beam Add-On Kit** consists of a transmitter and receiver for use with the Starter Kit to expand your communications experiments using light as the sound transmitting medium. Only \$15.00.

**THESE NEW KITS** provide an introduction to communication techniques, electronic components and electronic communication systems.

**FULLY GUARANTEED** against defects in manufacture. In addition, these Kits carry a 10-day unconditional money-back guarantee. All prices F.O.B., Watertown, Mass.

**EASY-TO-UNDERSTAND MANUAL** accompanies each Starter Kit . . . gives a complete description of electronic components and their functions in clear, non-technical language. Easy-to-follow, step-by-step instructions and experiments. No prior knowledge of electronics is necessary.

SEND FOR DESCRIPTIVE LITERATURE — TODAY!

Scientific Development Corporation  
Dept. RE-6  
372 Main Street  
Watertown, Massachusetts

Please send literature on Basic Communication Kits.

Name.....  
Street.....  
City.....Zone.....State.....

**YOU'RE SAFE . . . .**

when you buy receiving tubes by mail from Radio-Electronics advertisers. For over five years, we have insisted that advertisers indicate that their tubes are new and unused or seconds or rejects if that's the case. This policy has cost us advertising but it has protected you.

popular 6146. In its new shape the tube

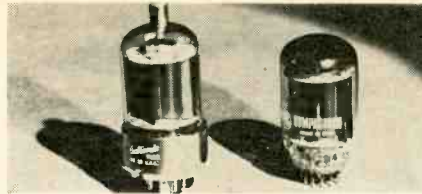

delivers 46 watts at 175 mc, 11 more than the earlier version.

The G-E 7984 has a 13.5-volt 580-ma heater. Maximum ratings in intermittent mobile rf service, class-C telegraphy and FM telephony are:

$V_P$	750
$V_{G2}$	250
$V_{G1}$	—150
$I_P$ (ma)	180
$I_{G1}$ (ma)	4
$P_P$ (watts)	35

Typical operation as a 175-mc amplifier:

$V_P$	450
$V_{G2}$	125
$V_{G1}$	—60
$R_{G1}$ (kohms)	25
$I_P$ (ma)	180
$I_{G2}$ (ma)	12
$I_{G1}$ (ma)	2.5
Driving power (watts)	2
Power output (watts)	46

**6HR6, 19HR6**

These two 7-pin miniature pentodes are designed for use as i.f. amplifiers in FM, AM and FM/AM receivers. They are identical except for their heater ratings. The 6HR6 has a 6.3-

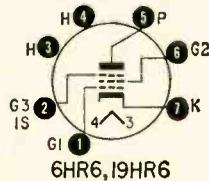

volt 450-ma heater while the 19HR6 has an 18.9-volt 150-ma heater.

Maximum ratings of the RCA HR6 in class-A1 amplifier service are:

$V_P$ (supply)	200
$G3$ connected to cathode at socket	
$V_{G2}$ (supply)	115
$V_{G1}$ (supply)	0
$R_K$ (ohms)	68
$R_P$ (approx kohms)	500
gm ( $\mu$ mhos)	8,500
$I_P$ (ma)	13.2
$I_{G2}$ (ma)	4.3

**8177**

This uhf tetrode is a metal-ceramic, coaxial, forced-air-cooled unit for frequencies up to 1,000 mc. The tube is especially designed for use as a power amplifier and frequency multiplier in TV transmitters, vhf-uhf communications, and tropospheric scatter equipment.

With a plate current capability of 0.95 ampere, the Amperex 8177 can provide a power output of 2,070 watts at 600 mc and 1,500 watts at 900 mc in class C telephony operation. The tube has a helical thoriated tungsten filamentary cathode for extra long life in critical applications.

END

new books for the technician experimenter hobbyist who likes to **GET THINGS DONE**

**HINTS & KINKS FOR RADIO, TV & AUDIO**  
Edited by Martin Clifford  
Gernsback Library Book No. 103  
128 pages \$2.35

A unique and helpful selection of tips on how to use all sorts of gadgets and gimmicks like paper clips, drinking straws, grommets, corkscrews, tape and dozens of other everyday items as helps and timesavers in your servicing or experimenting be it TV, Radio, Audio—or just plain electronic tinkering. Editor Clifford selected the best from thousands of hints and kinks sent in to Radio-Electronics magazine by ingenious readers. This book is really priceless. Any one of these 280 suggestions may be worth hundreds of dollars to you in time and effort saved or in work more easily done.

**JUST A FEW OF THE COLLECTION OF 280 HINTS & KINKS**

- Test prods. • Test lead storage • Fuse puller • Sticky yokes • Reduce nuisance calls • Toothpaste-tube knob • Boost fringe reception • Servicing aids • Transistor lifesaver • Kit-building kink • Audio test rig • Soldering tip • Gun carries own sander • Novelty blinker • Spaghetti for miniature circuits • Tube tapper and wire pusher • Wing nut driver • Plus 263 more practical shortcuts, timesavers and bench helpers.

**RADIO-CONTROL HANDBOOK**  
By Howard G. McEntee  
Revised and greatly enlarged edition  
Gernsback Library Book No. 93  
304 pages \$4.95

Enough R/C material to fill two books. The book bulges with practical information with emphasis on how to do it, not why it happens. The original edition sold out completely after eight printings. This big second edition is completely updated — obsolescent material has been dropped, new developments added. Offers scores of new ideas, circuits and construction details on receivers, transmitters, servos, pulsers, escapements, controls, relays plus inside tips on installation, adjustments, testing and building of complete systems.

**ORDER TODAY FROM YOUR DISTRIBUTOR**

or use this coupon  
Gernsback Library, Inc. 12  
154 West 14th St.  
New York 11, N. Y.

Please send me the books indicated postpaid  
My remittance of \$\_\_\_\_\_ is enclosed

\_\_\_\_\_ please list books selected by number

NAME: \_\_\_\_\_  
STREET: \_\_\_\_\_  
CITY: \_\_\_\_\_ ZONE: \_\_\_\_\_ STATE: \_\_\_\_\_

# new PATENTS

## POWER SUPPLY FOR DIRECT-COUPLED AMPLIFIER

Patent No. 2,970,278

John H. Reaves, McLean, Va. (Assigned to USA as represented by Secretary of Commerce)

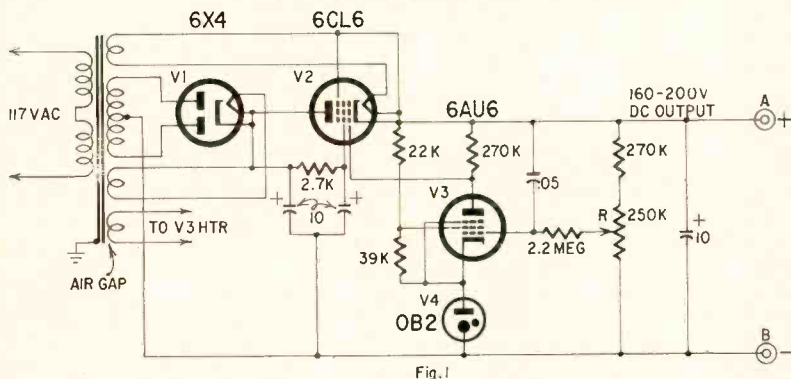

Fig. 1

In this type of amplifier, the plate of one stage is connected to the grid of the next. Since a plate requires a high positive voltage, while a grid must be negative, a suitable power supply must not couple the stages. However, the capacitance (to ground) of a conventional supply may be as high as 700  $\mu\text{f}$ .

This power supply is specially designed for low capacitance, near 18  $\mu\text{f}$ , to minimize coupling. It is voltage-regulated to eliminate filter chokes, which introduce high capacitance (Fig. 1). It delivers 200 volts without load, 199 volts at 20-ma drain.

The secondary of the transformer is kept well away from the primary by winding it on another leg of the core, to reduce capacitance (Fig. 2). Chassis and panel are made of insulating Plexiglass.

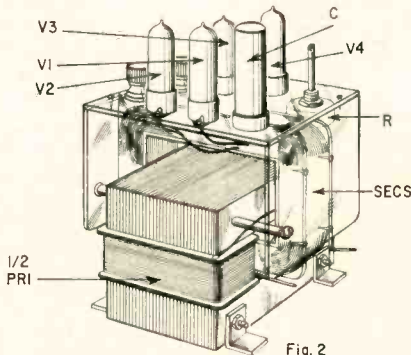

Fig. 2

## PRECISE TIMER

Patent No. 2,976,487

Esra Cohen, Brooklyn, N.Y. (Assigned to Bell Telephone Labs, Inc.)

In R-C timers, a capacitor charges to a critical voltage, at which instant a relay is energized. If the supply voltage is unregulated, the timing interval cannot be controlled precisely. This inventor discloses an ingenious solution to the problem.

Two power supplies are used, one positive, the other negative, relative to ground. By Ohm's law, the voltage at point G is

$$A - (A + B) \left( \frac{R_1}{R_1 + R_2} \right)$$

When S is closed, the voltage on capacitor C is -B volts. When S is opened, the capacitor begins to charge to A volts. From the usual formula for a charging capacitor, the voltage at point H is found to be

$$A - (A + B)e^{-T/RC}$$

Choosing  $T = RC$ , it is evident that the above equations are identical when

$$\frac{1}{e} = \frac{1}{2.7} = \frac{R_1}{R_1 + R_2}$$

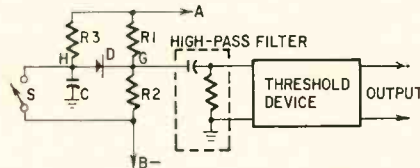

When R1 and R2 are chosen in accordance with the previous equation, the voltages at points G and H will be equal (and D will conduct after a timing interval of  $T = RC$  seconds). There will be an abrupt voltage change from whatever value G had to the value present at H, and this pulse will be passed through a filter. It will excite a threshold device, which may be a multivibrator. Thus the exact instant of conduction by D can control some output device.

Note that the timing instant does not depend upon either A or -B, the supply voltages.

## TV REMOTE CONTROL

Patent No. 2,997,535

Sheldon T. Brady, N. Hollywood, and Brian E. Hooper, Sherman Oaks, Calif. (Assigned to Packard-Bell Electronics Corp., Los Angeles, Calif.)

This control is very compact since it contains no power source of its own. Instead it receives a 100-kc signal from the nearby TV receiver. When S1 is closed (see schematic) the signal is rectified and used to bias V, a harmonic generator. Output is 300 kc if S2 is closed, 400 kc if S3 is closed. Additional harmonics and switches may be added if desired.

The selected harmonic is radiated back to the TV set, which amplifies it and uses it to control a relay. Each harmonic controls a different function, such as switching on and off, setting volume, tuning, etc.

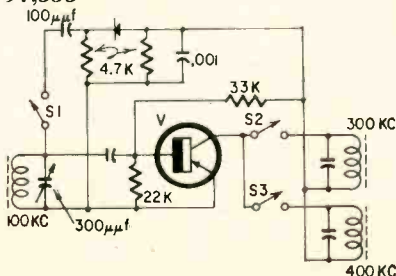

# Win with EMC



By far the BEST VALUE obtainable in either wired or kit form... compare and you'll agree "THE BEST BUY IS EMC."

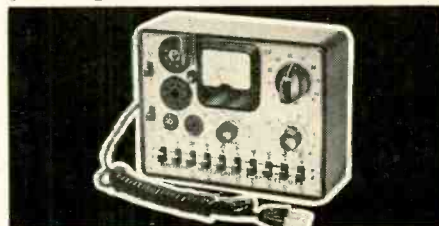

EMC Model - 211 Tube Tester - The smallest, lowest priced, domestic made tube tester on the market. It is completely flexible and obsolescent proof. It checks each section of multi-purpose tubes separately, checks all octal, loctal, 9 prong and miniature tubes for shorts, leakages, opens, intermittents as well as for quality. Quality is indicated directly on a two color meter dial using the standard emission test. Comes complete with instructions and tube charts in ring bound manual. Size 6 3/4" x 5 1/4" x 2 3/4" deep. Shipping weight: 3 lbs. Wired ..... \$22.90 Kit ..... \$14.90 CR Picture Tube Adapter ..... \$ 4.50

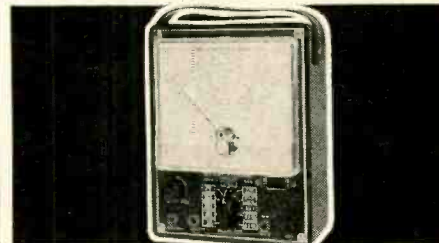

EMC Model 109 - Voltmeter - Features 20,000 OHMS volts DC sensitivity and 10,000 OHMS per volt AC sensitivity. Uses a 4 1/2, 40 microampere meter, with 3 AC current ranges, and 3 resistance ranges to 20 megohms. 5 DC and AC voltage ranges to 3000 volts and 3 DC current ranges; also 5 DB range. Model 109 - With carrying strap, Weight 2 lbs. 5 oz.; Size: 5 1/4" x 6 3/4" x 2 7/8" ..... \$26.95 Model 109K - Kit Form ..... 19.25 Model HV - 30,000 Volt Probe for Model 109 ..... 7.95



EMC Model 107A - Peak to Peak Vacuum Tube Volt-Ohm Capacity Meter - 6" meter cannot burn out - entirely electronic. Measures peak to peak AC voltages to 2800 volts in 6 ranges. Measures capacity in 6 ranges from 50 mmfd to 5000 mfd. Measures resistance in 6 ranges from .2 ohm to 1000 megs. Measures DC volts to 1000 volts in 6 ranges. Input resistance to 16.5 megs. Wired ..... \$51.40 Kit ..... \$36.50

Yes, tell me more, send me FREE a detailed catalog of the Complete EMC Line. Sent. RE-662

NAME .....  
STREET .....  
CITY ..... STATE .....

**EMC** Electronic Measurements Corp.  
625 B'way, New York 12, N. Y.  
Ex. Dept., Pan-Mar Corp., 1270 B'way, New York 1, N. Y.

## A "brass-tacks" guide to TIME-SAVING TEST PROCEDURES!

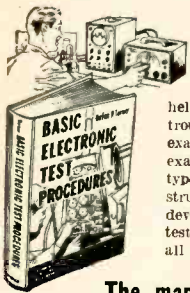

**BASIC ELECTRONIC TEST PROCEDURES** is a big new 316-page manual with the kind of "brass tacks" training that helps you locate TV, AM and FM troubles in a jiffy. Teaches you exactly what instruments to use and exactly where and how to use each type. Tells how to substitute one instrument for another and how to develop time-saving, money-making test methods all along the line in all types of service jobs.

### The manual that helps you CUT TEST TIME IN HALF!

Here are some of the subjects it covers: Current Checks; making measurements of Power, Capacitance, Inductance, Resistance, AF, RF, Phase, Distortion & Modulation; Checking Sensitivity, RF Gain, Fidelity, AVC Voltage, Operating Voltages, etc. Includes handy VISUAL ALIGNMENT TECHNIQUES. Even covers transmitter and industrial electronic test procedures. 190 how-to-do-it pictures and dozens of step-by-step troubleshooting procedure charts make things doubly easy. Price only \$8.50. Money-back guarantee.

### PRACTICE 10 DAYS FREE

Department RE-62  
HOLT, RINEHART & WINSTON, INC. 623900  
P. O. Box 2334, Grand Central Station  
New York 17, New York

Send **BASIC ELECTRONIC TEST PROCEDURES** Manual for 10-day free examination. If I like book, I will then send \$8.50 (plus postage) in full payment. Otherwise I will return manual and owe you nothing. (SAVE! Send \$8.50 with order and we pay postage. Same 10-day return privilege with money refunded promptly.) (=768933)

Name.....

Address.....

City, Zone, State.....

OUTSIDE U.S.A. \$9.00 cash with order. (Above offer expires February 28, 1963)



NEW INGENIOUS tool that takes the hard work out of making component connections. MAKES quick, neat connections in difficult places. PC chassis removal unnecessary in most instances. Easily connect to very short leads on capacitors, resistors, transformers, coils, etc. Eliminates bad solder connections, resin joints, short circuits, broken socket lugs, and damaged PC boards.

A TWIRL-CON tool will bring a bigger return on your investment than any service aid or tool you can buy.

4 sizes: Junior #1, #2, #3. Fits from 22 ga. to 14 ga. wire. #1 and #2 most used sizes. Make more profitable use of your time. Put a TWIRL-CON to work for you TODAY.

\$2.00 ea. Postpaid. Satisfaction Guaranteed. Order from your local Dist. If not available, order from TWIRL-CON TOOLS, 1101 N. East St., EDNA, TEXAS.



Pat. Pend.

# TECHNICIANS' NEWS

## PIONEER TECHNICIANS INCORPORATE

An association intended to unite old-time television-electronic technicians has been organized by a group of six former RCA-NBC television technicians who were actively connected with the first transmissions of modern television 25 years ago. The purpose of the new corporation, according to its charter, is to secure the respect of the public for television-electronic technicians, to increase confidence, and to provide for the development, activities, guidance and general welfare of electronic technicians.

Membership in four grades is planned: The senior group will consist of technicians who were active in the field before 1941; the second group of those who were technicians during the war years and before 1946, the year television effectively reached the public; a general group—those who have been technicians for ten years or more, and an associate member group for those younger TV and electronic technicians not falling in the other groups. Honorary membership may be an elected grade as determined by an awards committee.

An organization meeting has been held, and it is expected that a call for membership will be issued after another charter member meeting, scheduled for early summer, to adopt the constitution and bylaws now being written. Meanwhile, those interested in the new organization may communicate with Mr. W. Hollander Bohlke, Secretary, 39 Treaty Elm Lane, Haddonfield, N. J.

## RTSA-MUNCIE JOINS IESA

Indianapolis, Ind.—The Radio-Television Service Association of Muncie has joined the Indiana Electronic Service Association. Leonard Hickey, president of the group, will be the IESA director from Muncie.

## DOINGS IN INDIANA

Lapel—Installation of new officers was the business of a steak-dinner-meeting held at Passwater's Restaurant. IESA Chairman LaMar Zimmerman, Jr. installed the officers.

President of the group is Don Claus; vice president, James W. Baker; secretary, Gerald Whitesel; treasurer, Harold Scott; and sergeant-at-arms is Earl Jarrett.

Indianapolis—A "Beans and Steak" dinner concluded the membership drive of the Indianapolis Television Technicians Association Inc. Two teams were set up in the membership drive. The team that brought in the

most new members got the steak, the losers got the beans.

## SERVICE CHARGES A PROBLEM

Philadelphia, Pa.—How much to charge a customer seems to be one of the biggest problems the television service technician has to face, according to the February-March issue of Philco's *Servicemen's Bulletin*. The article states "Caught between the rising cost of doing business and squeeze of competition, shop owners today appear unsure of how valuable their services are."

To back up this statement Philco showed that rates vary over a very wide range—from a low of \$2 to as much as \$12 an hour. The average minimum charge turned out to be about \$4.70.

To help clear up the confusion Philco offers this formula to determine what a service shop should charge:

1. Add up all costs for the entire year other than the technician's salary. Divide these costs by the number of full-time technicians, including yourself, who were employed at any one time during the year.

2. Add up all technicians salaries and divide by the number of men to get average salary.

3. Determine the average number of hours per technician per week normally spent on calls. Multiply by 52 weeks. Do not include time spent in picking up parts, making reports or performing administrative duties, but do include overtime and bench work time.

4. Divide the number of hours per year of productive work (step 3) into the sum of steps 1 and 2. The answer is your cost per hour per technician and the basis of your hourly service rate.

5. To arrive at your minimum rate, multiply the cost per hour (step 4) by eight to get your average cost per working day.

6. From your records find the average number of calls per day per technician by adding up all the calls completed in a period, divide by the number of working days in the period and divide again by the number of technicians making the calls.

7. Divide this figure (step 6) into the cost per working day (step 5) to get average cost per service call. This is the basis of minimum service call charges. Obviously, some figure must be added to this basic charge if you are to show a profit.

## TRI-STATE NEWS

Wilmington, Del.—A series of articles are being run in the *News Journal* by the Television Service Dealers Association of Delaware to help promote better customer relations. Members of the group are preparing stories explaining the charges, problems, etc. of the service technician repairing his customer's set.

Camden, N. J.—What's new in the Motorola line was presented to members of the Allied Electronic Technicians Association Inc. of N. J. at a

meeting co-sponsored by Philadelphia Distributors and Motorola. Schematics of the new line of receivers were handed out after the meeting.

*Glenholden, Pa.*—A committee was set up to look into the aspects of helping members who need assistance because of illness, death in the family, etc. The Television Service Dealers Association of Delaware County, Inc. appointed Jim Carver chairman of the committee to be assisted by John Matthey and Charlie Phillips.

### ACTIVITY IN WISCONSIN

*Green Bay*—New officers were officially installed at the annual banquet of the local TESA at the Zuider Zee Supper Club. Norm Lubow gave a short talk on last year's activities and this year's state convention to be held here.

*Sheboygan County*—The new sales tax filled the air with questions at a meeting of TESA at the Grand Hotel. Other business included a brief discussion on licensing and the addition of new bad credit risks to the association's master list.

*Milwaukee*—Committee chairmen summarized last year's activities at TESA's regular meeting at Covics Amewood Hall. Membership committee reported that their campaign netted several new members last year. Technical Standards reported that 67 technicians' certificates have been issued to date. Activities for the year saw a group medical insurance plan adopted by the association and a lot of work done toward licensing technicians in the state. END

### 50 Years Ago

In Gernsback Publications

#### HUGO GERNSBACK, Founder

Modern Electrics.....	1908
Wireless Association of America.....	1908
Electrical Experimenter.....	1913
Radio News.....	1919
Science & Invention.....	1920
Practical Electrics.....	1921
Television.....	1927
Radio-Craft.....	1929
Short-Wave Craft.....	1930
Television News.....	1931

Some larger libraries still have copies of Modern Electrics on file for interested readers.

#### In June, 1912, Modern Electrics

Transmitting Photographs by Wire.  
 Detector Crystal Tester.  
 Wireless Legislation: Senate Bill S-6412.  
 Loud Acoustical Reproduction of Wireless Signals, by Stanley E. Hyde.  
 Underwriters Rules for Wireless Installations.  
 Ideal Oscillation Transformer, by Moore Stuart.  
 A New Type of Variable Condenser, by P. Mertz.  
 Cat Whisker Detector, by Earl Zander.  
 Wireless Outfit For a Dollar, by Lance Boyd.  
 Balanced Detector Stand, by M. E. Armstrong.

## WANTED

December 1911  
 Number of  
 MODERN  
 ELECTRICS

Must be in good condition. State price. Address:

Hugo Gernsback  
 154 W. 14th St., New York 11, N.Y.

# ELECTRONICS

## Engineering-Technicians

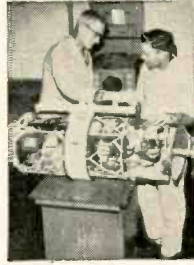

Heald's Microwave and Radar Laboratory Equipment.

Bachelor of Science Degree, 30 Months

Save Two Years' Time

- Radio-Television Plus Color Technician (12 Months)
- Electronics Engineering Technology (15 Months)
- Electronics Engineering (B.S. Degree)
- Electrical Engineering (B.S. Degree)
- Mechanical Engineering (B.S. Degree)
- Civil Engineering (B.S. Degree)
- Architecture (B.S. Degree)

Approved for Veterans  
 DAY AND EVENING CLASSES

Write for Catalog and Registration Application.  
 New Term Starting Soon.

## HEALD'S ENGINEERING COLLEGE

Established 1863

Van Ness at Post, RE  
 San Francisco, Calif.

Your Name \_\_\_\_\_  
 Address \_\_\_\_\_  
 City \_\_\_\_\_  
 State \_\_\_\_\_

## GERNSBACK LIBRARY

Low-cost, paper-covered books on all phases of TV, radio, audio-high fidelity and practical electronics

ON SALE AT ALL BETTER PARTS DISTRIBUTORS

Multicore Sales Corp., Port Washington, N.Y.

For information, write Department MF382

# YOU SAVE MONEY!

RUSH US YOUR  
 LIST OF HI-FI  
 COMPONENTS  
 FOR A SPECIAL  
 QUOTATION

WRITE FOR FREE  
 AUDIO DISCOUNT  
 CATALOG A-15

New low prices on  
 amplifiers, tuners, tape  
 recorders, speakers, etc.

**KEY** ELECTRONICS CO.  
 120 LIBERTY ST.  
 NEW YORK 6, N.Y.

## 2 NEW G/L BOOKS

Get a complete grasp of  
**RADIO and TV**

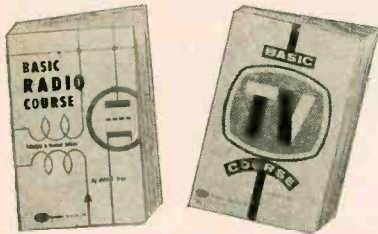

### BASIC RADIO COURSE

Revised and greatly enlarged

By John T. Fry No. 104—224 pages. \$4.10  
(cloth bound, \$5.75)

The original book sold out completely through eight reprints! Now here's the spanking new revised edition bulging with lots of new circuits and information with all the dated stuff dropped. And the author's good-humored style remains the same. Learning—from Ohm's law right up to advanced techniques—is fun.

Must reading for anyone serious about radio.

#### Some of the contents

Ohm's Law • Resistance • Induction • Capacitance • Reactance • Impedance • Phase • Resonance • Vacuum tubes • Power supplies • Sound and Speakers • Amplifiers • Demodulation • Selectivity • Converter Stage • Oscillators • Signals in Space • Transistor Radio • Instruments and Tools • Servicing Techniques

### BASIC TV COURSE

By George Kravitz No. 105—264 pages. \$4.10  
(cloth bound, \$5.75)

The up-to-date TV book on today's TV receivers. Throws out old schematics and concentrates on what makes modern sets tick. All straight facts in light, readable style from a bench man's point of view.

#### Some of the highlights covered

Forming the Picture • How the Picture Tube Works • The TV Signal • The TV Receiver • Antennas and Tuners • How the Video IF Works • Video Detector and AGC • Video Amplifier at Work • How the Sync Section Works • How the Sweep Section Works • How the Sound Section Works • Low Voltage Supply • Horizontal Output and High Voltage Supply • Transistor Portable TV • Review

See your distributor—Or mail this coupon

GERNSBACK LIBRARY, INC., Dept. 62  
154 West 14th St.  
New York 11, N. Y.

Please send me the books checked

Basic Radio  paperback  cloth cover  
 Basic TV  paperback  cloth cover

NAME \_\_\_\_\_

STREET \_\_\_\_\_

CITY \_\_\_\_\_ ZONE \_\_\_\_\_ STATE \_\_\_\_\_



### TRY THIS ONE

### USING CLAMP-AROUND VOLT-AMMETERS

In our work of repairing appliances and small electrical control components, current drain is often so small as to make an accurate reading difficult when using a clamp-on volt-ammeter.

In such cases, we take 10 turns of one feed wire through the jaws of the clamp-on. When this is done, the meter will multiply the load reading by 10. Thus a current drain of 0.2 amps will give a 2-ampere reading. In many instances, looping the feeder wire through only two or three times is enough for easy reading.—H. Muller

### TURNING TV STANDOFFS

The often difficult task of screwing TV standoff insulators into house siding is simple if you do it with your drill. Remove the bakelite handle and terminal screws from a phone plug, then

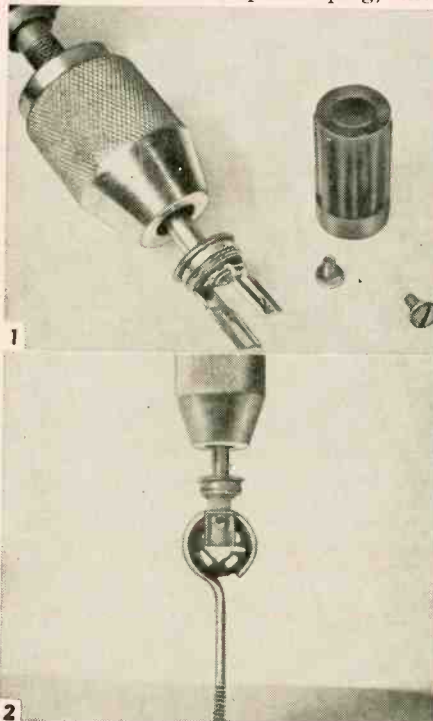

chunk the plug in your hand drill (Fig. 1). Now you can use this drill to simplify turning TV standoffs (Fig. 2).—  
John A. Comstock

### SOLDERING-GUN REPAIR

An excellent substitute for one of the tip-holding nuts on a soldering gun is a self-tapping screw threaded into

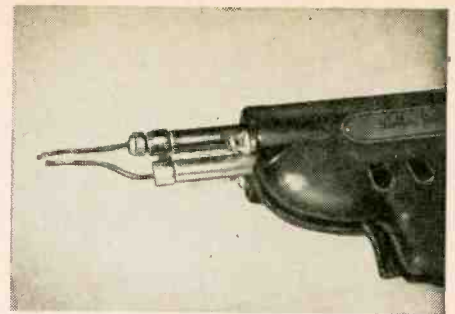

one of the holes into which the tip prongs are normally inserted. The screw will provide a good electrical contact. Any tendency of the tip to heat more slowly after a while can be remedied by loosening and retightening the screw, breaking the oxide film formed at the point of contact.—Leonard I. Kindler

### MIRROR MAGNIFIES MARKINGS

A shaving mirror of the magnifying type (see photo) makes it quite a bit easier for you to read markings on

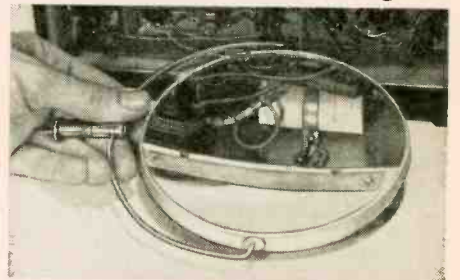

components in a circuit. Although the markings must be read in reverse, they are magnified several times by the mirror.—Jerome A. Carlson

### TRY STRANDED SOLDER

Hammer or pinch wire solder flat, then cut it into narrow strands. This reduces the solder melting temperature,

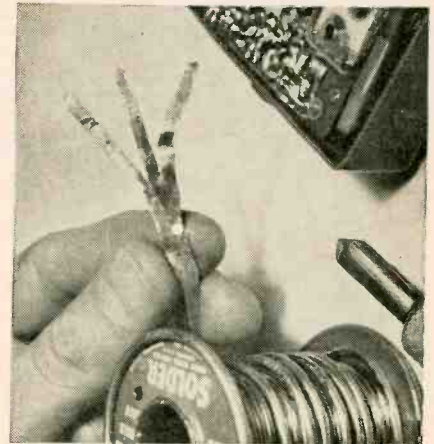

allows better control of quantity applied (essential when soldering in transistorized gear) and permits the use of a smaller iron and less heat.—  
James C. Conrad

### TVI TRAP

The trimmers from a discarded if transformer and a couple of scraps of 300-ohm ribbon line can be used as an effective interference trap. The shorted length of ribbon line (3½ inches for the high channels and 4½ inches for the low) is an inductance that is tuned by

the trimmer capacitor. Slip the antenna lead connected to the TV set through the space between the trimmer terminals. Tape the short lengths of twin-lead to the receiver transmission line. The looser the coupling to the antenna, the more selective the trap will be.



If interference is exceptionally severe, it may be possible to find a point of maximum effectiveness by sliding a shorting bar (aluminum foil will do) along the lead-in. The point where the interference is least (it's usually within 10 feet of the antenna terminal board) is the place to tape the trap.—*E. C. Carlson*

### PIPE TOOL DEBURRS CHASSIS

Hacksaw a "V" into one end of a short length of pipe for a deburring tool that makes chassis edge burr removal

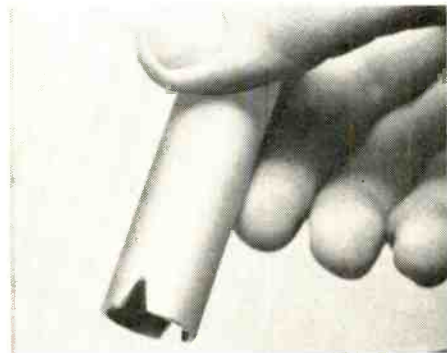

quick and easy. Simply draw the tool toward you over the ragged chassis edge. Those who hacksaw a metal chassis while building or servicing electronic gear will find this tool very useful.—*Joe C. Allen* END

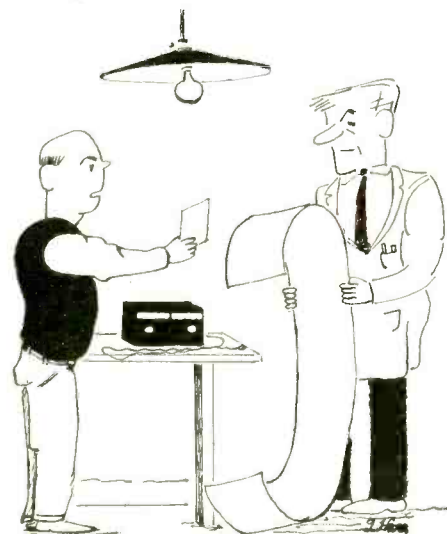

"This small sheet includes the description, operating instructions, schematic diagram, alignment procedure and trouble-shooting chart. The large sheet consists of all the information you need for restringing the dial cord."

## TV Tuner Problems?

Simply send us your defective tuner complete: include tubes, shield cover and any damaged parts with model number and complaint.

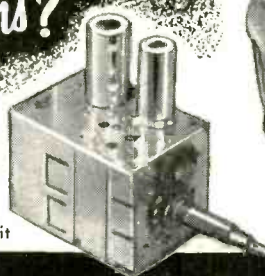

Send for details and FREE Mailing Kit

## CASTLE TV TUNER SERVICE, INC.

5715 NORTH WESTERN AVENUE, CHICAGO 45, ILLINOIS  
653 PALISADE BLVD., CLIFFSIDE PARK, NEW JERSEY  
IN CANADA: 136 MAIN STREET, TORONTO 13, ONTARIO

Castle Overhaul

ALL MAKES ONE PRICE  
90 Day Warranty **9<sup>95</sup>**

Tubes and Major Parts Extra

## SONIC-IMPULSE FISH ATTRACTOR

The perfect gift for that fishing friend, husband, or boy of yours . . . a new totally revolutionary device that actually brings fish to you! The transistorized SON-R-LURE, developed by electronic engineers, emits the sounds of injured bait fish (can be set to higher frequencies to simulate sounds of large insects) . . . attracts game fish from as far as .2 mi. away! Effective in both fresh water and ocean. \$8.95, ppd., plus 36¢ Calif. Tax. Send check or money order to H. McCune Co., Dept. RE, P.O. Box 662, Encino, Calif.



WE WANT TO BUY CERTAIN TYPES OF UNUSED TUBES AND ELECTRONIC EQUIPMENT

**BARRY ELECTRONICS CORPORATION**

512 BROADWAY, NEW YORK 12, NEW YORK WAlker 5-7000

# Television RADIO-ELECTRONICS Electricity ELECTRONICS IN NEW SHOP-LABS OF COYNE

## TRAIN QUICKLY! OLDEST, BEST EQUIPPED SCHOOL OF ITS KIND in U.S.

Get practical training in New Shop-Labs of Coyne. Prepare for a better job and a successful future in a top opportunity field. Advanced education or previous experience not needed. Employment service to graduates.

### Enroll NOW—Pay Later

Finance Plan and Easy Payment Plan. Also Part Time Employment help for students.

**FREE BOOK** Clip coupon or write to address below for Free Illustrated Book. "Guide to Careers"—Describes all training offered. No obligation and No Salesman Will Call. Act NOW.

B. W. Cooke, Jr., President  
**COYNE ELECTRICAL SCHOOL** CHARTERED NOT FOR PROFIT  
Established 1895  
1501 W. Congress Pkwy., Chicago, Dept. A2-N

COYNE Electrical School  
1501 W. Congress Pkwy., Chicago 7, Ill.  
Dept. A2-N

Send FREE book "Guide to Careers" and details of all training you offer. However, I am especially interested in:

ELECTRICITY  TELEVISION  BOTH FIELDS

NAME.....

ADDRESS.....

CITY.....STATE.....

## 4-CHANNEL AUDIO MIXERS



Switchcraft 4-channel high impedance mixers allow you to feed up to 4 signals into a single output to your recorder or amplifier.

Transistorized Mixers give you low noise level, low distortion, response—20 to 20,000 cycles. Individual gain adjustment in each of 4 channels. Unique Lever Switch allows you to select 2 Stereo channels or 4 Monaural channels. Input and Output Jacks on back of unit accept standard 2-conductor Phone Plugs. Tan finish, metal cabinet. See list below for all types.

**TRANSISTORIZED MIXERS (battery incl.)**  
Part No. 306TR—Stereo-Monaural (with switch) U.S.A. List \$37.50  
Part No. 301TR—Monaural only U.S.A. List \$30.00

**NON-TRANSISTORIZED MIXERS**  
Part No. 306—Stereo-Monaural (with switch) U.S.A. List \$22.50  
Part No. 301—Monaural only U.S.A. List \$19.50

Contact your dealer or write us for name of dealer nearest you.

**SWITCHCRAFT INC.**

5579 N. Elston Ave., Chicago 30, Ill.  
Canadian Rep.: Atlas Radio Corp., Ltd.,  
50 Wingold Ave., Toronto, Ontario

# NEW SAMS BOOKS

NEWLY REVISED! 3rd EDITION OF  
THE FAMOUS HOWARD W. SAMS

## Transistor Substitution Handbook

- ★ 13,600 DIRECT SUBSTITUTIONS
- ★ 3,400 MORE SUBSTITUTIONS THAN IN PRIOR EDITION

Includes basing diagrams, polarity identifications and manufacturers for over 4000 transistor types.

Volume 3 of this famous handbook has been updated and enlarged to provide all the data needed to select suitable transistor replacements. Includes special section showing 1,514 American replacements for Japanese transistors, PLUS a semiconductor diode and rectifier guide containing 750 substitutions. Explains why substitution is possible, when it is appropriate and when not, and precautions to observe. Covers all types of transistors. 112 pages; 5 1/2 x 8 1/2 in. Only **\$1.50**

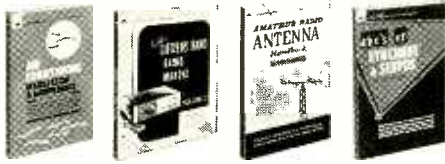

## Air Conditioning Installation & Maintenance

This down-to-earth handbook will help you cash in on the tremendous potential in servicing all types of air conditioning units. Covers: General Description of Air Conditioners; Theory and Operation; The Electrical System; Installation Kits; Automobile Air Conditioners; Central Air Conditioning Systems; Tools and Test Equipment; Air Conditioner Repairs; Inspection & Preseason Preparation; Winterizing & Storage; Parts Procurement. 160 pages; 5 1/2 x 8 1/2 in. Only **\$2.95**

## Citizens Band Radio Manual, Volume 2

Famous PHOTOFACT® Folders and Standard Notation Schematics covering thirty 1961 CB Transceiver models. Brands covered are: Arkay, Bendix, Dewald, Duo Com, Eico, Globe, Heath, Johnson, Lafayette, Morrow, Osborne, Poly Com, RCA, Sonar, Sonarcom, Spokesman, Utica, Vocaline, Webster. Includes text section describing various types of equipment. 160 pages; 8 1/2 x 11 in. Only **\$2.95**

## Amateur Radio Antenna Handbook

Harry D. Hooton (W6TYH) has written a long-needed book to help the ham wisely select the best antenna system for his needs and to get optimum performance. Chapters cover propagation and antenna fundamentals; theory and practical application of antenna design; transmission lines; impedance selection and coupling; practical data on design and construction of directional arrays; tower design and installation information. 160 pages; 5 1/2 x 8 1/2 in. Only **\$2.95**

## ABC's of Synchros & Servos

Alan Andrews fully explains the fundamentals of synchros and servomechanisms, how they work and where they are used. Describes all types of individual and combination units. Eight chapters cover: Individual control systems; position transducers; synchros; modulators and demodulators; servo amplifiers; magnetic and rotary amplifiers; actuators; and an analysis of complete systems. 96 pages; 5 1/2 x 8 1/2 in. Only **\$1.95**

## NEW! SERVICING TRANSISTOR RADIOS, VOL. 11

Covers 73 models produced in 1960-61. Complete PHOTOFACT® servicing data for each model. 160 pages; 8 1/2 x 11 in. Only **\$2.95**

## HOWARD W. SAMS & CO., INC.

Order from your Sams Distributor today, or mail to Howard W. Sams & Co., Inc., Dept. F-22 1720 E. 38th St., Indianapolis 6, Ind.

Send me the following books:

- Transistor Substit. Handbook Vol. 3 (SSH-3)
- Air Conditioning Install. & Maint. (ACM-1)
- Citizens Band Radio Manual Vol. 2 (CB-2)
- Amateur Radio Antenna Handbook (AMA-1)
- ABC's of Synchros & Servos (ASE-1)
- Servicing Transistor Radios Vol. 11 (TSM-11)

\$.....enclosed.  Send Free Book List

Name \_\_\_\_\_

Address \_\_\_\_\_

City \_\_\_\_\_ Zone \_\_\_\_\_ State \_\_\_\_\_

IN CANADA: A. C. Simmonds & Sons, Ltd., Toronto 7 (outside U.S.A. priced slightly higher)



**ESSENTIAL CHARACTERISTICS** (Receiving, Five-Star, Special-Purpose and Picture Tubes), by R. G. Kempton, J. H. Robb, P. E. Hatfield. General Electric Co., Receiving Tube Dept., Owensboro, Ky. 5 1/2 x 8 1/2 in. 300 pp. \$1.50.

The ninth edition of this standard work runs 300 pages. Includes for the first time characteristics of G-E's new Universal capacitors, as well as cross-reference listings of the prototypes of Five-Star and other special purpose tubes.

**AMPLIFIER CIRCUITS**, by Thomas M. Adams. Howard W. Sams & Co. Inc., 1720 E. 38 St., Indianapolis, Ind. 5 1/2 x 8 1/2 in. 136 pp. \$2.95.

Diagrams (some in color) and simple language explain amplifier theory and current paths.

**ESSENTIALS OF MATHEMATICS**, by Russell V. Person. John Wiley & Sons Inc., 440 Park Ave. South, New York 16, N.Y. 6 x 9 in. 646 pp. \$7.

Practical introduction to algebra, geometry, logs and trig for home-study or class.

**INTRODUCTION TO ELECTRIC CIRCUIT ANALYSIS**, by Ralph E. Armington and Carl Volz. Prentice-Hall Inc., Englewood Cliffs, N.J. 6 x 9 in. 243 pp. \$9.

Basic engineering text; requires a knowledge of calculus.

**ALLIED ELECTRONICS DATA HANDBOOK**, (3rd Edition) (Formulas and Data Most Commonly Used In Electronics), Edited by Lieut. Comdr. Nelson M. Cooke, USN. Allied Radio Corp., 100 N. Western Ave., Chicago 80, Ill. 6 x 9 in. 80 pp. 35¢.

The new edition contains all the old formulas and tables, together with a great deal of new material, including up-to-date information on transistors and American-foreign tube interchangeability.

**ELECTRONIC ENGINEERING PRINCIPLES** (3rd Edition), by John D. Ryder. Prentice-Hall, Inc., Englewood Cliffs, N. J. 6 x 9 in. 428 pp. \$12.65.

A standard engineering text that integrates the study of tube and transistor circuits.

**MINIATURIZATION**, edited by H. D. Gilbert. Reinhold Publishing Corp., 430 Park Ave., New York 22, N.Y. 6 x 9 in. 306 pp. \$10.

Design, manufacture and maintenance of components and assemblies used in missiles, medicine, computers, etc., are described by 16 experts.

**ELECTRONIC GAMES & TOYS YOU CAN BUILD**, by Len Buckwalter. Howard W. Sams & Co., 1720 E. 38 St., Indianapolis, Ind. 5 1/2 x 8 1/2 in., 128 pp. \$2.50.

You can make your own games and do mystifying tricks with the aid of simple tools and a few electronic components.

**SILICON CONTROLLED RECTIFIER MANUAL**, by F. W. Gutzeiler, D. R. Grafham, D. V. Jones, H. R. Lowry, J. E. Mungast, R. R. Rottier, G. E. Snyder, T. P. Sylvan, E. E.

Von Zastrow. Application Engineering Ctr. General Electric, West Genesee St., Auburn, N. Y. 5 1/2 x 8 1/2 in. 352 pp. \$1.50.

This second edition of the *Silicon Controlled Rectifier Manual* has jumped from 255 to 352 pages. With the additional material and several new contributors, it remains more than ever the industry's manual on the subject.

**ABC'S OF RADAR**, by Alan Andrews. Howard W. Sams & Co. Inc., 1720 E. 38 St., Indianapolis, Ind. 5 1/2 x 8 1/2 in. 112 pp. \$1.95.

A simple but thorough text for use as a reference or as a study guide for the radar endorsement on your FCC license.

**ELECTRONIC MUSIC AND MUSIQUE CONCRÈTE**, by F. C. Judd. Neville Spearman Ltd., 112 Whitfield St., London W 1, England. 5 1/2 x 8 1/8 in. 74 pp. 16 shillings.

A complete explanation and description of this new type of music, including circuits to generate it (with constants of the various types of electronic tone sources). Appendices, bibliography and index.

**MAGNETIC AMPLIFIER ANALYSIS**, by David L. Lafuze. John Wiley & Sons Inc., 440 Park Ave. So., New York 16, N.Y. 5 3/4 x 9 in., 252 pp. \$9.75.

How to design half-wave and full-wave amplifiers. Sample calculations are included. **END**

## CORRECTIONS

There is an error in the caption for Fig. 1 of the article "PA Speakers—Why So Many Types?" on page 55 of the March issue. It should read "Typical horn characteristics. The upper diagrams are for horns of different tapers and equal mouth areas. The lower ones are for horns with equal tapers and different mouth areas."

We thank the author, Victor Brociner, for bringing this to our attention.

In Fig. 4 of the article "New Directions in Hi-Fi Amplifiers" (page 37 of the April issue) there should be a 68-ohm 1 watt resistor connecting the junction of the two driver transformer primaries and the 500-µf filter to the -23-volt bus.

Our thanks to Mr. Walter R. McCarty of Midland, Tex. for calling this to our attention.

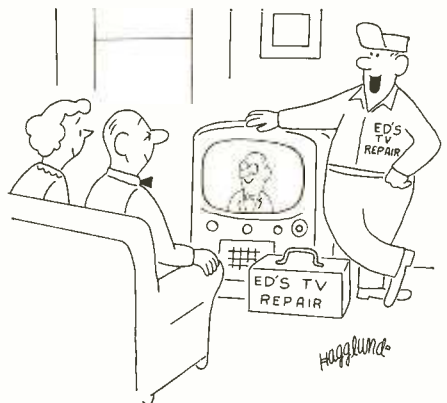

"The following program is brought to you by the skill and fast work of Ed's TV Repair."



# SCHOOL DIRECTORY

## LEARN ELECTRONIC ORGAN SERVICING

This new, high paying profession can now be learned easily in your spare time.

- ★ Complete Training — All Makes and Models
- ★ Scientific Teaching Aids Make Learning Easy
- ★ No Prior Knowledge of Electronics Necessary

GET FULL DETAILS ON THIS AMAZING COURSE

WRITE FOR FREE BOOKLET

**NILES BRYANT SCHOOL**  
Dept. L, 3731 Stockton Blvd.  
Sacramento 20, California

## ENGINEERING EDUCATION for the Space Age

**NORTHROP INSTITUTE of Technology** is a privately endowed, nonprofit college of engineering offering a complete Bachelor of Science Degree Program and TWO-YEAR accredited technical institute curricula. Students from 50 states, many foreign countries. Outstandingly successful graduates employed in aeronautics, electronics, and space technology. Write today for catalog—no obligation.

**NORTHROP INSTITUTE OF TECHNOLOGY**  
1181 West Arbor Vitae Street, Inglewood 1, California

## B. S. DEGREE IN 36 MONTHS

INDUSTRY & GOVERNMENT NEED 50,000 NEW ENGINEERS A YEAR!

Accelerated year-round program puts you in the job-market a whole year early! Also B.E. degree in 27 mos. Aero., Chemical, Civil, Electrical, Electronics, Math, Chemistry, Physics. Quality instruction; widely recognized. Graduates employed from coast to coast. Self-help program. Modest rate. Start June, July, Sept., Jan., March. Catalog: 1582 E. Washington Blvd., Ft. Wayne 2, Ind.

## INDIANA TECHNICAL COLLEGE

LEARN

**RADAR MICROWAVES  
COMPUTERS—TRANSMITTERS  
CODE • TV • RADIO**

Phila. Wireless Technical Inst.  
1533 Pine St., Philadelphia 2, Pa.  
A Non-Profit Corp.  
Founded in 1908

Write for Free Catalog to Dept. RE-6  
Classes now forming

## GET INTO ELECTRONICS

V.T.I. training leads to success as technicians, field engineers, specialists in communications, guided missiles, computers, radar and automation. Basic & advanced courses in theory & laboratory. Electronic Engineering Technology an ECPD accredited Technical Institute curriculum. Assoc. degree in 20 mos. B.S. also obtainable, G.I. approved. Graduates in all branches of electronics with major companies. Start Sept., Feb. Dorms, campus High school graduate or equivalent. Catalog.

**VALPARAISO TECHNICAL INSTITUTE**

Dept. C Valparaiso, Indiana



## ENGINEERING DEGREES



5719-M Santa Monica Blvd. Hollywood 38, Calif.

E.E.  
Option Electronics,  
Mechanical.  
Also in Liberal Arts  
earned by  
**HOME STUDY**  
Resident Classes Also  
Available If Desired  
Specify course preferred  
**PACIFIC INTERNATIONAL  
COLLEGE OF ARTS  
& SCIENCES**  
Primarily a correspondence  
school  
Chartered 1935

## ENGINEERING

Learn more . . . earn more. **B. S. DEGREE IN 27 MONTHS** in Engineering. **IN 36 MONTHS** in Business Administration. Small classes. *Low costs.* Enter Sept., Jan., Mar., June. Write **J. G. McCarthy** for Catalog and Your Career Book.

**TRI-STATE COLLEGE**  
2462 College Avenue • Angola, Indiana

FREE!

## ELECTRONICS CAREER KIT

If you're interested in breaking into a good-paying job in Radio-TV-Electronics, I.C.S. will send you absolutely free a famous Career Kit with 3 famous booklets that have helped thousands of others—just like yourself—on the road to real success. Includes:

- 1 "HOW TO SUCCEED" Career Guide — 36-page gold mine of career tips and information.
- 2 "JOB CATALOG" of opportunities in your field of interest.
- 3 "SAMPLE LESSON" (math) to demonstrate the famous I.C.S. method.

Send today for your free I.C.S. Career Kit with these 3 famous booklets. There's no obligation. This may be the big break you've been waiting for. Mark and mail the coupon today.

### INTERNATIONAL CORRESPONDENCE SCHOOLS

Dept. W7420E, Scranton 15, Penna.

Please send free Career Kit with 3 famous booklets

- General Electronics  Radio-TV Serv'g  Practical Electrician  
 Industrial Electronics  Sound Equip. Serv'g  Profess'l Eng. (Elec.)  
 Radio-TV Eng'g  Electrical Eng'g  Electrical Drafting  
 Electronic Servicing  Electrical Tech.  Other \_\_\_\_\_

Name \_\_\_\_\_ Age \_\_\_\_\_

Address \_\_\_\_\_

City \_\_\_\_\_ State \_\_\_\_\_

## FREE CAREER BOOKLET



to guide you to a successful future in

## ELECTRONICS RADIO-TV COMPUTERS ELECTRICAL ENGINEERING

This interesting pictorial booklet tells you how you can prepare for a dynamic career as an Electrical Engineer or Engineering Technician in many exciting, growing fields:

**MISSILES • RADAR • RESEARCH  
ELECTRICAL POWER • ROCKETRY  
AUTOMATION • AVIONICS  
SALES • DEVELOPMENT**

Get all the facts about job opportunities, length of study, courses offered, degrees you can earn, scholarships, part-time work — as well as pictures of the Milwaukee School of Engineering's educational and recreational facilities. No obligation — it's yours free.

## MILWAUKEE SCHOOL OF ENGINEERING

### MAIL COUPON TODAY!

**MILWAUKEE SCHOOL OF ENGINEERING**  
Dept. RE-662, 1025 N. Milwaukee St.  
Milwaukee, Wisconsin MS-113

Please send FREE "Your Career" booklet  
I'm interested in  Electronics  Radio-TV  
 Computers  Electrical Engineering  
 Mechanical Engineering  
 (PLEASE PRINT)

Name \_\_\_\_\_ Age \_\_\_\_\_

Address \_\_\_\_\_

City \_\_\_\_\_ Zone \_\_\_\_\_ State \_\_\_\_\_

I'm eligible for veterans education benefits.

Discharge date \_\_\_\_\_

**R-E****Classified****ADS**

Rates—50¢ per word (including name, address and initials. Minimum ad 10 words. Payment must accompany all ads except those placed by accredited agencies. Discount, 10% for 12 consecutive issues. Misleading or objectionable ads not accepted. Copy for August issue must reach us before June 12, 1962.

RADIO-ELECTRONICS, 154 West 14 St., New York 11, N. Y.

**MISCELLANEOUS**

**INDEPENDENT THINKERS**—investigate Humanism! Free literature. **AMERICAN HUMANIST ASSOCIATION**, Dept. REI, Yellow Springs, Ohio.

**MODEL RELEASES**, Forms 100—\$1.00. **STUDIO**, Box 1143-F, Santa Barbara, Calif.

**PRINTING PRESSES**, type, supplies. List 4¢. **TURNBAUGH SERVICE**, Mechanicsburg, Pa.

**BUY/RENT COMEDY, PARTY RECORDS**. Sampler and catalogs, \$1.00. **DRC**, Dept. RE-6, 11024 Magnolia Blvd., No. Hollywood, Calif.

**BOOK 200 Electric Stunts \$1.00. CUTT-RADO**, 875 Arastradero, Palo Alto, Calif.

**DO SECRET INVESTIGATIVE WORK** With supersensitive, directional microphone. Detects a whisper at great distances. Easily constructed for \$7. Step by step plans \$1.95. **DEE COMPANY**, Box 7263-A, Houston 8, Texas.

**HOMEBREWING!** . . . Beers . . . Wines. Complete Instruction Manual, \$1.00 (guaranteed!). **CRYSTAL'S 28-BRK2**, Millburn, N.J.

**AUTOMATIC ASHTRAY** with heat-sensitized coil ends cigarette-burned furniture or fire. Gently tilts burned-down cigarette into ashtray. **IMPORT DELFTWARE**, Pair, \$3.00. **DEPT. 80A**, 516 Otto Ave., Beverly, N.J.

**SERVICES**

**TV TUNERS**—rebuilt or exchanged, \$9.95 complete—all types—fast, guaranteed service. Send tuner with all parts to: **L. A. TUNER EXCHANGE**, 4611 W. Jefferson Blvd., Los Angeles 16, Calif.

**TRANSISTORIZED products dealers catalog**, \$1. **INTERMARKET**, CPO 1717, Tokyo, Japan.

**ALL MAKES OF ELECTRICAL INSTRUMENTS AND TESTING** equipment repaired. New and used instruments bought, sold, exchanged. **HAZELTON INSTRUMENT CO.**, 128 Liberty St., New York, N.Y.

**PRINTED CIRCUIT MATERIAL BAR-GAIN**. Single copper-clad 1/16" phenolic 9" x 10 1/2" sheet, \$1.00 postpaid. **BUCHAN**, 2994 Sibley Highway, St. Paul 18, Minn.

**TV Tuners rebuilt or exchanged, \$9.95.** Most tuners shipped same day received. **VALLEY TUNER SERVICE**, 18530 Parthenia, Northridge, Calif.

**FOR SALE****Electronics**

**INVESTIGATORS**, write for free brochure on latest subminiature electronic listening devices. **DEPT 6E**, 11500 NW 7th Ave. Miami 50, Fla.

**PRECISION RESISTORS**, carbon-deposit. Guaranteed 1% accuracy. Millions in stock. 1/2 watt, 8¢, 1-watt, 12¢, 2-watt, 15¢. Leading manufacturers. **ROCK DISTRIBUTING CO.**, 902 Corwin Rd., Rochester 10, N.Y.

**SHORT CIRCUITS** pinpointed within 5 feet or your \$4.50 back. Own a patented pocket-size Dynamic Short Locator. **DYNAMICO**, 11370 SW 60th Terr., Miami 43, Fla.

**SCHEMATICS**, repair information. Television \$1.50. Radio 75¢. Send make and model. **SCHEMATICS UNLIMITED**, Box 65, Flushing 64, N.Y.

**SCHEMATIC DIAGRAMS**, exact replacement parts orders: Japanese transistor or tube radios, recorders, transceivers, electronics equipment. Give model and manufacturer, \$1.00. **TECHSERVICES**, CPO 849, Tokyo, Japan.

**PROFESSIONAL ELECTRONIC PROJECTS**—Organs, Timers, Computers, etc.—\$1 each. List free. **PARKS**, Box 1665, Lake City, Seattle 55, Wash.

**ELECTRONIC SURPLUS CATALOG**, 5,000 items. Send 10¢. **BILL SLEP CO.**, Drawer 178R, Ellenton, Fla.

**BEFORE YOU BUY** Receiving Tubes or Hi-Fi Components send now for your giant **FREE Zalytron current catalog**—featuring nationally known Zalytron First Quality TV-Radio Tubes, Hi-Fi Stereo Systems, Kits, Parts, etc. All priced to Save You Plenty—Why Pay More? **ZALYTRON TUBE CORP.**, 220 W. 42nd St., N.Y.C.

**SAVE DOLLARS** on Radio, TV Tubes. Brand new. Parts at less than manufacturer's cost. 100% Guaranteed. No re-brands or pulls! Request bargain bulletin. **UNITED RADIO**, Box 1000-R, Newark, N.J.

**DIAGRAMS FOR REPAIRING RADIOS**, \$1; television \$2. Give make and model. **DIAGRAM SERVICE**, Box 672 RE, Hartford 1, Conn.

**FREE BRAND-NEW FAMOUS-BRAND TUBES CATALOG**. Discounts to 75% from list. Picture tubes at 75¢ inch up; parts, kits at 1/10 original cost. Phono needles, tube testers, silicones, seleniums, 7" TV bench test tube — \$6.99 — and more. **ARCTURUS ELECTRONICS CORP. RE**, 502 22nd St., Union City, N.J.

**SMALL SET BUILDER'S** big information catalogue—25¢, refundable. **LABORATORIES**, 1131-B Valota, Redwood City, Calif.

**CONVERT ANY TELEVISION TO SENSITIVE**, Big-screen oscilloscope. Only minor changes necessary. Plans \$1.95. **RELCO**, Box 10563, Houston 18, Texas.

**BUILD AMAZINGLY SENSITIVE TRANSISTORIZED TREASURE FINDER**. Locate deep buried treasure. Available partially wired. Inexpensive. Simple, illustrated plans, details. \$2. **DEEKITS**, Box 7263-E, Houston 8, Texas.

**MONEY-BACK GUARANTEE**. Pocketable hi-fi six-transistor radio \$9.95. Powerful extended-range five-transistor transceiver, \$16.95; pair \$29.95. All postpaid! Money order to **TECHSERVICES**, CPO Box 849, Tokyo, Japan.

**Audio—Hi-fi**

**TAPE recorders, Hi-Fi components, Sleep-learning equipment, Tapes, Unusual values.** Free catalog. **DRESSNER**, 1523R Jericho Turnpike, New Hyde Park, N.Y.

**DON'T BUY HI-FI COMPONENTS, Kits, Tape, Tape Recorders** until you get our low, low return mail quotes. "We Guarantee Not To Be Undersold." Wholesale Catalog Free. Easy Time Payments Plan, 10% down—up to 24 months to pay. **HIFIDELITY CENTER**, 220 RC E 23 St., New York 10, N.Y.

**HI-FI AMPLIFIERS, TUNERS, SPEAKERS, WALKIE-TALKIES, Radios, Telescopes, Microscopes, Cameras, low prices.** Free Catalog. **GM PHOTOELECTRONICS**, 623 Gay St., Knoxville 2, Tenn.

**SAVE 30%**. Stereophonic music on tape. Request tape, recorder Catalog R-1. **SAXITONE TAPE SALES**, 1776 Columbia Rd, Washington 9, D.C.

**RENT STEREO TAPES**—over 2,500 different—all major labels—free catalog. **STEREO-PARTI**, 811-RE, Centinela Ave., Inglewood 3, Calif.

**SALE ITEMS.** Component quotes. Bulk tapes. **BAYLA CO.**, Box 131-RE, Wantagh, N.Y.

**GARRARD Model A** and a Dual 1006 or Miracord Studio record changer, Pickering 380C, Empire 108, Shure M 7 D or Miracord cartridge. Any changer cartridge combination \$64.50. Any three cartridges \$34.50, 25% deposit, balance COD. **PROFESSIONAL HI FI**, 248-52 Jericho Turnpike, Bellerose, N.Y.

**HIGH FIDELITY DEALERS, SERVICE-MEN.** Increase your income. Keep clients satisfied. Write for full story. No obligation. **WILLIAM N. GREER ASSOCIATES**, Consulting Engineers, 511 El Imparcial Building, San Juan, Puerto Rico.

**HUMLESS amplifiers** need dc filament power! 6.3V 1.5ADC full-wave bridge rectifier, sample with data \$2.00 postpaid. **ENGINEERING ASSOCIATES**, Dayton 10, Ohio

**SPEAKERS.** Quality hi-fi 12" woofer only \$8.98, also 12" PM Twin-Cone full-range hi-fi \$17.93. Have 3 1/2" tweeters, stiff cone, only \$1.49 each. Include shipping charges, excess amount refunded. **GENERAL ELECTRONICS**, 620 Eggert Rd., Buffalo 15, N.Y.

**General**

**FREE GIANT WHOLESALE CATALOG**, Electronics, HiFi, Tools, Tubes, Radios, Imports Housewares, Photos, optics, appliances, survival products. Write **LEKTRON 241** Everett Ave., Chelsea, Mass.

**U. S. GOVERNMENT SURPLUS**—Jeeps, \$264.00, Radios \$2.53, Guns, Typewriters, Cameras, Tools; thousands of items. Fabulously low surplus prices. Complete information sent immediately. Send \$1.00 to: **SURPLUS**, P.O. Box 512-NN, New Orleans 1, La.

COMMUNICATIONS, Teletype, unusual surplus bargains. Free Flyer. MDC, 923 W. Schiller, Philadelphia 40, Pa.

DIAL telephones, cradle type. Use for private systems, intercoms. etc. Recent Stromberg-Carlson. \$4.75 each. GUARANTEED, 4476 Van Ness, Fresno 4, Calif.

TRANSFIRE IGNITION. Transistor electronic. Save gas, tune-ups. Points, plugs last 50,000-100,000 miles. Improved cold-starting high-speed performance. Parts, complete conversions, kits from \$34.95. PALMER ELECTRONICS, RE-1, Carlisle, Mass.

## BUSINESS AIDS

BUSINESS CARDS, LABELS, RUBBER STAMPS. Send for free descriptive literature, HEIGHTS INDUSTRIES, 6121 C Street, Capitol Heights 27, Md.

LETTERHEADS — Billheads — Envelopes — Statements. Super special. Free details. OKAYPRINTER, Martins Ferry, Ohio.

TV-RADIO SERVICE DEALERS. No investment—We furnish you complete consignment stock RAYTHEON tubes. Regular dealer discount plus premiums, free caddy, advertising. Write for information. OMEGA ELECTRONICS, Dept. R, 397 7th Ave., Brooklyn 15, N.Y.

BUSINESS CARDS, 1000 \$3.99. Rubber Stamps, 10 words, \$1.00. Catalog Free. ALCO, Box 244-R, Urbana, Ill.

## EDUCATION/INSTRUCTION

SLEEP LEARNING. Startling method 92% effective. Brochure free. ASR FOUNDATION, Box 21RE, Henry Clay Station, Lexington, Ky.

TAKE BACHELOR'S and Master's Degree correspondence courses from leading Universities! Directory of 6,000 courses—\$2.00. COLLEGE RESEARCH, North Highlands 14, Calif.

LEARN WHILE ASLEEP, Hypnotize with your recorder, phonograph or amazing new Electronic Educator endless tape recorder. Catalog, details free. SLEEP-LEARNING ASSOCIATION, Box 24-RD, Olympia, Wash.

NEW CONCEPT OF LEARNING SELF-HYPNOSIS! Now on tape or record! Free Literature. MCKINLEY-SMITH CO., Dept. T5, Box 3038, San Bernardino, Calif.

HYPNOTIZE: Practical Instruction Course, \$1.00 (guaranteed.) CRYSTAL'S 28-PRK2, Millburn, N.J.

PROFESSIONAL TAP DANCING SIMPLIFIED, \$1.00 WALTER KAZAKS, 234 E. 58 St., New York 22, N.Y.

## WANTED

CASH PAID! Sell your surplus electronic tubes. Want unused, clean radio and TV receiving, transmitting, special purpose, Magnetrons, Klystrons, broadcast types, etc. Want military & commercial lab/test and communications equipment such as G.R., H.P., AN/UPM prefix. Also want commercial receivers and transmitters. For a fair deal write BARRY, 512 Broadway, New York 12, N. Y. Walker 5-7000.

G-R, H-P, L&N, etc.; tubes, manuals, military electronics. ENGINEERING ASSOCIATES, 434 Patterson Road, Dayton 19, Ohio.

SALES-regional managers needed. All sections of the United States, to call on retailers. Product—the best German-made radio, stereo and hi-fi available. Send resume to SABA, Suite 502, Parkade Building, 519 Federal St., Camden 3, N.J.

WANTED—Circuits employing relays for games, computers. CAREY, 25 Arlington, Cambridge, Mass.

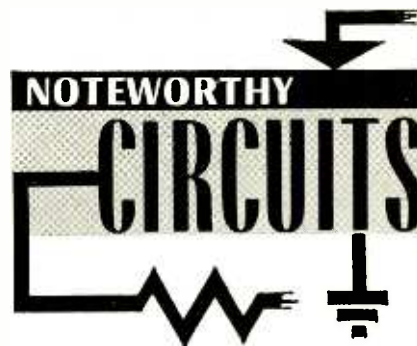

## MODIFIED BAXANDALL CIRCUIT

The treble section of a Baxandall negative-feedback type tone control uses a center-tapped 500,000-ohm linear potentiometer. The center-tapped pot can be eliminated by using the modified

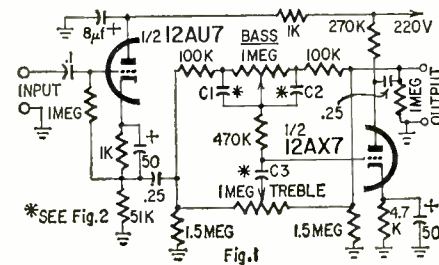

circuit (Fig. 1) taken from *Radio et TV* (Paris, France). Here, we have a 1-megohm untapped treble control with each end shunted to ground through a

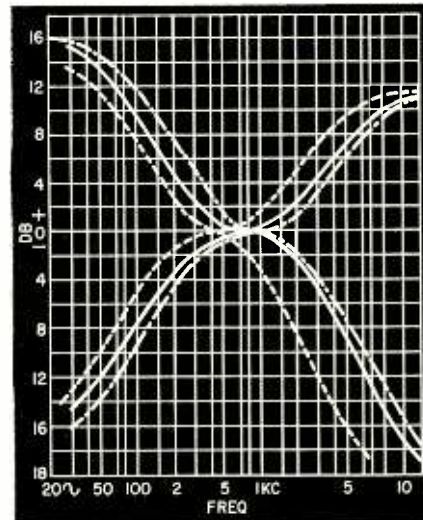

Fig. 2  
 --- C1-C2 .003 C3 100μf Fc CROSSOVER 1KC  
 - - - C1-C2 .005 C3 100μf 800~  
 ···· C1-C2 .005 C3 330μf 400~

1.5-megohm resistor. The curves in Fig. 2 show the response and crossover points of the bass and treble controls for various values of C1, C2 and C3.

Remember, this circuit like many low-level tone control circuits is susceptible to hum. Keep all leads as short as possible to avoid trouble.

## TUNING-FORK OSCILLATOR

A constant standard tone is often needed when tuning musical instruments. You can make one by adding an electronic drive to a standard tuning fork, as outlined in *Wireless World* (London, England). Fig. 1 shows the

transistorized fork driver. Fig. 2 shows the parts layout. The transistor type is not critical. You can use almost any audio type with a current gain of 40 or more.

Driver and pickup coils L1, L2 may be salvaged from a high-resistance headphone. Each should have a resistance around 1,000 ohms. C1 tunes L1 approximately to the fork frequency for improved efficiency and waveform purity. It may be omitted if high harmonic output is desired.

Mount the bias magnet, taken from an old meter, headphone or speaker, below the coils and not necessarily in

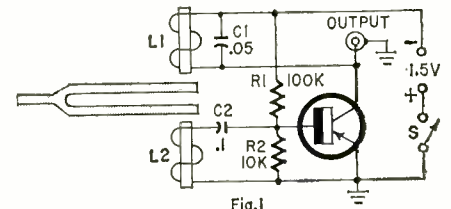

direct contact with the pole pieces. Adjust the spacing so the fork just vibrates. Excessive vibration mars accuracy and stability. Clamp the fork rigidly by its handle to prevent all lateral movement except the tine vibrations. Reverse the connections to L1 or L2 if the circuit does not oscillate.

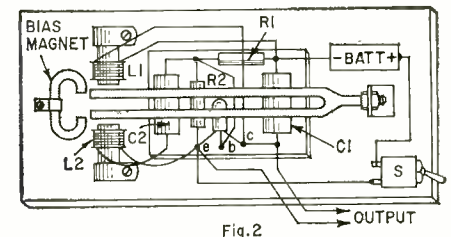

Tuning forks for B and C (494 and 522 cycles, respectively) are readily available and may be modified to provide a 500-cycle standard. A fork's frequency can be raised by carefully filing the tines and using a scope to compare its frequency with a known source. If the fork's frequency is too high, file the crotch.

For further information on electronically driven tuning forks as audio standards, see "Tuning-Fork Audio Frequency Standard," *CQ*, May 1956, and "Harmonic Generator with Tuning Fork Drive," *Electronic Engineering*, January 1956.

## ULTRA-SIMPLE TRANSISTORIZED DC MICROAMMETER

Most transistorized microammeters described previously use a zero-set

Radio-Electronics does not assume responsibility for any errors appearing in the index below.

**BUILD 10-25 RADIO CIRCUITS AT HOME**

with the New **PROGRESSIVE RADIO "EDU-KIT"®**  
**ALL Guaranteed to Work!**

only **\$14.95** up  
 Reg. U.S. Pat. Off.



- A Complete Home Radio Course**
- Receivers
  - Transmitters
  - Signal Tracers
  - Signal Injectors
  - Code Oscillator
  - Sq. Wave Generator
  - Amplifier
  - No Knowledge of Radio Necessary
  - No Additional Parts or Tools Needed
  - Excellent Background for TV
  - School Inquiries Invited

**WHAT THE "EDU-KIT" OFFERS YOU**

The "Edu-Kit" offers you an outstanding PRACTICAL HOME RADIO COURSE at a rock-bottom price. You will learn radio theory, construction and servicing. You will learn how to build radios, using regular schematics; how to solder and wire in a professional manner; how to service and troubleshoot radios. You will learn how to work with punched metal chassis as well as the new Printed Circuit chassis. You will learn the principles of RF and AF amplifiers and oscillators, detectors, rectifiers, test equipment. You will learn and practice code, using the Progressive Code Oscillator. In brief, you will receive a basic education in Electronics and Radio, worth many times the small price you pay.

**PROGRESSIVE TEACHING METHOD**

The Progressive Radio "Edu-Kit" is the foremost educational radio kit in the world, and is universally accepted as the standard in the field of electronics training. The "Edu-Kit" uses the modern educational technique of "Learn by Doing." You begin by building a simple radio. Gradually, in a progressive manner, and at your own rate, you construct more advanced multi-tube radio circuits. You learn more advanced theory and techniques, and do work like that of a professional radio technician. These circuits operate on your regular AC or DC house current.

**THE KIT FOR EVERYONE**

You do not need the slightest background in radio or science. The "Edu-Kit" is used by young and old, schools and colleges, Armed Forces Personnel and Veterans Administration for training and rehabilitation. One of the most important aspects of the "Edu-Kit" is the Consultation Service which we provide. We welcome students to send us their problems, whether related to any of the material covered in the "Edu-Kit" course, or encountered in other experiences in the field of electronics.

**THE "EDU-KIT" IS COMPLETE**

You will receive all parts and instructions necessary to build several different radio and electronic circuits, each guaranteed to operate. Our kits contain tubes, tube sockets, variable, electrolytic, mica, ceramic and paper dielectric condensers, resistors, tie strips, coils, hardware, tubing, punched metal chassis, Instruction Manuals, hook-up wire, solder, selenium rectifiers, volume controls, switches, etc. In addition, you receive Printed Circuit materials, including Printed Circuit Chassis, special tube sockets, hardware and instructions. You also receive a useful set of tools, pliers, cutters, an alignment tool, professional electric soldering iron, wrench set, and self-powered, dynamic Radio and Electronics Tester. The "Edu-Kit" also includes Code Instructions and the Progressive Code Oscillator. You will also receive lessons for servicing with the Progressive Signal Tracer and the Progressive Signal Injector, a High Fidelity Guide, FCC Amateur License Training Book, and a Quiz Book.

**TROUBLE-SHOOTING LESSONS**

You will learn to trouble-shoot and service radios, using the professional Signal Tracer, the unique Signal Injector, and the dynamic Radio and Electronics Tester. Our Consultation Service will help you with any technical problems.

J. Stasalis, 25 Poplar St. Waterbury, Conn., writes: "I have repaired several sets for my friends. I made money. The "Edu-Kit" paid for itself. I was ready to spend \$240 for a course, but I found your ad and sent for your kit."

**FREE EXTRAS**

- Set of Tools • Radio Book • Radio and Electronics Tester • Electric Soldering Iron • Pliers-Cutters
- Alignment Tool • Tester Instruction Book • Hi-Fi Book • Book • Quiz Book • Membership in Radio-TV Club; Consultation Service • FCC Amateur License Training • Printed Circuitry • Certificate of Merit • Valuable Discount Card • Wrench Set

- Choose From These Popular "Edu-Kit" Models
- 10A: 10 Circuits \$14.95
  - 15A: 15 Circuits \$19.95
  - 16A: 16 Circuits (includes Printed Circuitry) \$22.95
  - 20A: 20 Circuits (includes Printed Circuitry and 4 Advanced Circuits) \$28.95
  - 25A: 25 Circuits (includes Printed Circuitry and 9 Advanced Circuits) \$30.95

**UNCONDITIONAL MONEY-BACK GUARANTEE**

Please RUSH my Progressive Radio "Edu-Kit" to me. BE SURE TO INCLUDE all the FREE EXTRAS and BONUS RESISTOR and CONDENSER KITS WORTH \$7.00.

- MODEL desired ..... Price
- Send "Edu-Kit" postpaid. I enclose remittance in full.
  - Send "Edu-Kit" C.O.D. I will pay postage.
  - Send me FREE additional information describing "Edu-Kits."

Name.....  
 Address.....  
**Progressive "EDU-KITS" Inc.**  
 1186 Broadway Dept. 198Q Hewlett, N.Y.

Allied Radio	19
Arrow Fastener Company, Inc.	41
Atlas Sound Div., American Trading and Production Corp.	18
Audio Unlimited Inc.	107
Audion	83
B & K Manufacturing Co.	81, 95
Batty Electronics Corp.	101
Bell Telephone Labs.	16
Blonder-Tongue Labs.	73
Bogen-Preto Div. of The Slinger Corp.	67
Brooks Radio & TV Corp.	94
Capitol Radio Engineering Institute	15
Carston	106
Castle TV Tuner Service	101
Centralab, Div. of Globe-Union	22
CLASSIFIED ADS	104-105
Cleveland Institute of Electronics	95
Colordaptor	95
Coyne Electrical School	101
Danpp-Chaser, Inc.	83
DeLoe Div. of General Motors	75
DeVry Technical Institute	7
Dressner	83
Electro-Voice Inc.	8-9
Electronic Chemical Corp.	63
Electronic Instrument Co. (EICO)	30
Electronic Measurement Corp. (EMC)	97
Electronic Publishing Co. Inc.	107
Empire Scientific Corp.	3
Fairchild	78
GM Photoelectronics	106
Gen-hack Library Inc.	91, 96, 100
Gratham School of Electronics	17
Hallcrafters	29
Heald's Engineering College	39
Heath Company	71
Holt, Rinehart & Winston Inc.	98, 106
Indiana Technical College	106
International Crystal Mfg. Co. Inc.	89
Johnson Co. (E. E.)	80
Key Electronics Co.	99
Lafayette Radio	69
Mallory Co. Inc. (P. R.)	23
McMure Co. (H.)	101
Moss Electronics Inc.	86
Multicare Sales Corp. Div. of British Industries	99
Name tape	83
National Radio Institute	27-28, 95, 107
National Technical Schools	5
North American Philips Co. Inc. (Norelco)	12
Nortronics Co.	83
Phileo Corp. (Accessory Div.)	58-59
Progressive Edu-Kits Inc.	106
R-Columbia Products Co. Inc.	78
R. A. E. Equipment, Inc.	93
RCA (Electron Tube Div.)	Back Cover
RCA Institutes	64-65
Rad-Tel Tube Co.	108
R T S (Electronics Div.)	13
Roseberry & Son, Inc. (H. A.)	83
Sams & Co. Inc. (Howard W.)	25, 102
Saxitone Tape Sales (Div. of Commissioned Electronics Co., Inc.)	107
Schober Organ Co., Inc.	87
Scientific Development Corp.	96
Secore	77, 79
Smear Radio Corp.	63
Sonotone Corp.	14
Sprague	20
Standard Kollman Industries Inc.	3rd Cover
Superscope, Inc.	24
Switchcraft Inc.	101
T A B	107
Tarzian (Sarkis) Inc. (Tape Div.)	10
Teraco Corp.	62
Transvision	73
Triplet Electrical Instrument Co.	2nd Cover
Tunk-Sol Electric Inc.	92
Turner Microplate Co.	21
Twirl-On Tools	98
Vaco	85
Winegard Co.	26

**SCHOOL DIRECTORY PAGE 103**

- Niles Bryant School
  - Indiana Technical College
  - International Correspondence School
  - Milwaukee School of Engineering
  - Northrop Institute of Technology
  - Pacific International College of Arts & Sciences
  - Phila. Wireless Technical Institute
  - Tri-State College
  - Valparaiso Technical Institute
- Printed in USA

**ENGINEERING DEGREE IN SCIENCE MATH**  
 27 or 36 MOS.  
 U.S. degree—36 mos. • B.S.E. degree—27 mos.

Accelerated year-round program prepares for early employment in fields of Science and Engineering. Regular 4-year Program for B.S. Degree completed in 36 months, special engineering degree program in 27. Classes start June, July, September, January, March. Quality education. Graduates employed from coast to coast, Government approved for veteran training. Students from 50 states, 40 countries. 20 buildings; dorms; gym, Campus. Save time and money. Earn board. Write for catalog, 1762 E. Washington Boulevard, Fort Wayne 2, Indiana

**INDIANA TECHNICAL COLLEGE**

**FM TUNER**

5 TUBES + DIODE & RECTIFIER **\$16.95**  
 2 For \$29.95

WITH AMPLIFIER & SPEAKER BUILT IN. USE AS A TUNER OR RADIO, VERNIER TUNING. 88 TO 108 MC. FREE CATALOG.

**GM PHOTOELECTRONICS**  
 623 South Gay Street KNOXVILLE, TENNESSEE

**HI-FI RECORDING TAPE**  
 Splice Free (except 2400') Freq. Resp.: 20, 20,000 cps. 15 day money-back guarantee

1200' 7" Acetate	\$1.29	\$1.17	99¢
1800' 7" Acetate	1.79	1.59	1.45
1800' 7" Mylar	1.99	1.95	1.85
2400' 7" Mylar	2.69	2.59	2.49
2400' 7" tensilized mylar	2.99	2.95	2.90

Can Be Assorted. Add 15¢ Postage Per Reel 10¢ for 24-Lot Orders

**HI-FI COMPONENTS, TAPE RECORDERS**  
 At wholesale prices shipped within 24-48 hours. We'll email low quotes on your packaged Hi-Fi inquiries. Send for free wholesale catalogue.

125-RD East 88 St., New York 28, N. Y.  
**CARSTON Studios**

**DON'T THROW OLD RADIOS AWAY!**

Here's the data you need to fix them FAST...and good as new!

Just look up the how-to-do-it data on that old radio you want to fix!  
 Four times out of 5, this giant, 3 1/2-pound, 744-page Ghirardi RADIO TROUBLESHOOTER'S HANDBOOK gives exactly the information you need to fix it in a jiffy. Tells what is likely to be raising the trouble... shows how to fix it. No useless testing. No wasted time. Handbook covers practically every radio receiver model made by 202 manufacturers between 1925 and 1942. Using it, even beginners can easily fix old sets which might otherwise be thrown away because service information is lacking. With a few simple repairs most of these old sets can be made to operate perfectly for years to come.

**THE ONLY GUIDE OF ITS KIND**  
 Cuts service time in half!

Includes rare common trouble symptoms and their remedies for over 4,800 models of old home, auto radios and record changers; Arlino, Apex, Arvin, Atwater, Kent, Belmont, Bosch, Brunswick, Clarion, Crosley, Emerson, Fada, G.E., Kolter, Majestic, Motorola, Philco, Pilot, RCA, Silvertone, Sparton, Stromberg and dozens more. Includes hundreds of pages of invaluable tube and component data, service short cuts, etc.

**TRY IT 10 DAYS . . . see for yourself!**

Department RE-62 623900  
**HOLT, RINEHART & WINSTON, INC.**  
 P.O. Box 2334, Grand Central Station  
 New York 17, New York  
 Send Ghirardi's RADIO TROUBLESHOOTER'S HANDBOOK (#70007) for 10-day free examination. If I decide to keep book, I will remit the full price of only \$10 plus postage. Otherwise, I will return book postpaid and owe you nothing. (SAVE! Send \$10 with order and we pay postage. Same return privilege with money refunded.)  
 NAME.....  
 ADDRESS.....  
 CITY, ZONE, STATE.....  
 OUTSIDE U.S.A.—Price \$10.50 cash with order only. Above offer expires February 28, 1963

bridge requiring at least three fixed resistors and a zero-set potentiometer. Because these circuits employed a germanium transistor, temperature drift necessitated frequent resetting of zero. The diagram shows a minimum-component circuit which overcomes the old disadvantages.

A 2N333 silicon transistor is used. This unit costs \$6.50 but offers enough advantages to justify the investment. For example, no zero drift can be seen on the 0-1 dc milliammeter, so no zero-set circuit is needed; no deflection drift can be seen on the meter and, since the no-signal collector current is so tiny (nominal value of .002 microampere), no ON-OFF switch is

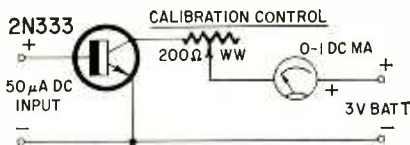

needed—the battery will last for its full shelf life.

A 50 µa dc input will deflect the 1-ma meter to full scale (10 µa will deflect a 100-µa 2,000-ohm meter to full scale). Response is linear. The 200-ohm CALIBRATION CONTROL adjusts for full-scale deflection with an accurately known dc input. This control may be enclosed inside the instrument case and provided with a slotted shaft for screw-driver adjustment, since it seldom needs adjustment and then only when the calibration is checked periodically.—*Ted Ladd*

## SOLAR BATTERY POWERS TUNNEL DIODES

A silicon solar battery, operated from either sunlight or artificial illumination, will supply enough dc power to operate tuner-diode oscillators and short-distance transmitters. However, some experimenters have had trouble because of the internal resistance of the cell under varying operating conditions. The secret is to provide the cell with a constant, low-resistance output (lower than that of the tunnel diode).

Here is a practical solar battery circuit. The light-sensitive unit is a five-module silicon photocell (International Rectifier type SM5-1020E6BPL,

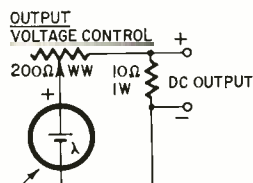

or equivalent). (This sun battery may be considered expensive but it is well worth the cost in this application.) The 10-ohm resistor provides the dc source with the low-impedance output needed for proper operation of the tunnel diode. The 200-ohm pot permits smooth adjustment of the output voltage. The maximum dc voltage is 1.25 in bright sunlight, or 0.5 when a 100-watt incandescent lamp is placed 1 foot from the cell.—*Rufus P. Turner* END

## "TAB" TUBES

Six Months Guarantee! No Rejects!  
New & Used Gov't & Mfrs. Surplus!

Orders \$10 or more. Receiving types only ppd, 48 states

0A2	.80	6B7	.69	12A7	.59	18S1	1.00
0B2	.95	6BK7	.99	12AT7	.84	117Z	1.10
0C3	.55	6E7	1.25	12BE6	.94	4-65A	18.00
0C4	.69	6EN6	.98	12AU7	.69	2D21	2/S1
0Z4	.59	6BQ6	1.19	12AX7	.79	3D23	3.85
1B3	.78	6BZ7	1.25	12BA6	.65	717A	3/S1
1R5	.78	6CS	.69	12BD6	.59	4-25	2/S1
1S4	.78	6CB6	.80	12BE8	.59	4-25	35.00
1T4	.78	6GD6	1.49	12BE8	.59	4P60	20.00

Send for Catalog

1U5	.73	6H6	5/S1	12BH7	.99	4X250	35.00
1X2A	1.99	6J5	.52	12BY7	.98	4X500	38.00
3Q5	.86	6J6	.48	12BY7	.98	5BP4	Query
3V4	.68	6K6	.59	12C06	1.45	5BP4	4.00
3V4	.68	6L6	1.19	12SA7	.94	100T	7.00
5R4	.98	6S4	.59	12SH7	.79	316A	5/S1
5U4	99¢	6SA7	.89	12SJ7	.75	388A	3/S1
5V4	.89	6SB7	1.19	12SQ7	.84	416B	4.00

Wanted Test Equipment from schools & U  
6AC7 .59 6SC7 .89 198G6 2.15 450T 42.00  
6AG7 .89 6S7 .79 250G6 1.99 80T 1.00  
6AK5 .89 6S7 .69 25L6 .69 866A 1.89  
6AK5 2/S1 6S7 .72 25W4 .77 811 4.40  
6AG5 .63 6SL7 .89 25Z5 .63 814 3.45  
6AS7 3.00 6SN7 2/S1 25Z6 .75 815 2.75  
6AT6 .69 6SB7 .98 35L6 .69 829B 8.00

6AU4	1.10	6UB	.98	35W4	.49	832A	7.00
6AU5	1.19	6VGT	.70	35Z5	.69	872A	3.50
6AU5	.89	6V4	.79	50A5	.69	1625	2/S1
6AX4	.79	6W6	.69	50A5	.69	8146	4.00
6BE6	.59	6X4	2/S1	50B5	.69	5879	2/S1
6BE6	.59	6X5	.49	50C5	.69	5881	2.70
6BG6	1.50	6Y5	.97	50L6	.69	6550	3.00
6BH6	1.72	6N7	.89	80	.59	5854	1.00

TUBES WANTED! WE BUY! SELL & TRADE!

GTD! Octal Silicon—5U4G—Tube Replacement  
1120Rms 1600Piv \$4 @ 2 for \$8; 4 for \$10  
5R4 Silicon 1900/2800Piv \$4  
866A Silicon 5000/10400Piv \$9

## "TAB" SILICON 750MA \* DIODES

NEWEST TYPE! LOW LEAKAGE  
D.C. or Battery. Derate 20%

rms/piv	rms/piv	rms/piv	rms/piv	DC
35/50	70/100	140/200	210/300	&
.07	.14	.19	.29	L
280/400	350/500	420/600	490/700	O
.34	.44	.53	.69	A
rms/piv	rms/piv	rms/piv	rms/piv	D
560/800	630/900	700/1000	770/1100	
1.98				

Diode order \$10 shipped Post free

Low Priced T300 Silicon Diodes  
Rated 400piv/280rms at 300Ma @ 100°C  
.25 each; 30 for \$7; 100 for \$20; 500 for \$90

## "TAB" FOR TRANSISTORS & DIODES!!!!

Full Length Leads U.S.A. Mfg.

Factory Tested & GTD!  
PNP Hi Power 15 Amp. TO3 & TO36 Pkg.  
2N441, 2N277 \$1.25 @ 10 for \$11  
2N442, 2N278 \$3 @ 2N443, 2N175, 5A  
2N677 \$1 @ 2N677A \$2 @ 2N677B  
53 @ 2N677C \$5 @  
3 Amp. 2N155, 2N156, 2N255, 2N256,  
2N107, 2N524, TO36P, 49 for \$5.  
PNP 2N123, 2N107, CK722 5 for \$1; PNP 2N292,  
293; PNP 2N223 \$3 @ 12 for \$9, 100 for \$65;  
PNP 2N670/300MW \$5 @ 10 for \$4  
PP 2N671/1 Watt \$7 @ 10 for \$6.  
Round or Diamond Base Mica Mid Kit \$30 @ 1.  
Power Heat Sink Fins \$0.59 @ 50.  
Kit Glass Diodes equiv. 1N34A, 4E, 48, 51,  
12 for \$1, 100 for \$6, 1000 for \$50

KIT ZENER DIODES up to 400MW SINGLE &  
DOUBLE ENDED ZENER DIODES 2for\$1

TRANSISTOR POWER CONVERTER  
12VDC to 500VDC up to 200MA  
100 Watts Tap at 250VDC  
DB50 \$33  
12VDC to 250VDC up to 150MA  
Type C1225E \$30

PC200 POWER 200 WATT AC CONVERTER 12VDC  
Input, AC-117V/60 cys. \$32.

PNP TRANSISTORS MIXER \* OSCILLATOR  
\* CONVERTER Equal to CK760, CK766, 2852,  
2N112, 114, 135, 136, 137, 140, 219, 411, 412,  
414, 415 & Others. Special 49¢ @ 5 for \$2, 100 for  
\$35. If Amplifier 2853, GT760, 2N111, 112A, 139,  
218, 409, 410, 413, 414, 416 & Others. SPECIAL  
49¢ @ 5 for \$2, 100 for \$35.

D.C. POWER SUPPLY 115V/60to800Cys. Inpt.  
330&165VDC Up to 150MA. CASED! SPECIAL \$5

SILICON POWER DIODE STUDS\*  
Operation Up to 125°C Case Temp.

D.C. Amps	50Piv 35Rms	100Piv 70Rms	150Piv 105Rms	200Piv 140Rms
2	.23	.34	.42	.49
3	.90	1.15	1.10	1.25
7	.70	.95	1.15	1.40
12	.85	1.15	1.35	1.60
35	1.80	2.20	2.95	3.25
70	3.75	4.50	5.00	5.60
240	4.50	5.40	7.70	9.00
D.C. Amps	300Piv 210Rms	400Piv 280 Rms	500Piv 350Rms	600Piv 420Rms
2	.60	1.50	1.50	1.95
3	1.50	1.80	2.10	2.65
6	1.65	1.95	2.70	3.20
12	1.85	2.07	Query	Query
35	4.90	6.10	Query	Query
70	8.80	Query	Query	Query
240	Query	Query	Query	Query

\*Derate 20% for Battery or Capacitive Load or  
D.C. Blocking! \*Stud mounted on Heat-sink.

TWO 866A's and FILAMENT \$6  
XFMR 10 Kv Instd SPECIAL!

TERMS: Money Back Guarantee!  
Our 18th year. \$2 min. order  
F.O.B. N.Y.C. Add shps charges  
or for C.O.D. 25% Dep. Prices  
shown subject to change.  
111-GF Liberty St., N.Y. 6, N.Y.

Send 25¢ for Catalog  
PHONE: RECTOR 2-6245

Save 30% on 4-track Stereo Music on Tape!  
Empty 3 in. plastic reels 7¢ ea.  
BARGAIN PRICES!  
SEND FOR OUR FREE  
Tape Recorder/Blank/Pre-recorded Tape Catalog  
SAXITONE TAPE SALES  
(Div. of Commissioned Electronics Co., Inc.)  
1776 Columbia Road Washington, D.C.

**AUDIO unlimited**  
Specializes in SAVING YOU MONEY  
✓ FACTORY FRESH COMPONENTS  
✓ LOWEST POSSIBLE QUOTATIONS  
✓ FAST DELIVERY  
We are FRANCHISED DEALERS for most Hi-Fi lines. Most orders SHIPPED PROMPTLY from stock. RECORDING TAPE at LOWEST PRICES. FREE 95 page STEREO CATALOG  
190-R Lex. Ave., Cor. 32 St., New York 16, N. Y. Visit Our Showroom

TRAIN WITH THE LEADER  
**NRI**  
FOR YOUR FCC LICENSE  
Prepare for your First Class FCC License through NRI's special and up-to-date FCC home-study course. Qualify for better paying jobs and growing opportunities open to you with your FCC "Ticket." Tear out ad, write your name and address in margin and mail to NRI for complete facts.  
NATIONAL RADIO INSTITUTE  
Washington 16, D.C. BFF  
Accredited Member National Home Study Council

to SERVICE CHARGES and RECORD KEEPING  
the business-like approach

For customer's prices on every replacement part, plus flat rate and hourly service charge data, regional and national. Dave Rice's OFFICIAL PRICING DIGEST, listing over 63,000 items. \$2.50.  
▲ AVAILABLE FROM YOUR DISTRIBUTOR ▼

If you want to operate on a professional level, Dave Rice's OFFICIAL ORDER BOOKS give you triplicate forms for order, invoice, and office records... spaces for tubes, parts, serial numbers, labor and tax charges, signatures, etc. 75¢ per book, \$6.50 for dust-proof box of 10.  
**Dave Rice's**  
ELECTRONIC PUBLISHING COMPANY, INC.  
133 N. Jefferson St. • Chicago 6, Ill.

# RAD-TEL

LEADING "DIRECT-BY-MAIL" TUBE CO.

UP TO **75% OFF**

**RAD-TEL'S QUALITY  
BRAND NEW TUBES  
1-YEAR GUARANTEE • 1-DAY SERVICE  
OVER 500 TYPES IN STOCK**



THE SIGN OF  
RAD-TEL'S  
RELIABILITY

\*Manufacturers Suggested List Price

**FREE!**

Send For New Tube  
& Parts Catalog

Send For Trouble  
Shooting Guide

## PUBLIC ADDRESS SYSTEM—50% OFF\*

- WITH PLUG-IN CRYSTAL MIKE
  - A MUSICAL INSTRUMENT AMPLIFIER
- P.A. SYSTEM IS EXCELLENT FOR MEETINGS, SPEECHES, SCHOOLS, GROUPS, etc.

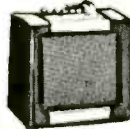

MADE IN U.S.A.  
Latest deluxe model has a specially designed heavy 8" speaker combined with 2 dual purpose tubes (equal to a 6 tube amp.) and output transformer to develop fine response in a 4-tube, 5 watt amplifier. Inputs for 2 instruments; 4 controls: volume, tone, tremelo speed & depth; on/off switch; fuse; all are mounted on top. New acoustically designed cabinets, covered with gray simulated leather, with woven acoustical grille cloth. Complete with crystal microphone ready to operate as public address system. Fully guaranteed against defects in parts and workmanship. Shipping weight 13 lbs. Size 15½" x 13" x 6". Priced at ROCK-BOTTOM! List \$79.00\*.

NO. A5 ..... \$39.50



**RAD-TEL TUBE CO.**

Dept. RE-6 55 CHAMBERS ST., NEWARK 5, NEW JERSEY

TERMS: 25% deposit must accompany all orders, balance COD. Orders under \$5: add \$1 handling charge plus postage. Orders over \$5: plus postage. Approx. 8 tubes per 1 lb. Subject to prior sale. No COD's outside continental USA.

### EACH TUBE INDIVIDUALLY & ATTRACTIVELY BOXED & BRANDED RAD-TEL

Qty.	Type	Price	Qty.	Type	Price	Qty.	Type	Price	Qty.	Type	Price
—	0Z4	.79	—	6AU4	.82	—	6J6	.67	—	12CX6	.54
—	1AX2	.62	—	6AU6	.52	—	6K6	.63	—	12D4*	.69
—	1B3	.79	—	6AU7	.61	—	6L6	1.06	—	12DB5	.69
—	1DN5	.55	—	6AU8	.87	—	6N7	.98	—	12DE8	.75
—	1G3*	.79	—	6AV6	.41	—	6S4	.51	—	12DL8	.85
—	1J3*	.79	—	6AW8	.90	—	6SA7GT	.76	—	12DQ6	1.04
—	1K3*	.79	—	6AX4	.66	—	6SG7GT	.41	—	12DS7	.79
—	1R5	.62	—	6AX5	.74	—	6SH7GT	.49	—	12DT5*	.76
—	1S4	.59	—	6AX7	.64	—	6SJ7	.88	—	12DT7*	.79
—	1S5	.51	—	6AX8*	.92	—	6SK7GT	.74	—	12DT8*	.79
—	1T4	.58	—	6BA6	.50	—	6SL7GT	.80	—	12DU7	1.01
—	1U4	.57	—	6BA8	.88	—	6SN7GT	.65	—	12DW8*	.89
—	1U5	.50	—	6BC5	.61	—	6SQ7	.73	—	12DZ6	.56
—	1X2B	.82	—	6BC7	.94	—	6T4	.99	—	12ED5	.69
—	2AF4	.96	—	6BC8	.97	—	6T8	.85	—	12EG6	.54
—	2BN4	.64	—	6BD5	1.25	—	6U8	.83	—	12EK6	.56
—	2EN5*	.45	—	6BE6	.55	—	6VG6T	.54	—	12EL6	.50
—	3AL5	.42	—	6BF5	.90	—	6W4	.60	—	12EM6	.79
—	3AU6	.51	—	6BF6	.44	—	6W6	.71	—	12EN6	.78
—	3AV6	.41	—	6BG6	1.66	—	6X4	.39	—	12EZ6	.53
—	3BA6	.51	—	6BH6	.65	—	6X5GT	.53	—	12F8	.66
—	3BC5	.54	—	6BH8	.87	—	6X8	.80	—	12FA6	.79
—	3BE6	.52	—	6BJ6	.62	—	7A8	.68	—	12FM6	.43
—	3BN6	.76	—	6BJ7	.79	—	7AU7	.61	—	12FR8	.91
—	3BU8	.78	—	6BK7	.85	—	7B6	.69	—	12FX8	.85
—	3BY6	.55	—	6BL7	1.00	—	7EY8*	.73	—	12GC6	1.06
—	3BZ6	.55	—	6BN4	.57	—	7F8	.90	—	12J8	.84
—	3CB6	.54	—	6BN6	.74	—	7N7	.90	—	12K5	.65
—	3CS6	.52	—	6BQ6	1.05	—	7S7	1.01	—	12L6	.58
—	3DG4*	.85	—	6BQ7	1.00	—	7Y4	.69	—	12SA7	.92
—	3DK6*	.60	—	6BS8	.90	—	8AU8	.83	—	12SF7	.69
—	3DT6	.50	—	6BU8	.70	—	8AW8	.93	—	12SH7	.49
—	3Q4	.63	—	6BX7	1.02	—	8BQ5	.60	—	12SJ7	.67
—	3Q5	.80	—	6BY5	1.15	—	8CG7	.62	—	12SK7	.74

### RAD-TEL TUBE CO. NOT AFFILIATED WITH ANY OTHER MAIL ORDER TUBE COMPANY

—	3S4	.61	—	6BY6	.54	—	8CM7	.68	—	12SL7	.80
—	3V4	.58	—	6BY8	.66	—	8CN7	.97	—	12SN7	.67
—	4BQ7	1.01	—	6BZ6	.55	—	8CS7	.74	—	12SQ7	.78
—	4BZ7	.96	—	6BZ7	1.01	—	8CX8	.93	—	12U7	.62
—	4BZ8	1.10	—	6BZ8	1.09	—	8EB8	.94	—	12V6	.53
—	4CS6	.61	—	6C4	.43	—	8SN7	.66	—	12W6	.69
—	4DT6	.55	—	6CB6	.55	—	9CL8	.79	—	12X4	.38
—	5AM8	.79	—	6CD6	1.42	—	11CY7	.75	—	17AX4	.67
—	5AN8	.86	—	6CE5*	.57	—	12A4	.60	—	17BQ6	1.09
—	5AQ5	.52	—	6CF6	.64	—	12AB5	.55	—	17DQ6	1.06
—	5AS8*	.86	—	6CG7	.61	—	12AC6	.49	—	17W6	.70
—	5AT8	.80	—	6CG8	.77	—	12AD6	.57	—	18FW6*	.49
—	5AV8	1.01	—	6CK4*	.70	—	12AE6	.43	—	18FY6*	.50
—	5BC8	.79	—	6CL8	.79	—	12AE7	.94	—	18FX6*	.53
—	5BE8	.83	—	6CM6	.64	—	12AF3	.73	—	19AU4	.83
—	5BK7	.82	—	6CM7	.66	—	12AF6	.49	—	19BG6	1.39
—	5BQ7	.97	—	6CM8*	.90	—	12AJ6	.46	—	19C8	1.14
—	5BR8	.79	—	6CN7	.65	—	12AL5	.45	—	19T8	.80
—	5BT8*	.83	—	6CQ8	.84	—	12AL8	.95	—	21EX6	1.49
—	5CG8	.76	—	6CR6	.51	—	12AQ5	.60	—	25AV5	.83
—	5CL8	.76	—	6CS6	.57	—	12AT6	.43	—	25AX4	.70
—	5CM8*	.90	—	6CS7	.69	—	12AT7	.76	—	25BK5	.91
—	5CQ8	.84	—	6CU5	.58	—	12AU6	.51	—	25BQ6	1.11
—	5CZ5*	.72	—	6CU6	1.08	—	12AU7	.60	—	25C5	.53
—	5EA8	.80	—	6CY5*	.70	—	12AV6	.41	—	25CA5	.59
—	5EU8	.80	—	6CY7	.71	—	12AV7	.75	—	25CD6	1.44
—	5J6	.68	—	6DA4*	.68	—	12AX4	.67	—	25CQ6	1.11
—	5T8	.81	—	6DB5	.69	—	12AX7	.63	—	25DN6	1.42
—	5U4	.60	—	6DB6	.51	—	12AY7	1.44	—	25EH5	.55
—	5U8	.81	—	6DE6	.58	—	12AZ7	.86	—	25L6	.57
—	5V3	.90	—	6DG6	.59	—	12B4	.63	—	25W4	.68
—	5V6	.56	—	6DK6	.59	—	12BA7	.84	—	32ET5	.55
—	5X8	.78	—	6DN6	1.55	—	12BD6	.50	—	32L7	.90
—	5Y3	.46	—	6DQ6	1.10	—	12BE6	.53	—	35B5	.60
—	6A8G	1.20	—	6DT6	.53	—	12BF6	.44	—	35C5	.51
—	6AB4	.46	—	6DT8*	.79	—	12BH7	.77	—	35L6	.57
—	6AC7	.96	—	6E8	.79	—	12BK5	1.00	—	35W4	.42
—	6AF3	.73	—	6EB5*	.72	—	12BL6	.56	—	35Z5	.60
—	6AF4	.97	—	6EB8	.94	—	12BQ6	1.06	—	36AM3*	.36
—	6AG5	.68	—	6EM5*	.76	—	12BR7	.74	—	50B5	.60
—	6AH4	.81	—	6EM7	.82	—	12BV7	.78	—	50C5	.53
—	6AH6	.99	—	6EU8	.79	—	12BY7	.77	—	50EH5	.55
—	6AK5	.95	—	6EW6	.57	—	12BZ7	.75	—	50L6	.61
—	6AL5	.47	—	6EY6*	.75	—	12C5	.56	—	70L7	.97
—	6AM8	.78	—	6F5GT	.39	—	12CN5	.56	—	70Z5	.69
—	6AQ5	.53	—	6FE8	.75	—	12CR6	.54	—	807	.70
—	6AR5	.55	—	6GH8	.80	—	12CU5	.58	—	117Z3	.61
—	6AS5	.60	—	6GK6*	.79	—	12CU6	1.06	—		
—	6AS6	.80	—	6GN8*	.94	—			—		
—	6AT6	.43	—	6H6	.58	—			—		
—	6AT8	.79	—	6J5GT	.51	—			—		

New Tube Types Offered by Rad-Tel\*



**FINALLY!**

# **A SUPERIOR LIQUID CONTACT CLEANER**

**Ultra-New *CONTACARE KIT II***



**\$1<sup>25</sup>**

**Cleans Almost Instantly with Minimum Rubbing**

After years of painstaking research, Standard Kollsman for the first time can honestly recommend a liquid contact cleaner. You'll find it in the new Contacare Kit II. You'll also find a soft tough cloth—lint-free to avoid fouling . . . and a tube of non-evaporating grease for permanent channel lubrication and contact protection. Instruction sheet is clear, brief, and complete. Kit is compact and sturdy. Try it soon . . . and save your elbow grease for jobs that need it.

- NO RESIDUE
- NO SUBSEQUENT CORROSION
- NON-FLAMMABLE
- NON-CONDUCTIVE

*INSIST ON THE GENUINE CONTACARE KIT II*

**standard kollsman<sup>®</sup> INDUSTRIES, INC.**

FORMERLY STANDARD COIL PRODUCTS CO., INC., MELROSE PARK, ILLINOIS

**WORLD'S LARGEST MANUFACTURER OF TELEVISION TUNERS**

# NOW! Only 4 Picture Tubes can fill 50% of your replacement needs\*



## RCA 21CBP4A, 21AMP4A, 21ZP4B and 21YP4A Universal Silverama® Picture Tubes Replace 33 Industry Types

Now, four—*only four* RCA Universal Silverama types can take care of *half* your picture tube replacements. Think of what this means to you in terms of simplicity, economy and efficiency:

- **Fewer trips to the distributor.**  
You can keep these four types in your shop, knowing that you will quickly have use for them.
- **Faster service.**  
For half your picture tube replacements, you have the right tube on hand, in the shop. Saves hours of time picking up the proper tube or waiting for it to be delivered. The time saved gives you a competitive edge!
- **Picture tube replacements from your service truck.**  
It's simple to carry one of each of these Universal types on your service truck so you can make half of your picture tube replacements *right on the spot*.
- **Fewer types to take care of.**  
Think of the headaches and extra bookkeeping this simplification saves.

These four types are part of a growing family of RCA Universal Picture Tubes designed to help you fill the maximum number of sockets with the minimum number of types.

RCA Universal Silverama Picture Tube types are made with an all-new electron gun, the finest parts and materials and a high-quality envelope that has been thoroughly inspected, cleaned and rescreened prior to reuse.

Start now to simplify your picture tube replacement problems. See your authorized RCA Distributor this week about RCA Universal Silverama Picture Tubes.

\*Based on EIA figures for the national movement of the picture tube types below.

RCA Silverama "Universal" Type	Replacing		
21CBP4A	21ALP4	21ANP4A	21CBP4B
	21ALP4A	21BTP4	
	21ALP4B	21CBP4	21CMP4
	21ANP4	21CBP4A	
	21ATP4	21BAP4	21CWP4
	21ATP4A	21BNP4	21DNP4
21AMP4A	21ATP4B	21CVP4	21FLP4
	21ACP4	21AMP4A	21BSP4
	21ACP4A	21AQP4	
21ZP4B	21AMP4	21AQP4A	21CUP4
	21ZP4	21ZP4A	21ZP4B
21YP4A	21YP4	21YP4A	21AFP4

RCA Electron Tube Division, Harrison, N. J.



The Most Trusted Name in Electronics